



MAGNUM GETTING STARTED
CHILLER MANUAL REV 1.0
MAGNUM HARDWARE REV 6.1

The MCS Commitment

Our commitment is to provide practical solutions for the industries needs and to be both a leader and partner in the effective use of microprocessor controls.

Micro Control Systems, Inc.
5877 Enterprise Parkway
Fort Myers, Florida 33905
Ph: (239) 694-0089
FAX: (239) 694-0031
www.mcscontrols.com

Information contained in this manual has been prepared by Micro Control Systems, Inc. and is company confidential and copyright © protected 1996. Copying or distributing this document is prohibited.

Revision Page

Date	Author	Description of Changes
07/08/08	John G. Walterick	Created manual

Table of Contents

Revision Page	2
Table of Contents	3
Introduction	4
Introduction to Magnum CHL V8 Software Family	4
Common support items of the CHL V8 Software Family:	4
About Magnum Hardware Support by CHL V8 Software Family	4
About this Manual.....	4
About the Magnum.....	5
About PC Support Software for MAGNUM.....	5
MCS 485 Network.....	5
MCS Ethernet Port.....	6
MCS 485 Communications	7
MCS 485 Network with Local RS232 Communications.....	7
MCS 485 Network with Remote Modem Communications.....	8
Keypad / Display Functions	9
Passwords	9
Setpoints	9
Lockout Reset	10
Status Display – Chiller (Default at Power Up)	11
Status Display – Circuit (x)	11
By pressing the PG↑ you will go back to the previous display or PG↓ you will get information on the next circuit. After all circuit information is displayed pressing the PG↓ will return the user to the chiller display. ...	11
Key Keypad Functions.....	12
Preparing for Upgrading an Existing Chiller	13
Step 1- Open MCS Supplied Upgrade Kit	13
Step 2- Plan Mounting New Micro.....	13
Step 3- How To Startup the Machine.....	14
MAGNUM Revision 6.1 & Higher	15
The MCS Sensors Quick Reference Sheet	16
Temperature & Humidity Sensors.....	16
Pressure Sensor & Digital inputs	17
Misc. Printed Circuit Boards.....	18
Trouble Shooting Quick Reference Sheet	19

Introduction

Introduction to Magnum CHL V8 Software Family

Magnum version 5 on the OS Multi Tasking operating System supports both Mechanical Expansion Valves or Electronic Expansion Valve on all Semi-hermetic screw compressors.

- Hanbell
- Hartford
- Hitachi
- Century
- Bitzer
- JE Hall
- RefCom
- etc.),

Common support items of the CHL V8 Software Family:

- Circuits (compressors) up to 8,
- Steps per Circuit up to 4,
- Relay Outputs up to 48,
- Analog Outputs up to 9,
- Sensor Inputs up to 48,
- Set points 170,
- Alarms 60

About Magnum Hardware Support by CHL V8 Software Family

The following MCS boards can be connected together via the MCS-I/O communications terminal block:

- MAGNUM with (10 RO's, 12 SI's, 4 DI's & 4 AO's
- MCS-I/O with (8 RO - 8 SI - 1 AO with I/O 7.00-C with a GAL 5.0 chip),
- MCS-RO8 (8 RO),
- MCS-SI16 (16 SI).

This provides flexibility in configuring the individual systems to obtain the desired number of points in the most economical way. The limitation is not the number of boards but the total number of points. (See above).

About this Manual

The purpose of this manual is to provide the user with an overview of the MAGNUM CHILLER MANUAL to provide the required information to upgrade & commission existing chillers in the field..

The Table of Contents will guide you through the sections but you are urged to read this entire manual. This will provide an understanding of the capabilities of the Magnum Control System and hopefully introduce other ways that you may benefit from the existing control strategies. Quick Reference sheets and MCS Specification sheets are provided in the appendixes.

This manual was created using Microsoft Office, Word 2000. A printed copy may be ordered, please refer to our Price Book. A PDF copy of this manual may be down loaded from our web site at www.mcscontrols.com. (Free of Charge)

An approved OEM of MCS may make copies and / or change any section of this manual to develop custom documentation for a site where a Magnum controller is installed. In this way, MCS supports the documentation requirements of individual customer sites.

About the Magnum

The MAGNUM is a rugged microprocessor based controller that is designed for the hostile environment of the HVAC/R industry. It is designed to provide primary control, i.e. no mechanical controls; interfacing with building management systems as well as communicate both locally and remotely. The MAGNUM provides flexibility with set points and control options that can be selected prior to commissioning a system or when the unit is live and functioning. Displays, alarms and other interfaces are accomplished in a clear and simple language that informs the user as to the status of the controller.

The MAGNUM is designed to safeguard the system that is being controlled, eliminate the need for manual intervention and to provide a simple but meaningful man-machine-interface.

About PC Support Software for MAGNUM

MCS-Config program provides the configuration file: points list, set points, options, etc., for all versions of software. This program is user friendly with English questions and drop down menus. It is written in the Microsoft Visual Basic programming language. A manual created under Microsoft Office, Word 2000, for Windows is available on our web site; www.mcscontrols.com, this is in a PDF format, on diskette or CD-ROM. The MCS-Config software is available from our web site but requires an access code. (The access code is supplied when the training class is completed.)

MCS-Connect program provides both local and remote communications to the MAGNUM independent of the type of software. Through this program, the status of the controller can be viewed and with proper authorization changes can be made to the system. Configuration files can be transmitted to or received from a MAGNUM unit. The MAGNUM automatically performs history logging; this program will complete graphing functions. A general manual created under Microsoft Office, Word 2000, for Windows is available on our web site ; www.mcscontrols.com, this is in a PDF format; on diskette or CD-ROM. The MCS-Connect software is available from our web site free of charge. (No access code is required.)

Both of these programs run under Windows 2000 or greater and they make use of the Microsoft Windows Help function to assist the user.

MCS 485 Network

The MCS 485 Network can support up to 20 MAGNUM's and their associated I/O's. Access to this network can be local, via and RS-232 connection, or remote via a 14.4K Baud modem. When using the dial up through the modem there will be no degradation in the performance of the network. The PC connected to the network must be running Windows 2000 or higher with MCS-Connect providing the actual interface program.

Each MAGNUM in the network must be assigned a unique address when the configuration file is build using the **MCS-Config** program. This address will be the key in establishing communications with the appropriate MAGNUM system. This address can be changed from the LCD / Keypad of the unit.

Notes:

- The current address of a Magnum can be viewed or changed (with Factory authorization) from the SERVICE TOOLS option on the menu display.

- RS-232 transmissions should not exceed 50' in length.
- RS-485 transmissions should not exceed 1 mile without a repeater.

MCS Ethernet Port

Communications can be through the 10/100 Mbps Ethernet communications port on the Magnum. It is necessary to use a crossover cable when connected directly to this port from a PC.

MCS 485 Communications

MCS 485 Network with Local RS232 Communications

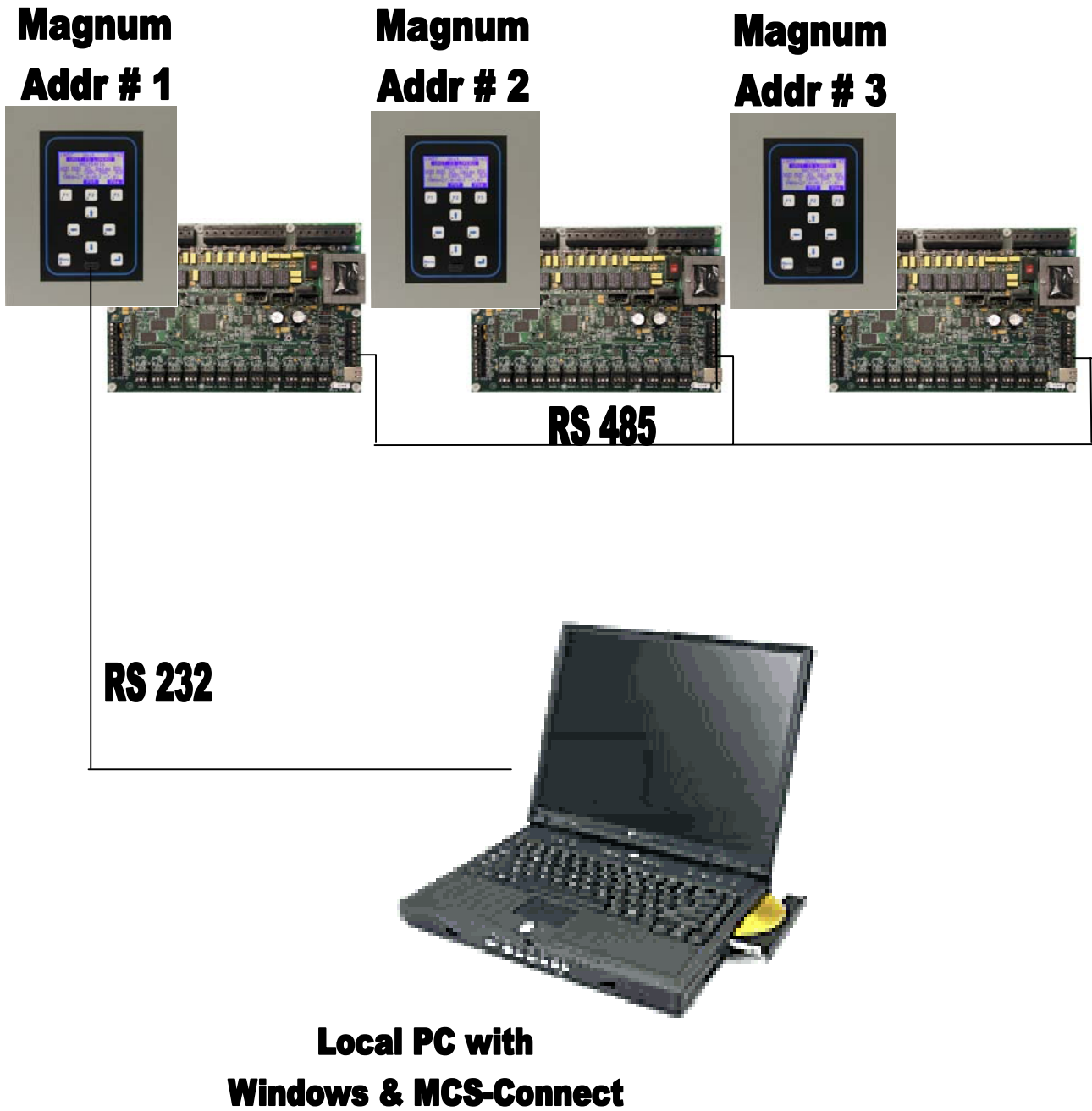

MCS 485 Network with Remote Modem Communications

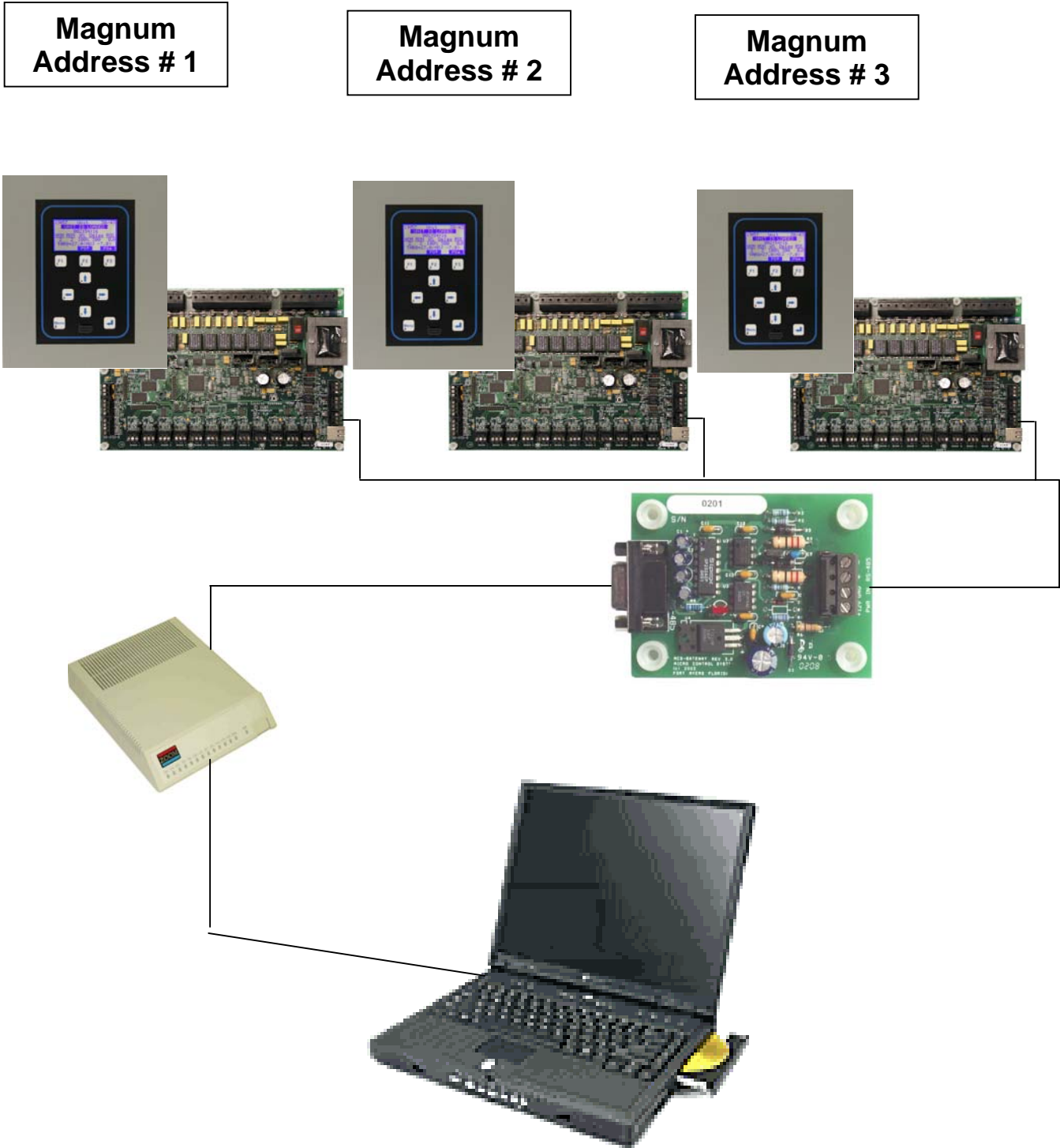

**Remote PC with
Windows & MCS-Connect**

Key Keypad Functions

The authorization code is a special four-character code that enables access in to the MCS Magnum system. The code must be numeric with values between 1 and 8. Each system can have up to 15 different authorization codes. This provides the capability of issuing different codes to different people if desired. Currently there are four levels of authorization, which provide different capabilities with in the system. The authorization code and the associated level cannot be displayed or viewed in a Magnum system. These are established when building the configuration file in the MCS-PConfig program. The authorization codes must be protected and remain confidential, if they are compromised unauthorized personnel can gain access to the system.

From the Keypad/Display the following changes can be made based upon the authorization level:

FUNCTION	VIEW	SERVICE	SUPERVI-SORY	FACTORY
Acknowledge Alarms	No	Yes	Yes	Yes
Sensor Offsets	No	Yes	Yes	Yes
Sensor Type	No	Yes	Yes	Yes
Clear Alarm History	No	No	No	Yes
Clear Point Information	No	No	No	Yes
Date & Time Set	Yes	Yes	Yes	Yes
Day of Week Set	Yes	Yes	Yes	Yes
Change No Flow Lockout or Shut Down	No	No	No	Yes
Change Rotate Yes or No	No	No	No	Yes
Change Manual/Auto Settings	No	No	Yes	Yes
Change Setpoint Values*	No	Yes	Yes	Yes
Change Operating Schedules	No	Yes	Yes	Yes
Lock Out Reset	Yes	Yes	Yes	Yes

Preparing for Upgrading an Existing Chiller

Step 1- Open MCS Supplied Upgrade Kit

(Usually fits in a 16 x 16 x 16 box)

- Verify Packing list of all MCS parts
- Obtain Spiral Binder (Divided 4 sections)
 - Getting Started Manual
 - MCS-PConfig print out (Inputs, outputs, set points, etc)
 - Drawings of each MCS printed circuit board with wiring connections
 - Specification sheet for each MCS part

Step 2- Plan Mounting New Micro

- Keypad / Display
 - Chiller Outside- You should have a Panel mount.
 - Chiller Inside- You should have a Door mount with a Template for mounting
- Mount Electronics in Dry location.
- Do Not Mount in enclosure with Frequency Drive.
- Try to avoid mounting in front of or close to High Voltage Contactors.
- **High Voltage wiring should be run separate from Low Voltage wiring.**
- All wiring to Analog Sensors must be shielded cable.
- When running shielded cable in areas with high voltage avoid running parallel. (Run perpendicular)
- Allow adequate space on all sides of printed circuit boards to run cables.
- If at all possible, avoid splicing shielded cable. If a splice is required please do the following:
 - Splice in an area where no high voltage is within three (3) feet.
 - Splice in a dry area.
 - Splice all wires including Drain wire with butt connectors or solder. (Foil shield need not be connected. Tape connections.) (Stagger where butt connectors are made to avoid bulky connection)
- **GROUND CONNECTIONS**
 - IT IS IMPORTANT TO PROVIDE A GOOD EARTH GROUND TO THE 120 VAC POWER INPUT TO THE PRINTED CIRCUIT BOARDS.
 - DO NOT JUMPER GROUND CONNECTIONS TO PRINTED CIRCUIT BOARDS. EACH PRINTED CIRCUIT BOARD SHOULD HAVE ITS GROUND WIRED DIRECTLY TO GROUND.

Step 3- How To Startup the Machine.

- Relay Output Check - Once the microprocessor has been completely wired a dry test of the wiring should be done. To accomplish this use the following procedure:
 - Keep main power to compressors off. Keep high voltage breakers off or pull fuses to compressors.
 - Turn on 120 Vac control power.
 - Get authorized on the MAGNUM controller. (Either via the keypad or MCS-Connect.)
 - Put each relay output in 'MANUAL ON' and verify the appropriate contactor or solenoid turns on. When testing the wiring to a Liquid Line Solenoid be careful not to leave it on too long if the system uses an expansion valve.)
 - Place each digital sensor input in 'MANUAL ON' to verify the correct value. i.e. 'RUN/STOP', 'FLOW', etc are correct.
 - Verify all analog sensors are within reason.
 - Remove the Packard connector from each pressure transducer. Verify the computer reads minus 99.9P on the correct sensor.
 - Calibrate pressure transducer offsets.
 - If you have any analog outputs verify they are correct. Set analog manual values to '0%, 50%, and 100%'.
- At the completion of the point's checkout, make sure all RO's, SI's & AO's are in 'AUTO' mode.
- Through the keypad, under SERVICE DIAGNOSTICS' clear alarms & point information if you are factory authorized.
- If any circuits are in 'LOCKOUT', reset to clear.
- All setpoints should be displayed on MCS-8 and reviewed for correctness. Specific attention should be paid to the following Setpoints:
 - Verify / set 'FULL LOAD AMPS' (1 per compressor)
 - Verify / set 'TARGET' (supply air / leaving liquid)
 - 'LOW SUCTION, FREEZE', etc based on refrigerant, etc.
 - 'HIGH DISC' based on water or air-cooled.
 - 'Condenser ' setpoints.
- You are now ready to turn on main power.
- Once main power is on verify the following:
 - All relay outputs are in 'AUTO'. (Not "LOCKOUT")
 - FLOW is 'ON' or 'YES'.
 - RUN/STOP is in 'RUN'.
 - Assuming capacity is required the control state should go to 'LOADING'. Once the integration has reached the setpoint the lead compressor will turn on. (If a screw with oil the oil pump will come on 1st.)
 - When the compressor come on the LLS should open. (There may be a pre pump out to eliminate liquid from getting to the compressor. Direct expansion systems.)
 - Watch suction, discharge, amps etc to verify package running OK.
 - If a screw compressor you need to verify if the load & unload pulse timing setpoints need adjusting. The pulse should allow the slide to move so the amps are moving but not overshooting the target. You may need to also adjust the amp dead band setpoints if the system seems to hunt. (For a FLA of 100 amps the amp + & - setpoints should be 3.5. For a FLA of 350 the amp + & - setpoint should be about 10.0.
- Fine-tuning should now be done. (Slope, step delay, control zone, etc setpoints.)

MAGNUM Revision 6.1 & Higher

+12 VDC	RS 485	MCS I/O	Ethernet
---------	--------	---------	----------

PWR Input Terminal

Ten (10) Relay Output terminals. (COMMON, NO,NC)

Spare System Fuse

Twelve (12) Sensor Input Terminals (Analog or Digital)

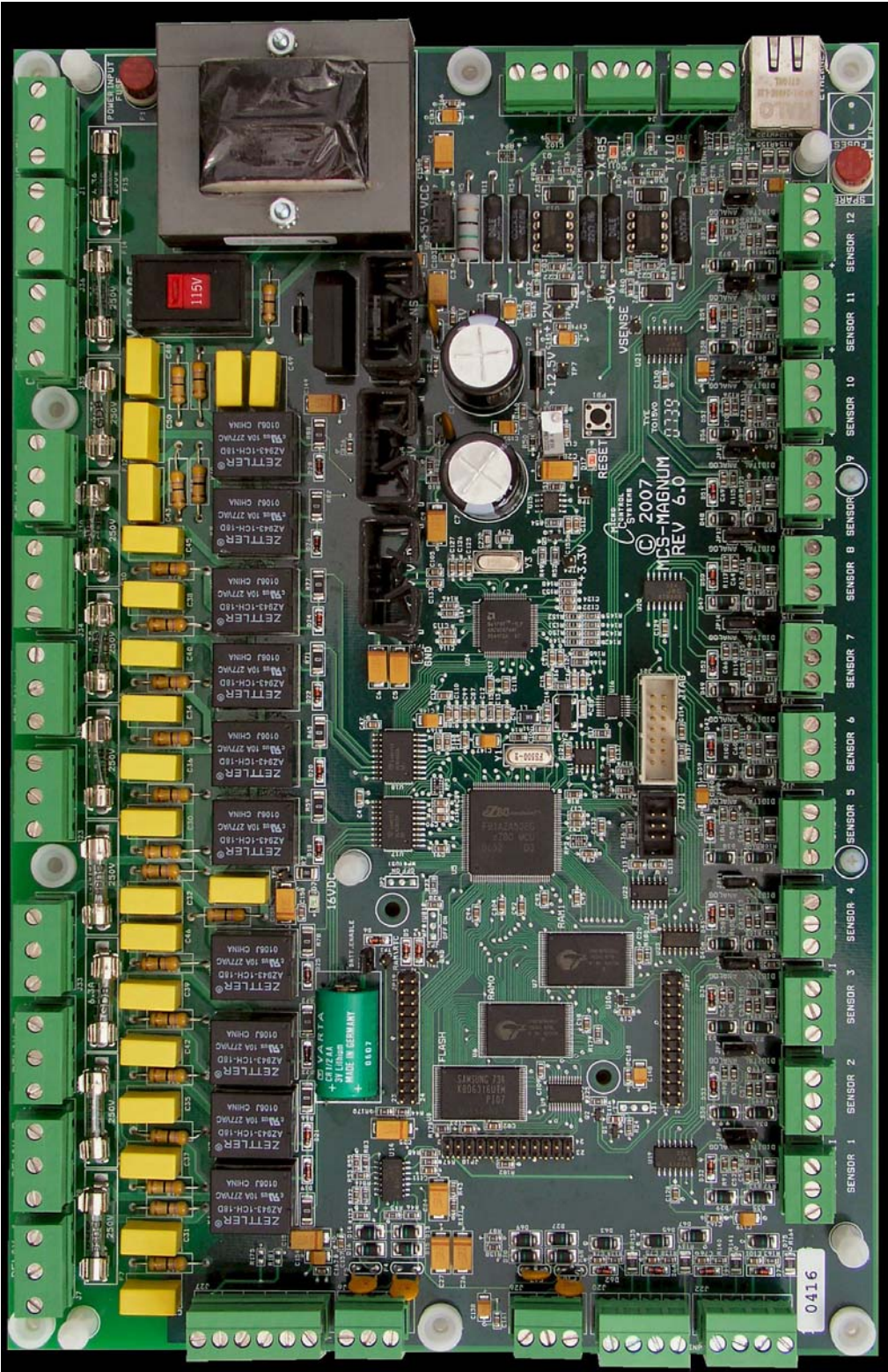

Keypad / Display Wiring

Four (4) Analog Outputs

Four (4) Digital Inputs

The MCS Sensors Quick Reference Sheet

Temperature & Humidity Sensors

MCS-T100 (SI #1 through 8, REV 1.5 & higher)

1. Connects to 1 of MCS Sensor Inputs 1 through 8
2. Shielded cable GND drain must be connected to SI 'GND'
3. Temp MCS-8 SI (inputs 1-8) jumper setting is 'ANALOG'

MCS Sensor Input Terminal Strips

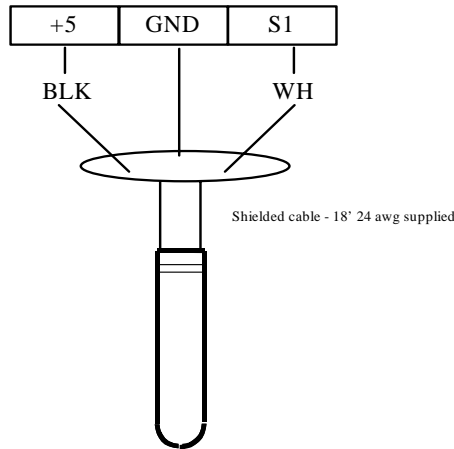

MCS-T100

MCS-ZONE (SI #1 through 8, REV 1.5 & higher)

1. Connects to 1 of MCS Sensor Inputs 1 through 8
2. Shielded cable GND drain must be connected to SI 'GND'
3. Temp MCS-8 SI (inputs 1-8) jumper setting is 'ANALOG'

MCS Sensor Input Terminal Strips SENSOR (x)

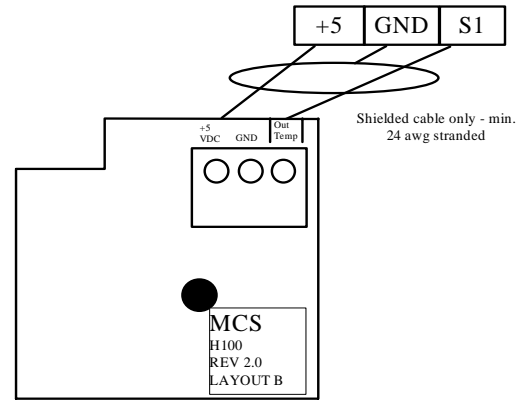

MCS-ZONE

MCS-SAIR (SI #1 through 8, REV 1.5 & higher)

1. Connects to 1 of MCS Sensor Inputs 1 through 8
2. Shielded cable GND drain must be connected to SI 'GND'
3. Temperature MCS-8 SI (input 1-8) jumpers setting to Analog'
4. Minimum extension inside duct 2.25"
5. Normal extension, as shown, 4.00"

MCS Sensor Input Terminal Strips

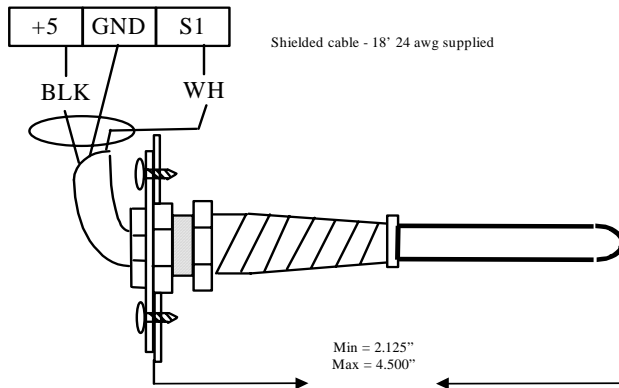

MCS-SAIR

MCS-HUMD (SI #1 through 8, REV 1.5 & higher)

1. Connects to 2 of MCS Sensor Inputs 1 through 8
2. Humidity MCS-8 SI (input 1-8) jumper setting is ANALOG'
3. +5 vdc & GND are common (only one connection required)
4. Temp. MCS-8 SI (input 1-8) jumper setting is 'ANALOG'
5. Shielded cable GND drain must be connected to SI 'GND'

MCS Sensor Input Terminal Strips +12 OUT SENSOR (x1) SENSOR(x2)

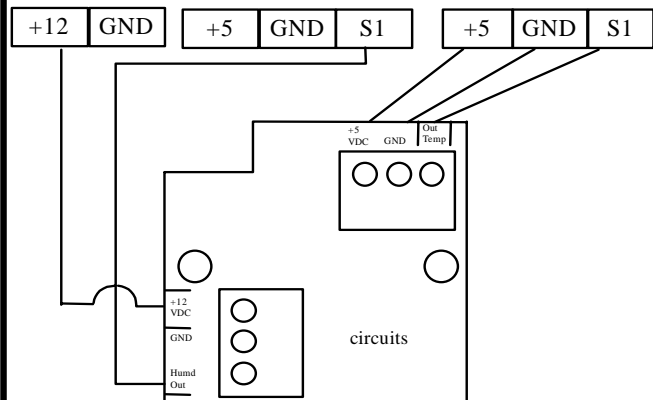

MCS-H100

Pressure Sensor & Digital inputs

MCS-TI-500-xx (SI #1 thru 8, REV 1.5 & higher)

1. MCS-TI-500-xx pressure transducer (3 wire 0-5 vdc)
2. Wiring for 3 wire to SI# 1 through 8
3. Jumper settings for SI# 1 through 8 is 'ANALOG'
4. Pressure range 0 - 500 psi

MCS Sensor Input Terminal Strips
SENSOR (x)

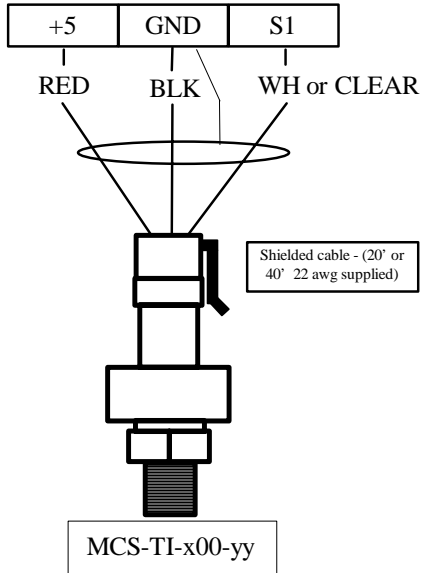

Dry Contact's (SI#1 through 8, REV 1.5 & higher)

1. Digital inputs for use on sensor inputs (SI 1-8)
2. Dry Contact MCS-8 SI (input 1-8) jumper setting is 'DIGITAL'
3. Verify with sensor diagnostic under service on keypad
4. Shielded cable GND drain must be connected to SI "GND"

MCS Sensor Input Terminal Strips
Sensor (x)

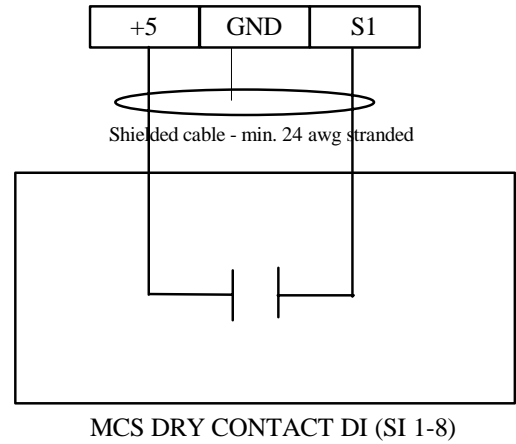

Misc. Printed Circuit Boards

MCS-CT-xxx (SI #1 through 8, REV 1.5 & higher)

1. Connects to 1 of MCS sensor inputs 1 through 8
2. The current transformer may be 100:5 or 250:5
3. The size of the CT (xxx) must be larger than FLA
4. AMPS jumper setting is 'ANALOG'
5. For wiring only remove terminal block. DO NOT REMOVE PRINTED CIRCUIT BOARD.

MCS Sensor Input Terminal Strip Sensor (x)

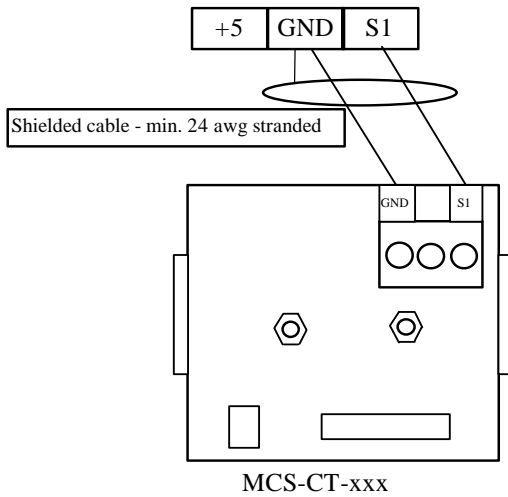

MCS-AOHC (AO, all revisions)

1. The AOHC requires a 12 VDC adequate current source (not 12 volt on MCS8)
2. The AOHC causes the current source to follow the MCS-AO
3. Used for high AMP devices (5 amps DC maximum)

MCS Sensor Output Terminal

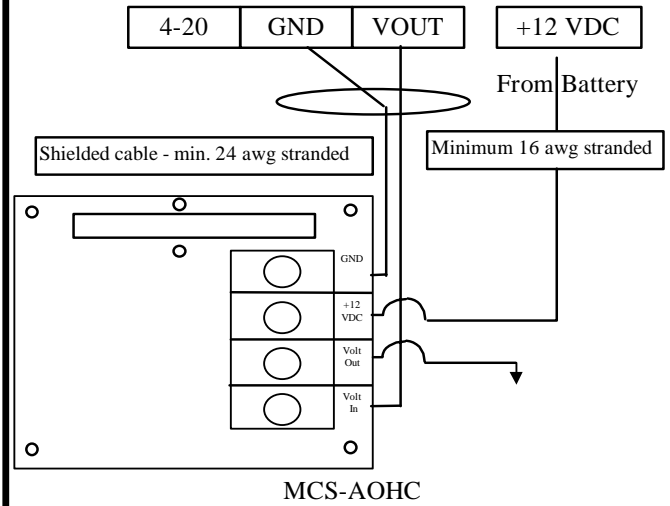

MCS-FREQ (SI #1 through 8, REV 1.5 & higher)

1. Connects to 1 of MCS sensor inputs 1 through 8
2. RPM MCS-8 SI (input 1-8) jumper setting is 'ANALOG'
3. Uses "HOOF" magnetic pickup sensor (9014)
4. For mounting, remove from snap track, mount snap track and cover mounting screw heads to avoid shorting

MCS Sensor Input Terminal Strips

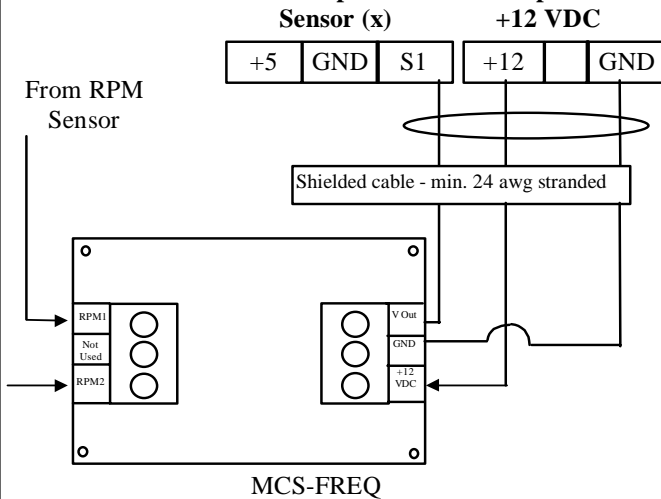

Trouble Shooting Quick Reference Sheet
 (A complete trouble shooting guide is available from our web site)

PROBLEM	POTENTIAL SOLUTION
A sensor input reads -99.9	This indicates an open sensor input signal or 5 VDC problem. <ul style="list-style-type: none"> • Check sensor wiring for missing wire or poor connection. • Check sensor for bad sensor. If less than 5 VDC is on the sensor 5 VDC terminal block, the problem is with probably a shorted sensor. (A poly fuse protects the board) <ul style="list-style-type: none"> • Remove all sensor input terminals. • Wait about 1 min. or until 5 VDC restored at sensor input. • Connect terminals 1 at time until short reappears.
A sensor input reads +999.9	This indicates a shorted sensor input signal. <ul style="list-style-type: none"> • Check sensor wiring for +5VDC shorted to signal etc. • Check sensor for bad sensor.
A sensor is reading less then or greater then 3% off	This indicates the sensor needs to be calibrated. (You need to have a valid Auth code to change sensor offsets) <ul style="list-style-type: none"> • Press Service Diagnostics, press until LCD display s sensor offset option • Press enter, 1st SI# & offset appears (i.e. Suct 1 = 0.0) • Scroll using “increase (+)/decrease (-)” keys to find sensor to be calibrated Press enter, use the “increase (+)/decrease (-)” keys to change the calibration value. When value is correct, press enter.
'MCS CONTROLLER INITIALIZATION' on LCD display.	Indicates Micro in constant reset. <ul style="list-style-type: none"> • Check incoming power > 105 VAC or 22 VAC
Top row of LCD display all bars & 2nd row blank.	Indicates software chip problem possible. <ul style="list-style-type: none"> • Possible U11 software version incorrect or chip bad. • Possible U13 GAL chip incorrect or chip bad. • Possible bad connection or cable between LCD and MCS8
LCD blank.	Indicates bad connection. <ul style="list-style-type: none"> • Connector J2 on MCS not on or offset on connector. • Resistor adjustment VR1 out of adjustment.
Lost I/O	Indicates communications problem. <ul style="list-style-type: none"> • Verify RS485 LED blinking. • Verify termination jumper J6 only on at MCS-8 & last I/O. • Verify MCS-8 & I/O address's set correctly. • Verify wiring from MCS-8 to each I/O correct. • Check fuses/120 VAC on I/O units
Invalid reading on one sensor input.	This indicates an input problem with 1 sensor. <ul style="list-style-type: none"> • Verify jumper settings correct for that SI.
Changes to MCS not being made.	This indicates inability to write to chip U10. <ul style="list-style-type: none"> • Verify 'EEP WRITE ENABLE' jumper W6 is on. • Not authorized
Invalid authorization	This indicates an invalid auth #. Follow steps below for proper authorization <ul style="list-style-type: none"> • Press SERVICE DIAGNOSTICS until the auth. option appears • Press the ENTER key • From the “Display Status” press keys corresponding to your authorization # • Press ENTER

PROBLEM	POTENTIAL SOLUTION
SI from AMPS board 10 A low.	This indicates a problem with this SI only. <ul style="list-style-type: none"> • Jumper setting on this SI in wrong position. • Incorrect sensor type used.
INVALID CONFIG VER	Indicates layout of CFG wrong. <ul style="list-style-type: none"> • CFG layout with check sums are stored in Flash • Verify CFG and reload
INVALID CONFIG TYPE	Indicates CFG type is incompatible with Software selected software. <ul style="list-style-type: none"> • Verify CFG and reload.
INVALID CONFIG	Indicates Checksum invalid <ul style="list-style-type: none"> • Verify CFG and reload
Sensor input believed invalid (Under Sensor Diagnostic Sub Menu)	<ul style="list-style-type: none"> • Verify Berg jumpers using Quick Reference Sheets • Check board version number • Check wiring of sensor