



Magnum Manual Rev. 1.24
Chiller & Condensing Units Software
(HVAC software)

The MCS Commitment

Our commitment is to provide practical solutions for the industries needs and to be both a leader and partner in the effective use of microprocessor controls.

Micro Control Systems, Inc.
5877 Enterprise Parkway
Fort Myers, Florida 33905
PH: (239) 694-0089
FAX: (239) 694-0031
www.MCScontrols.com

(Website contains product descriptions, manuals, software releases, troubleshooting aids, etc)

Information contained in this manual has been prepared by Micro Control Systems, Inc. and is company confidential and copyright © protected 2009. Copying or distributing this document is prohibited unless expressly approved by MCS.

1. Revision Page

Date	Author	Description of Changes
06/09/06	JGW	Created this manual from Standard Chiller Manual Rev.4.9.doc
06/12/06	WTS	Added connecting lines on pages 8 & 9
06/16/06	JGW	General edit + added LCD displays
06/30/06	JGW	Replaced RS 485 pages
10/02/06	JGW	Added Keypad/Display Screens
04/31/07	JGW	Modified drawings for latest Magnum revision.
05/06/07	JGW	Updated Set Points
05/25/07	RCT	Updated Set Points, replaced all reference to PCfg with MAG-Config , added Mixed C/P, added condenser fan bank
08/31/07	RCT	<ul style="list-style-type: none"> - Changed all references of connect or Config programs to MCS-. - Updated set point documentation for new delay counters that use the safety time field. Set points 7,26, 31, 56, 98 & 99. - New liquid injection logic add to options section. - Hot Gas Reheat requiring 3 RO's added to options section. - Economizer with AO added to options section. - Added list of compressor related RO to options section.
01/18/08	JGW	Updated for new features Magnum version 5 software.
01/24/08	BJF	Updated Magnum Info
02/14/08	JGW	Updated Magnum Info
02/27/08	RCT	Corrected Modbus address for Sat Disch and Disch SH for circuits 4, 5 & 6 Added display for defrost items.
08/08/08	RCT	Added information on economizer
09/29/08	RCT	Added information on economizer/fluid cooler and condenser types
10/02/08	BWW	Changed Revision number from 1.13 to 1.14
10/03/08	CAG	Changed Revision number from 1.14 to 1.15
10/03/08	CAG	Updated BMS tables and Settings.
10/30/08	JGW	Corrected set point 76 wording.
11/14/08	CAG	<ul style="list-style-type: none"> • Added new Magnum 6.1 Hardware drawing. • Changed Header for section 22 and 23 (Specified hardware revision) • Corrected The MCS Sensors Quick Reference Sheet. Replaced Mcs-8 to MCS-MAGNUM, 1-11 to 1-12 for analog sensors, and specified that sensors 13-16 are digital only. • Modified BMS section. Sensors Inputs and Set points are not writable. They are read only • Added N2 Points for Oil Pres Diff (Circuit 1thru8) • Added explanations in how to set up Network input sensors • Added drawing for MCS-MAGNUM BMS connections • Removed Appendix A-Magnum Firmware Loader
12-16-08	JGW	Updated Economized set point and documentation
01-14-09	RCT	Updated control states
01-26-09	BWW	<ul style="list-style-type: none"> • Updated Table of Contents • Copied the Economizer setpoint define from section 14 to section 16.36.
02-05-09	RCT	<ul style="list-style-type: none"> • Updated Table of Contents • Added new Economizer set points #107 & 115. • Added alarm option in the RO user defined setup.

02-16-09	RCT	<ul style="list-style-type: none">• Update condenser types with examples• Changed all references to CHL V8 to HVAC• Added suction alarms per common suction groups• Minor corrections• More examples of RO for different compressors
02-25-09	CAG	<ul style="list-style-type: none">• Changed Revision number from 1.21 to 1.22• Change Modbus Relay registers from 10000 to 00000
06-02-09	RCT	<ul style="list-style-type: none">• Added special patterns for 3 & 4 scroll compressors
06-26-09	JLM	<ul style="list-style-type: none">• Add Low Discharge Superheat information to section 17.4.3

2. Table of Contents

1.	Revision Page	2
2.	Table of Contents	4
3.	Introduction	8
3.1.	INTRODUCTION TO MAGNUM CHL V8 SOFTWARE FAMILY	8
3.2.	COMMON SUPPORT ITEMS OF THE CHL V8 SOFTWARE FAMILY:	8
3.3.	ABOUT MAGNUM HARDWARE SUPPORT BY CHL V8 SOFTWARE FAMILY	9
3.4.	ABOUT THIS MANUAL	9
3.5.	ABOUT THE MAGNUM	9
3.6.	ABOUT PC SUPPORT SOFTWARE FOR MAGNUM	9
3.7.	MCS 485 NETWORK	10
3.8.	MCS ETHERNET PORT	10
4.	MCS 485 Communications	11
4.1.1.	MCS 485 Network with Local RS232 Communications	11
4.1.2.	MCS 485 Network with Remote Modem Communications	12
5.	Requirements for PC Software	13
6.	MAGNUM Control Zone Control Method Option	14
6.1.	COMMON DEFINITIONS	14
6.1.1.	Target	14
6.1.2.	Control Zone	14
6.1.3.	Controlling Sensor	14
6.1.4.	The Rate Of Change Of The Control Input	14
6.1.5.	Step Delay	14
6.1.6.	Sensitivity	14
7.	Standard Variable Step Control Method	15
8.	MAGNUM Control States	17
8.1.	MAGNUM KEYPAD & DISPLAY	17
8.2.	STATUS DISPLAY (FROM THE MCS-CONNECT PROGRAM)	19
9.	Capacity Control States (number)	21
10.	Circuit Control States (number)	24
11.	Condenser Control Logic	30
11.1.	CONDENSER INTRODUCTION (REFER TO STANDARD CONTROL OPTIONS SECTION)	30
11.2.	RO STEP CONDENSER CUT IN – OUT LOGIC	31
11.3.	RO STEP CONDENSER WITH VARIABLE SPEED FAN	31
11.4.	MODULATING CONDENSER	32
11.5.	CONDENSER FAN BANK	32
12.	Set point Definitions	33
12.1.	SET POINT ELEMENTS THAT CAN BE VIEWED:	33
12.2.	SET POINT TYPES:	33
12.2.1.	SET POINT	33
12.2.2.	LOCKOUT	33
12.2.3.	ALARM	33
13.	Set points for Magnum Chiller V8 Algorithm (BY Category)	35
13.1.	CONTROL SET POINTS	35
13.2.	EXV CONTROL SET POINTS	36
13.3.	CAPACITY CONTROL SET POINTS	36
13.4.	CONTROL FOR VARIABLE STEP COMPRESSORS SET POINTS	37
13.5.	CONDENSER CONTROL SET POINTS	38
13.6.	SYSTEM TESTING SET POINTS	39
13.7.	COMPRESSOR CONTROL SET POINTS	39
13.8.	COMPRESSOR SAFETIES SET POINTS	40
13.9.	CHILLED WATER PUMP CONTROL SET POINTS	43
13.10.	UNIT SAFETIES SET POINTS	44
13.11.	REVERSED SET POINTS FOR USER DEFINED FUNCTIONS	44
13.12.	OUTSIDE AIR ECONOMIZER (FLUID COOLER) SET POINTS	44

13.13.	SPIT WINDING SET POINTS	45
13.14.	REHEAT (RELATIVE HUMIDITY) SET POINTS.....	45
13.15.	BLOWER CONTROL SET POINTS	45
13.16.	DEFROST CONTROL SET POINTS.....	45
13.17.	HEAT PUMP CONTROL SET POINTS	46
13.18.	CENTRIFUGAL PURGE CONTROL SET POINTS	46
14.	Set points for Magnum Chiller V8 Algorithm (in sequence).....	47
15.	AUTHORIZATION FUNCTION	59
16.	Standard Control Options	60
16.1.	GENERAL OPTIONS	60
16.2.	COMPRESSOR TYPES	60
16.3.	SEQUENCE OF COMPRESSOR RELATED RELAY OUTPUTS	61
16.3.1.	<i>Recip Comp w/Oil</i>	61
16.3.2.	<i>Recip Comp w/o Oil</i>	61
16.3.3.	<i>Screw Comp w/ Oil</i>	62
16.3.4.	<i>Scroll Comp</i>	62
16.3.5.	<i>Hitachi Screw</i>	63
16.3.6.	<i>Bitzer Screw</i>	63
16.3.7.	<i>Hartford Screw</i>	64
16.3.8.	<i>Carlyle Screw</i>	64
16.3.9.	<i>Hanbell-Load NO</i>	65
16.3.10.	<i>Hanbell-Load NC</i>	65
16.3.11.	<i>Hanbell- 3 Solenoid</i>	66
16.3.12.	<i>Centrifugal</i>	66
16.3.13.	<i>Mitsubishi Screw</i>	66
16.3.14.	<i>TubroCor</i>	67
16.3.15.	<i>Trane Screw</i>	67
16.3.16.	<i>McQuay Frame 4</i>	67
16.3.17.	<i>Fu Sheng</i>	67
16.4.	COMPRESSOR OPTIONS	68
16.5.	CONDENSER TYPES	68
16.5.1.	<i>Common Terms</i>	68
16.5.2.	<i>Develop the Control Discharge Pressure</i>	69
16.5.3.	<i>Condenser Related Set Points</i>	70
16.5.4.	<i>No Condenser Type</i>	70
16.5.5.	<i>RO Step Common Type Without a Fan AO</i>	71
16.5.6.	<i>RO Step Common Type With a Fan AO & Condenser Faults</i>	71
16.5.7.	<i>RO Step Individual Type</i>	72
16.5.8.	<i>RO Step Combined Type</i>	73
16.5.9.	<i>Modulating Common Type</i>	74
16.5.10.	<i>Modulating Individual Type</i>	75
16.5.11.	<i>RO Shared Type</i>	76
16.5.12.	<i>Dual V8 Type</i>	77
16.5.13.	<i>Common VFD Fan w/Bypass Type</i>	77
16.6.	CHILLER BARREL HEATER OPTIONS	79
16.7.	HOT GAS BYPASS (SCREW CHILLERS).....	79
16.8.	CHILLED WATER RESET	79
16.9.	TWO EXPANSIONS VALVES PER CIRCUIT OPTION.....	79
16.10.	OIL EQUALIZATION OPTION	80
16.11.	LIQUID INJECTION OPTION.....	80
16.12.	OIL COOLER OPTION.....	80
16.13.	OIL PUMP CONTROL OPTION	80
16.14.	OIL DIFFERENTIAL CALCULATION	81
16.15.	ON/OFF SWITCHES	81
16.16.	LOW SUCTION UNLOADING & HOLDING	82
16.17.	HIGH DISCHARGE PRESSURE UNLOADING & HOLDING.....	82

16.18.	HIGH DISCHARGE TEMPERATURE UNLOADING & HOLDING	82
16.19.	HIGH AMPERE UNLOADING & HOLDING	83
16.20.	LOW WATER TEMPERATURE UNLOADING & HOLDING	83
16.21.	ENERGY EFFICIENT COMPRESSOR STAGING	84
16.22.	CHILLED WATER PUMP CONTROL	84
16.23.	PROCESS PUMP & HEAT EXCHANGER CONTROL	84
16.24.	CONTROL POWER RELAY –NO STOP.....	85
16.25.	PART WIND OR STAR DELTA STARTER	85
16.26.	LOW & HIGH AMBIENT SHUTDOWN	85
16.27.	ENGLISH, METRIC OR MIXED C/P SENSOR READINGS	85
16.28.	COMPRESSOR AUTO ROTATION	85
16.29.	COMPRESSOR ANTI-CYCLE LOGIC.....	86
16.30.	WARNING & ALARM RELAY OUTPUTS	86
16.31.	VI PORT CONTROL LOGIC (OPEN DRIVE SCREW ONLY)	87
16.32.	OPERATING SCHEDULES	87
16.33.	MOD-MOTOR LIMIT CONTROL FOR FLOODED CHILLER.....	87
16.34.	COMPRESSOR LEAD AND ROTATION	87
16.35.	EXHAUST FAN	87
16.36.	HOT GAS REHEAT (HUMIDITY) CONTROL.....	88
16.37.	OUTSIDE AIR ECONOMIZER/FLUID COOLER WITH ANALOG OUTPUT CONTROL	89
16.37.1.	<i>Set up</i>	89
16.37.2.	<i>Sequence Of Operation</i>	91
16.37.3.	<i>Economizer Function Is To Supply Outside Air</i>	92
16.37.4.	<i>Mechanical Cooling Enabled</i>	92
16.37.5.	<i>Termination of the Economizer Function</i>	93
16.37.6.	<i>Example: Fluid Cooler with VFD condenser fan</i>	93
16.37.7.	<i>Example: Fluid Cooler with condenser circuit fans</i>	95
16.38.	EXTRA LIQUID LINE SOLENOID CONTROL	97
16.39.	SPECIAL PATTERN FOR SCROLL COMPRESSORS	97
16.39.1.	<i>The following is a sample of the four-compressor setup:</i>	98
16.39.2.	<i>Pattern of the four-compressor setup:</i>	98
16.39.3.	<i>The three-compressor type will be setup in as follows:</i>	99
16.39.4.	<i>Pattern of the three-compressor setup:</i>	99
16.39.5.	<i>Safeties are the same for both compressor types</i>	99
17.	MAGNUM Alarms and Safeties	101
17.1.	INTRODUCTION.....	101
17.2.	INFORMATION ONLY ALARMS.....	101
17.2.1.	<i>System generated alarms</i>	101
17.2.2.	<i>Alarms as a result of individual action</i>	101
17.2.3.	<i>Alarms generated by the control algorithm</i>	101
17.3.	MAGNUM SYSTEM ALARMS	102
17.3.1.	<i>Alarms are generated by the MAGNUM control algorithm:</i>	102
17.4.	SET POINT SAFETY ALARMS.....	102
17.4.1.	<i>Introduction</i>	102
17.4.2.	<i>Sensor inputs used in conjunction with MAGNUM set point safeties:</i>	103
17.4.3.	<i>Set point safeties</i>	103
18.	Magnum Control States Quick Reference	107
19.	OEM Factory Checkout Procedure	108
19.1.	VISUAL CHECK.....	108
19.2.	MCS POWER ON (COMPRESSOR POWER OFF).....	108
20.	Compressor relay output sequence examples (software)	109
20.1.	HANBELL COMPRESSOR WITH NO	109
20.2.	HANBELL COMPRESSOR WITH NC.....	109
20.3.	HANBELL COMPRESSOR WITH 3 SOLENOIDS	109
20.4.	CENTRIFUGAL COMPRESSOR	109
20.5.	MITSUBISHI MONO SCREW	109

20.6.	SCREW COMPRESSOR WITH OIL	110
20.7.	RECIPROCATING COMPRESSOR.....	110
20.8.	JE HALL SCREW COMPRESSOR WITH SPLIT-WINDING	110
20.9.	HITACHI SCREW COMPRESSOR	110
20.10.	HARTFORD COMPRESSOR (VERTICAL).....	111
20.11.	BITZER COMPRESSOR.....	111
21.	The Magnum Keypad Display Quick Reference	112
22.	The MAGNUM Hardware Rev 1 thru 5 Quick Reference Sheet.....	113
23.	The MAGNUM Hardware Rev 1 thru 5 Quick Reference Sheet.....	114
24.	The MAGNUM Hardware Rev 6 Quick Reference Sheet	115
25.	The MCS Sensors Quick Reference Sheet (Temp & Humidity)	116
26.	The MCS Sensors Quick Reference Sheet (PSI, CT & Digital)	117
27.	The MCS Trouble Shooting Quick Reference Sheet.....	118
28.	BMS Communication Protocols	120
28.1.	SENSOR INPUT POINTS	120
28.2.	RELAY OUTPUT POINTS	121
28.3.	ANALOG OUTPUT POINTS	122
28.4.	SET POINTS.....	123
28.5.	CHILLER/CIRCUIT STATES	127
28.6.	OTHER POINTS.....	127
28.7.	NETWORK INPUTS TO MCS-MAGNUM.....	129
28.8.	MCS CAPACITY CONTROL STATE CHART.....	130
28.9.	MCS COMPRESSOR CONTROL STATE CHART	130
29.	MCS-MAGNUM BMS CONNECTIONS.....	132
29.1.	MCS-MAGNUM BMS PROTOCOLS SETTINGS	133
29.1.1.	<i>Bacnet MSTP:</i>	133
29.1.2.	<i>Bacnet Over IP:</i>	134
29.1.3.	<i>Modbus RTU:</i>	135
29.1.4.	<i>Modbus TCP/IP:</i>	136
29.1.5.	<i>Johnson N2:</i>	137
30.	User Logic.....	138
30.1.	OPERANDS	138
30.2.	USER SENSOR INPUT (USER VAL)	138
30.3.	USER RELAY OUTPUT	138
30.4.	USER ANALOG OUTPUT	139

3. Introduction

3.1. Introduction to Magnum CHL V8 Software Family

Magnum version 5 on the OS Multi Tasking operating System supports either Mechanical Expansion valves, or Electronic Expansion Valves on all Semi-hermetic screw compressors.

- Hanbell
- Hartford
- Hitachi
- Century
- Bitzer
- JE Hall
- RefCom
- etc.),

3.2. Common support items of the CHL V8 Software Family:

- Circuits (compressors) up to 8,
- Steps per Circuit up to 4,
- Relay Outputs up to 48,
- Analog Outputs up to 9,
- Sensor Inputs up to 48,
- Set points 170,
- Alarms 60

3.3. About Magnum Hardware Support by CHL V8 Software Family

The following MCS boards can be connected together via the MCS-I/O communications terminal block:

- MAGNUM with (10 RO's, 12 SI's, 4 DI's & 4 AO's
- MCS-I/O with (8 RO - 8 SI - 1 AO with I/O 7.00-C with a GAL 5.0 chip),
- MCS-RO8 (8 RO),
- MCS-SI16 (16 SI).

This provides flexibility in configuring the individual systems to obtain the desired number of points in the most economical way. The limitation is not the number of boards but the total number of points. Refer to section 3.2.

3.4. About this Manual

The purpose of this manual is to document MCS's CHL V8 software for the Magnum.

This manual documents how the CHL V8 software functions. Since this is a large manual, it is structured in logical sections for ease of reference. The Table of Contents will guide you through the sections but you are urged to read the entire manual. This will provide an understanding of the capabilities of the Magnum Control System and hopefully introduce other ways that you may benefit from the existing control strategies. Quick Reference sheets and MCS Specification sheets are provided in the appendices.

This manual was created using Microsoft Office, Word 2000. A printed copy may be ordered, please refer to our Price Book. A PDF copy of this manual may be down loaded from our web site at www.MCScontrols.com free of charge.

An approved OEM of MCS may make copies and / or change any section of this manual to develop custom documentation for a site where a Magnum controller is installed. In this way, MCS supports the documentation requirements of individual customer sites.

3.5. About the Magnum

The MAGNUM is a rugged microprocessor based controller that is designed for the hostile environment of the HVAC/R industry. It is designed to provide primary control, i.e. no mechanical controls; interfacing with building management systems as well as communicate both locally and remotely. The MAGNUM provides flexibility with set points and control options that can be selected prior to commissioning a system or when the unit is live and functioning. Displays, alarms and other interfaces are accomplished in a clear and simple language that informs the user as to the status of the controller.

The MAGNUM is designed to safeguard the system that is being controlled, eliminate the need for manual intervention and to provide a simple but meaningful man-machine-interface.

3.6. About PC Support Software for MAGNUM

- **MCS-Config** program provides the configuration file: points list, set points, options, etc., for all versions of software. This program is user friendly with English questions and drop down menus. It is written in the Microsoft Visual Basic programming language. A manual created under Microsoft Office, Word 2000, for Windows is available on our web site; www.MCScontrols.com, this is in a PDF format, on diskette or CD-ROM.
- **MCS-Connect** program provides both local and remote communications to the MAGNUM independent of the type of software. Through this program, the status of the controller can be viewed and with proper authorization changes can be made to the system. Configuration files can be transmitted to or received from a MAGNUM unit. The MAGNUM automatically performs history logging; this program will complete graphing functions. A general manual created under Microsoft

Office, Word 2000, for Windows is available on our web site ; www.MCScontrols.com, this is in a PDF format; on diskette or CD-ROM.

Both of these programs run under Windows 2000 or greater and they make use of the Microsoft Windows Help function to assist the user.

3.7. MCS 485 Network

The MCS 485 Network can support up to 20 Magnum's and their associated I/O's. Access to this network can be local, via and RS 232 connection, or remote via a 14.4K Baud modem. When using the dial up through the modem there will be no degradation in the performance of the network. The PC connected to the network must be running Windows 2000 or higher with MCS-Connect providing the actual interface program.

Each Magnum in the network must be assigned a unique address when the configuration file is build using the **MCS-Config** program. This address will be the key in establishing communications with the appropriate MAGNUM system. This address can be changed from the LCD / keypad of the unit.

Notes:

- The current address of a Magnum can be viewed or changed (with Factory authorization) from the SERVICE TOOLS option on the menu display.
- RS 232 transmissions should not exceed 50' in length.
- RS 485 transmissions should not exceed 1 mile without a repeater.

3.8. MCS Ethernet Port

Communications can be through the 100 MBPS Ethernet communications port on the Magnum. It is necessary to use a crossover cable when connected directly to this port from a PC.

4. MCS 485 Communications

4.1.1. MCS 485 Network with Local RS232 Communications

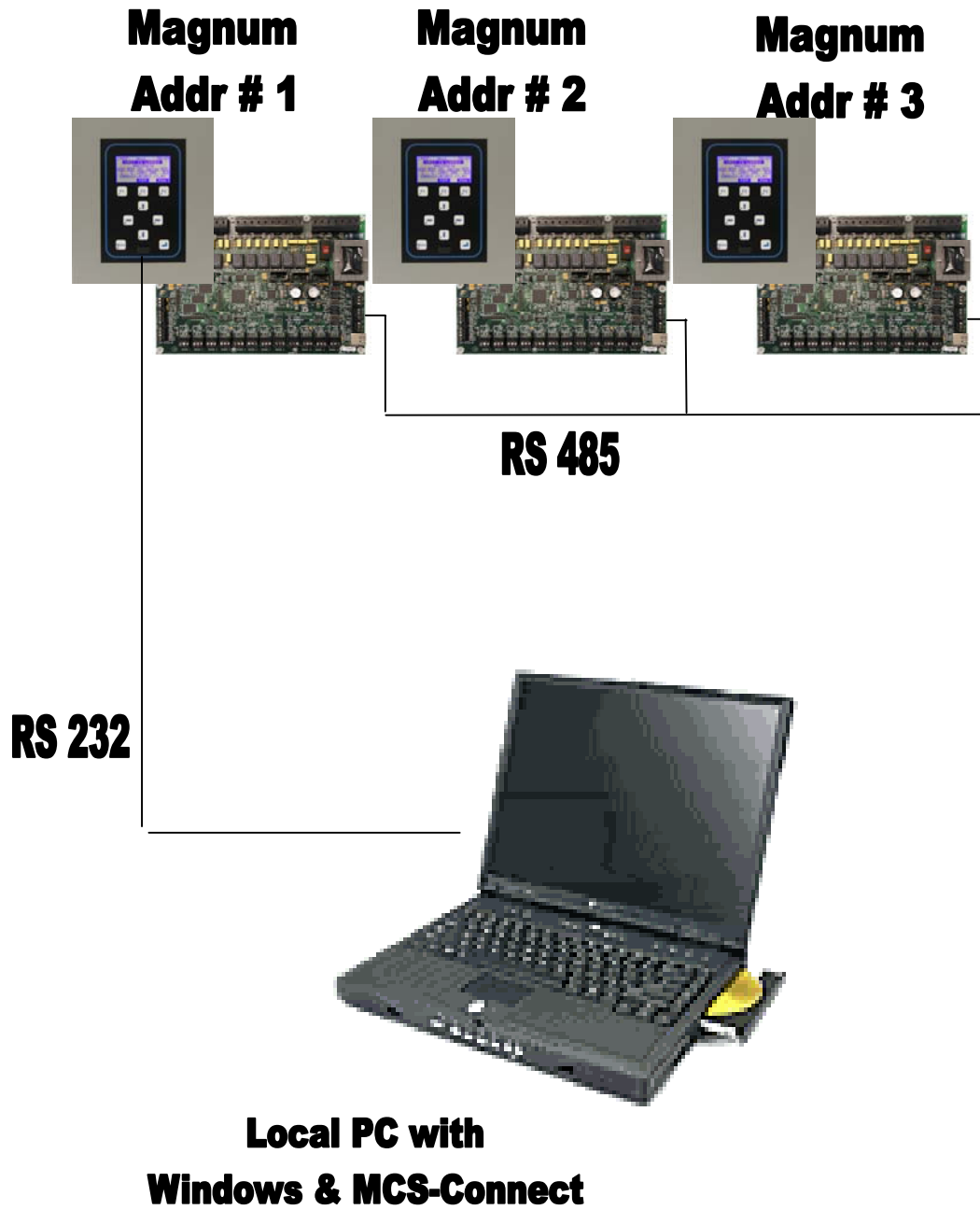

4.1.2. MCS 485 Network with Remote Modem Communications

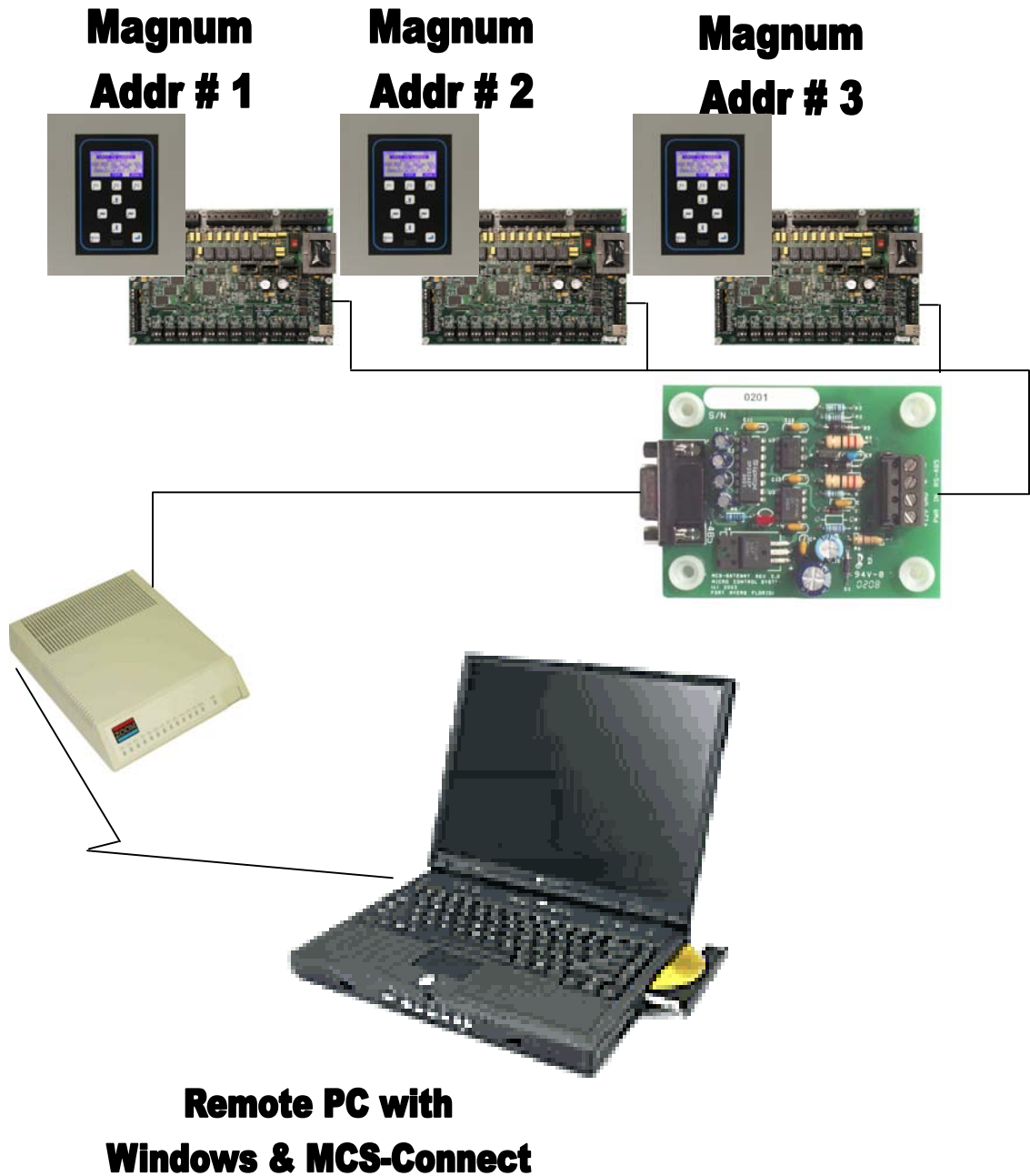

5. Requirements for PC Software



To install and run the program we suggest the following system requirements:

Front End System Requirements

- Windows
- Pentium 166 MHz
- 10 Gigabyte hard disk with at least 25 Megabytes free
- CD Drive
- Super VGA display capable of displaying 256 colors
- 64 Megabytes of RAM or more is recommended
- 33.6k baud modem

Minimum System Required to Run Program

- Windows 2000
- Pentium 1.0 MHz or faster
- 40 Gigabyte Hard Drive
- Super VGA Display capable of displaying 256 colors
- 256 Megabytes RAM
- 56k baud modem

6. MAGNUM Control Zone Control Method Option

This control strategy is based upon developing a control zone and then to step the compressor(s) through their stages to maintain the control sensor reading within this zone. To accomplish this the system will constantly monitor the control value, its rate of change and position in relationship to the control zone.

The actual strategy of a fixed step system, reciprocating compressor, and a variable (slide) step system, screw compressor or a reciprocating compressor with an inverter, is slightly different. The variable step system allows for infinite variations of capacity while the fixed step system does not.

This option is active in all software and is specified in the **MCS-Config** program.

6.1. Common Definitions

6.1.1. Target

The control target is specified in set point 1. This will be the base of developing the control zone.

6.1.2. Control Zone

The control zone is developed by adding the set points for the control target (set point 1) and the dead band + (set point 2) to obtain the upper limit. The lower limit is obtained by subtracting the dead band - (set point 3) set point from the control target (set point 1).

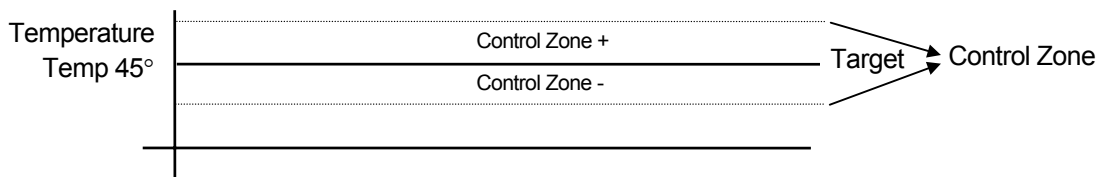

Once the control zone has been established, the system will attempt to keep the control sensor reading within this range.

6.1.3. Controlling Sensor

This is the sensor that has been specified in the **MCS-Config** program as providing the control value reading. It will normally be either the entering, leaving temperature or the suction pressure. The set points must be adjusted to agree with the controlling value.

6.1.4. The Rate Of Change Of The Control Input

The rate of change is how fast the control value is changing over a period of time. If the control value is increasing the rate will be positive, if decreasing the rate will be a negative value. How fast the input is changing, its direction and where the current input reading is in relationship to the control zone will determine what action the system will take.

6.1.5. Step Delay

The system will not attempt to take action until the Step Delay reaches zero. Set point 26 contains the initial value. The speed that it is decrement by is based upon the rate of change of control input value and the sensitivity that has been specified.

6.1.6. Sensitivity

The sensitivity value is contained in set point 25. The purpose of the sensitivity value is to limit or dampen how fast the system reacts to changes indicated by the control sensor. The lower the number, the faster the system will react to changes of the control sensor.

7. Standard Variable Step Control Method

This option is specified in the MCS-Config program

The system will attempt to keep the control value within the control zone that has been developed by calculating the required system capacity. The system capacity will be based upon the number of circuits (compressors) that are wanted on. When the first, or an addition compressor is turned on, the system capacity will be set to the calculated value. For the 1st compressor this will be the set point 31 value. For additional compressors this will be calculated to provide the same capacity prior to the change. The system will adjust the required capacity between the calculated and the maximum value as specified in set point #30, MAX SLIDE %. All compressors that are on will be adjusted together to meet the system capacity.

When the maximum capacity value has been reached, an additional compressor, if available, will be wanted on. The number of compressors wanted on will be increased by one and the system capacity will be set to the calculated value and the sequence will began again. Once all available compressors are on, their maximum will be 100% regardless of the value in set point #30, MAX SLIDE %.

When the minimum calculated value has been reached, a compressor will be turned off. This will occur when the reduced number of compressors can achieve the same capacity at 90%. The number of compressors wanted on will be decreased by one and the system capacity will be set to 90% and the sequence will began again.

The compressor slide control is based upon the amps drawn of that compressor. For example, if set point #31, MIN SLIDE %, is set to 30%, that is 30% of the calculated full load amp for that compressor. An acceptable zone for the amp draw is developed based upon the desired capacity and set points #35 and #36. If the amp drawn is greater than the indicated capacity needed then the compressor is unloaded. Conversely if it is less, then it is loaded.

The compressors that are on are either loaded, their load solenoids are pulsed; unloaded, their unload solenoids are pulsed or are in a hold state, no action is required. The state of each circuit (compressor) reflects this action.

Set points for controlling Variable Step Compressors

30	MAX SLIDE %	Indicates the maximum slide or speed allowed. Usually set to 100%.
31	MIN SLIDE %	Indicates the minimum slide or speed allowed. Usually 50%. This is where the slide valve or the inverter will be set when the compressor is turned on.
32	MAX ADJUST %	Indicates the maximum percentage change that can be made to the slide valve or the inverter when more cooling capability is needed.
33	MIN ADJUST %	Indicates the minimum percentage change that can be made to the slide valve or the inverter when less cooling capability is needed.
34	SLIDE SENSITY	This allows control of the adjustment made to slide wanted percentage. The adjustment is relative to the difference between current leaving liquid temperature and target. The larger the value the larger the adjustment.
35	AMP DB HI	This set point is only used in the screw compressors. This value is the upper dead band limit to stop pulsing the slide valve. If the actual amps are within the dead band, the slide valve will not be moved.
36	AMP DB LO	This value is the lower dead band limit to stop pulsing the slide valve. If the actual amps are within the dead band, the slide valve will not be moved.
37	LOAD PULSE	Length of time to turn on the slide valve load solenoid. Time is expressed in 1/10 of a second.
38	UNLOAD PULSE	Length of time to turn on the slide valve unloader solenoid. Time is expressed in 1/10 of a second.

39	LUBE OIL TMP	Used only with screw compressors with oil, the oil must reach this temperature before the system will move out of the LUBE state.
40	LUBE OIL PSI	Used only with screw compressors with oil, the oil must reach this pressure before the system will move out of the LUBE state.
41	LUBE DELAY	Used only with screw compressors with oil, this is the maximum time that a compressor can be in the LUBE state. When this time is exceeded, an alarm is generated and the circuit is placed in a lockout state. Both the oil temperature and pressure must be satisfied before the LUBE state will be exited.

Example of a system with 3 variable Step Compressors, Stage 1 is the current lead compressor. (Example below assumes compressor 1 is the current lead compressor.)

STAGE 1

Compressor 1's startup procedure has begun. Once on, and then its capacity will be varied from the minimum to the maximum. All other compressors will be off. The steps wanted on / actual will be 1 / 1.

STAGE 2

Compressor 2's startup procedure has begun. Once on, the system capacity will be changed to the calculated % and compressor 1 will be unloaded until it matches the calculated system capacity. Both compressors will be varied from the calculated to the maximum. All other compressors will be off. The steps wanted on / actual will be 2 / 2. If the system capacity has been reduced to 45%, or the calculated % (which ever is larger) and less capacity is needed, a compressor will be turned off and the system capacity will be set to the 90% or the maximum and the system will return to Stage 1.

STAGE 3

Compressor 3's startup procedure has begun. Once on, the system capacity will be changed to the calculated % and compressors 1 and 2 will be unloaded until they equal the required capacity. All compressors will be varied from the calculated to 100%. The steps wanted on / actual will be 3 / 3. If the system capacity has been reduced to 60%, and less capacity is needed, a compressor will be turned off and the system capacity will be set 90% and the system will return to Stage 2.

8. MAGNUM Control States

The MAGNUM controller is a state computer, that is, decisions are made based upon set points, timers and sensor inputs, the controller moves from one state to another. The controller will change states to ensure the proper functioning of the chiller package.

As we review the various states, we must remember that a chiller package consists of a number of different parts or functions: the compressors and their related items such as unloaders hot gas bypasses, etc.; evaporator; and condensing functions. To control these functions the states will be divided into three sections:

- Capacity Control States
- Circuit Control States
- Condenser Control States

Both the CAPACITY CONTROL STATES and CIRCUIT CONTROL STATES are displayed on the STATUS option on the graphic's LCD. To view the state of the chiller select the STATUS option from the MENU on the keypad. You can then view the entire status by using the page up / down function keys. The information can also be accessed via the MCS-Connect program under status screen by clicking on the CONTROL STATUS button.

8.1. Magnum keypad & display

A. THE CURRENT STATE OF THE PACKAGE & CIRCUITS.

This is the default screen and the following will be displayed. The 1st display shows the current capacity of the package and how long we have been at this level. By pressing the **PG↑** OR **PG↓** you will get additional information on each circuit.

ACTUAL DISPLAY

09:55	Unit	45/54
UNIT IS UNLOADED		
025:42;33		
<u>WTD</u>	<u>ACT</u>	<u>WTD%</u> <u>DLY</u> <u>ROC</u>
0	0	40% 180 0.0
TARGET=45.0 (ADJ +0.0)		
PG↑		PG↓

DESCRIPTION

HH:MM	CHILLER UNIT		LEV/ENT
CURRENT CONTROL STATE			
TIME IN CURRENT STATE			
<u>WANTED</u>	<u>ACTUAL</u>	<u>WANTED%</u>	<u>DELAY</u> <u>SLOPE</u>
#STEPS	#STEPS	ACTUAL%	NEXT CHG DIRECTION
TARGET SET POINT + TARGET RESET			
PAGE UP			PAGE DN

09:56	CMP #1	45/54
CMP OFF/READY		
000:00;30		
<u>SUCT</u>	<u>DISC</u>	<u>OPD</u> <u>MOTOR</u>
66P	190P	134P 0%
55F	177F	---- OK
PG↑		PG↓

HH:MM	CIRCUIT		LEV/ENT
CURRENT CONTROL STATE			
TIME IN CURRENT STATE			
<u>SUCTION</u>	<u>DISCHARGE</u>	<u>OIL DIFFERENTIAL</u>	<u>MOTOR</u>
PRESSURE	PRESSURE	PRESSURE	AMP %
TEMPERATURE	TEMPERATURE	----	STATUS
PAGE UP			PAGE DN

09:55	CMP #1	45/54
CMP OFF/READY		
000:00:42		
<u>SST</u>	<u>SSH</u>	<u>SCT</u> <u>DSH</u>
38	16.9	97 79.2
PG↑		PG↓

HH:MM	CIRCUIT		LEV/ENT
CURRENT CONTROL STATE			
TIME IN CURRENT STATE			
<u>SAT.SUCT.</u>	<u>SUCT SHEAT</u>	<u>SAT.COND.</u>	<u>DISC SHEAT</u>
TEMP	TEMP	TEMP	TEMP
PAGE UP			PAGE DN

09:55	EXV #1	45/54	
	IS HOLDING		
	000:36:42		
<u>VLV%</u>	<u>DELAY</u>	<u>SPHT</u>	<u>ROC</u>
27	60	12.2	0.0
	PG↑		PG↓

HH:MM	ELECTRONIC EXP VLV	LEV/ENT
	CURRENT CONTROL STATE	
	TIME IN CURRENT STATE	
<u>VLV OPEN%</u>	<u>TIME DELAY</u>	<u>SUCT SHEAT</u>
PERCENT	DELAY NEXT CHG	TEMP
		ROC
		CHG OVER TIME
	PAGE UP	PAGE DN

B. The MENU KEY.

The result below is obtained when pressing the 'Menu' key.

ACTUAL DISPLAY

DESCRIPTION

09:55	Main Menu
-Status	-Setpoints
-Outputs	-Serv Tools
-Inputs	-Lckout RST
-Alarms	-Lckout ALM
-Graphs	-Passwords
Help	

HH:MM	Main Menu
-Control Status Display	-Set Point Display
-Relay & Analog Output Display	-Service Tools Display
-Sensor Input Display	-Lockout Reset Display
-Alarm Display	-Lockout Alarms Display
-Graph Display	-Password Display

FOR ADDITIONAL INFORMATION ON THE KEYPAD / DISPLAY

PLEASE SEE

'Magnum Keypad-Display Manual'

8.2. STATUS Display (from the MCS-Connect program)

The status of the CAPACITY CONTROL STATES, CIRCUIT CONTROL STATES and EXV CONTROL STATES can be viewed from the MCS-Connect program by accessing the CONTROL STATUS key under status screen. The following will be displayed:

PC-Connect for the MCS-8 Status Screen Authorization is at Factory Level

Addr #3 TUE JUN 13, 06 09:22:45 **MAGNUM TEST** EDGEWOOD

RELAY OUTPUTS	VALUE	MANUAL STATUS	LAST ON	LAST OFF	RUN TODAY	CYCLES TODAY	RUN YESTERDAY	CYCLES YESTERDAY	SENSOR INPUTS	VALUE	MANUAL STATUS	OFFSET	SENSOR TYPE	LAST ON/ MAX TODAY	LAST OFF/ MIN TODAY	RUN TDY/ AVG TDY	CYCLES TODAY	RUN MAX
M-1	COMP1	ON	AUTO	21:19:23	11:53:32	09:21:24	0	05:35:18	M-1	SUCT1	39.9P	AUTO	-3.0P	TI-200	42.8P	37.2P	39.3P	
M-2	LOAD1	OFF	AUTO	21:30:27	21:30:27	00:00:00	0	00:00:38	M-2	DISC1	201.5P	AUTO	1.0P	TI-500	230.8P	196.1P	215.3P	
M-3	UNLOAD1	OFF	AUTO	21:26:28	21:26:28	00:00:00	0	18:24:51	M-3	AMPS1	90.1A	AUTO	0.0A	CT-250	98.1A	88.3A	93.5A	
M-4	LLS1	ON	AUTO	21:19:43	11:53:15	09:21:24	0	05:34:21	M-4	SUCTTMP1	26.5F	AUTO	0.0F	MCST100	34.2F	24.8F	27.0F	
M-5	COMP2	ON	AUTO	21:25:26	11:53:30	09:21:24	0	05:24:14	M-5	DISCTMP1	149.3F	AUTO	0.0F	MCST100	156.6F	146.6F	153.1F	
M-6	LOAD2	OFF	AUTO	09:21:59	09:21:59	00:51:51	3111	00:00:17	M-6	MOTFLT1	NO	AUTO		DIGITAL	00:00:00	00:00:00	00:00:00	0
M-7	UNLOAD2	OFF	AUTO	21:30:44	21:30:44	00:00:00	0	18:35:48	M-7	PUMPDWN1	NO	AUTO		DIGITAL	00:00:00	00:00:00	00:00:00	0
M-8	LLS2	ON	AUTO	21:25:46	11:53:14	09:21:24	0	05:23:18	M-8	COMP0IL1	164.0P	AUTO	0.0P	TI-500	190.8P	158.5P	176.5P	
M-9	FAN1-1	ON	AUTO	21:20:27	11:53:31	09:21:24	0	05:33:05	M-9	ENT LIQ	32.6F	AUTO	0.0F	MCST100	34.5F	29.6F	31.5F	
M-10	FAN1-2	ON	AUTO	21:20:51	11:53:31	09:21:24	0	05:31:36	M-10	LEV LIQ	27.2F	AUTO	0.0F	MCST100	28.9F	24.1F	25.8F	
M-11	FAN1-3	ON	AUTO	21:21:59	11:53:31	09:21:24	0	05:29:45	M-11	AMBIENT	75.8F	AUTO	0.0F	MCST100	85.0F	75.1F	82.0F	
M-12	FAN1-4	ON	AUTO	21:23:11	11:53:31	09:21:24	0	05:27:46	M-12	FLOW	YES	AUTO		DIGITAL	00:00:00	00:00:00	09:21:26	0
M-13	FAN1-5	ON	AUTO	21:25:03	11:53:31	09:21:24	0	05:17:01	M-13	RUN/STOP	RUN	AUTO		DIGITAL	21:18:49	11:53:07	09:21:26	0
M-14	FAN2-1	ON	AUTO	21:26:46	11:53:29	09:21:24	0	05:21:18	M-14	PHASLOSS	NO	AUTO		DIGITAL	00:00:00	00:00:00	00:00:00	0
M-15	FAN2-2	ON	AUTO	21:26:52	11:53:29	09:21:24	0	05:21:06	M-15	SUCT2	38.7P	AUTO	0.0P	TI-200	46.8P	36.0P	39.8P	
M-16	FAN2-3	ON	AUTO	21:27:43	11:53:29	09:21:24	0	05:19:40	M-16	DISC2	209.1P	AUTO	0.0P	TI-500	243.2P	198.1P	225.0P	
M-17	FAN2-4	ON	AUTO	21:29:31	11:53:29	09:21:24	0	05:16:30	M-17	AMPS2	87.3A	AUTO	0.0A	CT-250	98.1A	84.2A	92.0A	
M-18	FAN2-5	ON	AUTO	21:30:33	11:53:29	09:21:24	0	05:14:08	M-18	SUCTTMP2	23.5F	AUTO	0.0F	MCST100	32.8F	21.8F	25.9F	
									M-19	SUCTTMP2	109.0F	AUTO	0.0F	MCST100	164.8F	104.2F	135.2F	
									M-20	MOTFLT2	NO	AUTO		DIGITAL	00:00:00	00:00:00	00:00:00	0
									M-21	PUMPDWN2	NO	AUTO		DIGITAL	00:00:00	00:00:00	00:00:00	0
									M-22	COMP0IL2	184.1P	AUTO	0.0P	TI-500	206.0P	170.1P	192.9P	
									M-23	SPARE2-1		AUTO	0	SPARE	-999	-999	-999	
									M-24	SPARE2-2		AUTO	0	SPARE	-999	-999	-999	
									M-25	SPARE2-3		AUTO	0	SPARE	-999	-999	-999	

CAPACITY CONTROL STATE	TIME	WANTED	STEP	WANTED	RATE OF	CONTROL	MODE
UNIT IS LOADED	12:03:06	2 / 2 of 2	300	100%	0.0	ENT LIQ	CHILLER
CIRCUIT STATE	TIME	OIL DIFF	FLA %	SLIDE			ACCUM
1) -CMP IS HOLDING	11:56:30	124.1P	100%				4
2) CMP IS HOLDING	01:13:42	145.4P	96%				

CIRCUIT SUCTION TEMP	SATURATED SUCTION	SUCTION SUPERHT	DISC TEMP	SATURATED DISCHARGE	DISC SUPERHT	Ref Temp is:
1) 26.5	16.8	9.6	149.3	101.8	47.5	
2) 23.5	15.7	7.8	108.8	104.1	4.7	

DEFROST STATE	TIME	VALVE %	SUPERHEAT	SHEAT ROC	ADJ DELAY
1) EXV IS HOLDING	00:21:50	35.3%	9.7	0.0	80
2) EXV IS CLOSING	00:00:24	36.0%	7.8	0.0	56

Information on Control States and the status of the system.

STATUS / ALMS / ST PNTS / RESET/CLEAR /

EXIT SYS INF PRT->File GRAPH TRANSMIT RECEIVE SCHED DIAG AUTH

The above display is split as follows:.

- The top line defines the MCS-Connect screen followed by the authorization level
- The next line provides the Magnum address, the day of week & time from Magnum, the company name followed by the site name.
- The upper left quadrant provides the relay output data.
- The upper right quadrant provides the sensor input data.
- The lower left provides the analog outputs and below that the MCS-Connect notification information.
- The lower right provides four screens depending on the tab selected. (Status, Alarms, Set Points & Reset)
- The bottom tab bar provides function selection within MCS-Connect.

The Control Status portion of the Status screen is shown below.

CAPACITY CONTROL STATE	TIME	WANTED /ACTUAL	STEP DELAY	WANTED FLA %	RATE OF CHG)	CONTROL ON	MODE
UNIT IS LOADED	12:03:06	2 / 2 of 2	300	100%	0.0	ENT LIQ	CHILLER
CIRCUIT STATE	TIME	OIL DIFF	FLA %	SLIDE			ACCUM
1) <-CMP IS HOLDING	11:56:30	124.1P	100%				4
2) CMP IS HOLDING	01:13:42	145.4P	96%				
CIRCUIT SUCTION TEMP	SATURATED SUCTION	SUCTION SUPERHT	DISC TEMP	SATURATED DISCHARGE	DISC SUPERHT	Ref Type is: R22	
1) 26.5	16.9	9.6	149.3	101.8	47.5		
2) 23.5	15.7	7.8	108.8	104.1	4.7		
DEFROST STATE	TIME	VALVE %	SUPERHEAT	SHEAT ROC	ADJ DELAY		
1) EXV IS HOLDING	00:21:50	35.3%	9.7	0.0	80		
2) EXV IS CLOSING	00:00:24	36.0%	7.8	0.0	56		

Chiller information:

- **CAPACITY CONTROL STATE** - State of chiller
- **TIME** - time in that state, if the state is UNIT IN POWER UP time will decrement to zero
- **STEPS WANTED ON / ACTUAL ON-** Number of steps wanted on verses the actual steps turned on verses the total steps on the chiller.
- **STEP DELAY** – value that is counted down. The sensitivity and where the control sensor is in relationship to the control zone will determine the speed of the count down. When the value decrements to zero, the system will determine if a change in the systems capacity is required.
- **WANTED SLIDE %** - Wanted slide percentage
- **RATE OF CHNG** – Rate of Change of control sensor, the speed at which the control sensor is changing.
- **CONTROL ON-** The sensor we are controlling to.
- **MODE-** Type device.

Circuit information (all active circuits will be displayed):

- **CIRCUIT NUMBER AND STATE** - Circuit number and state.
- **TIME** - time in that state, if the state is CMP ANTICYCLE time will decrement to zero.
- **OIL DIFF** - Oil differential pressure. Oil differential pressure is calculated as follows:
Semi hermetic screws; Oil PSI – Suction PSI or Discharge PSI – Suction PSI.
Open drive horizontal and Carlyle screw compressor: Oil PSI – Discharge PSI.
Reciprocating compressor: Oil PSI - Suction PSI
All Others: Oil PSI - Discharge PSI.
- **LEAD:** (←) indicates the lead compressor.
- **FLA %:** Full Load Amps based on the set point. (For screw compressors this is based on FLA at current conditions.)

Circuit SUPERHEAT information (all active circuits will be displayed):

- **Suction Temp** – Circuit number and current valve of the Suction Temperature, if available.
- **Saturated Suction**– Calculated Suction Saturated Temperature. (R22, R134a, R407c, And R410a are supported).
- **Suction SuperHt** – Calculated Suction SUPERHEAT, only available if both the Suction Temperature and the Suction Pressure are used. The calculation is Suction Temperature minus the Suction Saturated Temperature.
- **Disc Temp** – Discharge Temperature, if available.
- **Saturated Discharge**– Calculated Discharge Saturated Temperature (R22, R134a, R407c, And R410a are supported).
- **Disc SuperHt** – Discharge SUPERHEAT, is available if both the Discharge Temperature and the Discharge Pressure are used. The calculation is Discharge Temp minus the Discharge Saturated Temp.

Note1: Condenser control is extremely important. The discharge temperature must achieve 117 F and the discharge superheat needs to achieve about 20 F to guarantee good oil separation.

Note2: Condenser staging is critical if the Magnum is to function in different climates. The best option for air cooled chillers is to have each fan on its own contactor and a frequency drive on fan 1. This combination allows the most optimum control in all weather. Also if a contactor is lost only 1 fan is lost.

9. Capacity Control States (number)

UNIT IN POWER UP (0)

This state is entered when the MAGNUM is powered up or the system has been reset. The system will remain in this state for the time specified in set point POWER DELAY, set point 23, or if not active for 60 seconds. In this state all points (RO's) are turned off. This is a time delay to insure the micro has stable power before starting the algorithm.

UNIT IN LOCKOUT (3)

This state is entered whenever a critical situation is encountered that could cause harm to the chiller package. Items such as freeze protect and emergency stop will force the system into this state. Lockouts can be reset without authorization from the keypad or MCS-Connect program; however if the lockout condition has not been corrected, the system will again be forced into the LOCKOUT state. In this state, all RO's except ALARM RO and the OIL HEATER RO for screws with an oil pump are turned OFF & placed in the 'LOCKOUT' state. NOTE: If the Lockout Reset is pressed more than 5 times in a day the unit cannot be reset except thru the MCS-Connect program and requires Factory authorization.

RUN NOT ALLOWED (1)

This is a valid state only with REFR magnum software not with HVAC magnum software. This state will never occur in with this software.

NO RUN- I/O LOST (2)

This state will be entered whenever the MAGNUM loses communications with any of the I/O boards that are connected via the MCS I/O network. When this state is entered the system will generate an MCS I/O off line alarm, which identifies which I/O is off-line and a lost I/O shutdown alarm which locks out the unit. The lockout-reset key must be depressed to reset the system, after the lost I/O has been corrected. In this state, all RO's except ALARM RO & OIL HEATER RO are turned OFF.

RUN/STOP SW OFF (9)

This state is entered when the run stop switch is off, in the stop position. When the chiller is in this state, the individual circuit states if active are moved to the CMP IS OFF state through the normal states. One capacity STEP will be moved per second.

NO RUN – SAFETY (8)

This state is entered when a smoke alarm has been detected. In the MCS Configuration file the Smoke Alarm Indicator must be selected in the Evaporator Information section under the MAG CHL button. When this sensor is on indicting the smoke alarm condition an error message, OFF-SMOKE ALARM, is generated and the unit state is changed.

SCHEDULED OFF (10)

This state is entered when the schedule is calling for the package to be off. When the chiller is in this state, the individual circuit states if active are moved to the CMP IS OFF state through the normal states. One capacity STEP will be moved per second.

OFF- NO EVAP FLOW (11)

This state is entered when the evaporator flow switch is off. When the chiller is in this state, the individual circuit states if active are moved to the CMP IS OFF state through the normal states. One capacity STEP will be moved per second. If the NO FLOW set point is active and set to Lockout the chiller will lockout on no flow.

OFF- NO COND FLOW (12)

This state is no longer valid. It will never occur with this software.

AMBIENT OFF (13)

This state is entered when the ambient temperature falls below the LOW AMB OFF set point #24 or is above the HIGH AMB OFF set point #26. System will remain in this state until the ambient temperature

if low rises 5.0F or 2.5C degrees above the LOW AMB OFF set point value or if high drops 5.0F or 2.5C degrees below the HIGH AMB OFF set point value. When the chiller is in this state, the individual circuit states if active are moved to the CMP IS OFF state through the normal staging function. One capacity STEP will be moved per second.

PROCESS HEAT OFF (14)

This is a valid state only with REFR magnum software not with HVAC magnum software. This state will never occur in with this software.

UNIT IS OFF (4)

This state is entered when the system has moved from a STARTUP, DISABLE, LOCKOUT or LOST I/O state. The chiller is now ready to move into an active state to meet the capacity required.

UNIT IS HOLDING (5)

This state is entered when one of three conditions exists:

- 1) The control sensor reading is being maintained with in the control zone.
- 2) Control sensor reading is above the control zone but the Rate of Change is less than the value in the (MAX ROC-, #27) set point. This indicates that the temperature is decreasing toward the target at an acceptable speed. Therefore, no additional cooling is needed at this time.
- 3) The temperature is below the control zone but the Rate of Change is greater than the (MAX ROC+, #28) set point. This indicates that the temperature is increasing toward the target. Therefore, no reduction in cooling is needed at this time.

This state indicates that there is no need to adjust the cooling capacity of the chiller package. This state will be exited when more or less capacity is required.

UNIT IS LOADING (7)

This state is entered when more capacity is required. Every second an adjustment is made to the step delay. When the delay reaches zero, the counter 'steps wanted on' is increased by 1.

UNIT IS LOADED (16)

This state is entered when all of the systems available capacity steps are on and the package is providing the maximum amount of cooling capacity.

UNIT UNLOADING (6)

This state is entered when less capacity is required. Every second an adjustment is made to the step delay. When the delay reaches zero, the counter 'steps wanted' on is decreased by 1.

UNIT IS UNLOADED (15)

This state is entered when all of the systems available capacity steps are off. The package is providing no cooling capacity, as none is required. The system is ready to react to cooling needs.

UNIT SMOKE UNLDG (20)

This state is entered when a smoke alarm has been detected. It will force a quick unload of the system. In the MCS Configuration file the Smoke Alarm Indicator must be selected in the Evaporator Information section under the MAG CHL button. When this sensor is on indicting the smoke alarm condition an error message, OFF-SMOKE ALARM, is generated and the unit state is changed.

UNIT OFF UNLDING (21)

This state is entered when the unit has been disabled. It will force a quick unload of the system. This state indicates why the unit is unloading.

UNIT DMD UNLDING (22)

This state is only entered when the demand limiting input has been selected. The demand limit sensor must be selected in the General Information section under the MAG CHL button. This input will indicate the maximum number of steps that the unit can have on. If this value is less than the number of steps that are on, the unit will unload to meet this value. This state indicates why the unit is unloading.

UNIT HEAT UNLOADING (23)

This state will be entered if the system is in the heating mode and the actual control temperature is greater than control temperature set point plus the value of set point #164 and the system is not fully unloaded. This state indicates why the unit is unloading.

OFF TMP-ICE MADE (17)

This state is entered when target temperature has been satisfied.

ECONOMIZER ONLY (18)

This state is entered when mechanical cooling is off and the economizer has been specified in the MCS Configuration setup and it is being used for cooling. Refer to the section on Economizer.

SWITCHING MODES (19)

This state is entered when the unit is switching between cooling mode and heating mode.

10. Circuit Control States (number)

Refer to the section in MCS Control States and Relay Output Sequence Quick Reference for an overview of which states are active.

The action of the circuit control states actually result in more, less or no change in the amount of cooling /heating capacity. The CAPACITY CONTROL STATES dictate how the individual circuits move within their states.

CMP LOCKED OUT (1)

This state is entered when the Capacity Control State is LOCK OUT or a safety set point for this circuit has indicated that a critical situation has been encountered. Set points such as (LOW SUCTION #77) or (HI DISCH PSI #81) are examples of safety set points. Lockouts can be reset without authorization from the keypad or MCS-Connect program; however if the lockout condition has not been corrected, the circuit will again be forced into the LOCKOUT State.

LOST IO LOCKED (0)

This state is entered when the Capacity Control State is LOST IO. Lockout reset key will move the circuit to the OFF state. Lockouts can be reset without authorization from the keypad or MCS-Connect program; however if the lockout condition has not been corrected, the circuit will again be forced into the LOCKOUT State.

SAFETY TRIPPED (20)

This state is entered when a safety trips but a lockout is not to be generated. An alarm is generated but the system will restart after the delay specified in the corresponding set point. If a second trip occurs within the time specified in the set point, the circuit will be placed in the CMP LOCKED OUT State.

CMP OFF/READY (5)

This state is entered when no cooling/heating capacity is required from this circuit or the prior state was CMP ANTICYCE, LOST IO LOCKED or SWITCHED OFF. In this state the circuit is ready to provide cooling capacity if needed. The circuit will remain in this state for a minimum of 60 seconds.

CMP PMP DOWN (3)

This state is entered whenever the pump down switch has been turned on or if this circuit is no longer wanted on. The compressor remains on and the liquid line solenoid is closed. This state is active until the suction pressure reaches the value in the set point 61, PMP DWN OFF or the time has exceeded the value in the set point 62, PMP DWN DELY. The circuit will then move to the ANTICYC State.

CMP ANTICYCE (4)

This state is entered when the PMP DWN State has been completed. The circuit will stay in this state with all circuit points off for the period of time contained in either set point 59 (ACYC OFF-> ON) or set point 63 (ACYC ON -> ON) whichever is longer. The circuit will then move to the OFF State. NOTE: The ACYC ON -> ON limits the number of starts per hour.

SWITCHED OFF (2)

This state is entered after the circuit has been pumped down due to the pump down switch being on or if the circuit flow switch is off. In this state the compressor, and all related points, plus the

liquid line are off. The circuit will not leave this state unless the pump down switch is turned off. If the pump down switch is turned off, the circuit-state will be changed to the OFF State.

FAST UNLOADING (14)

For screw compressors only, this state is entered when the compressor is turned on. The system will remain in this state for 60 seconds while the "fast unloader" and unload points are on. This is to ensure that the screw is unloaded.

OIL PUMP LUBING (6)

Only screw compressors with oil systems use this state. The following conditions must be meant within the time allocated in the set point LUBE DELAY or an alarm will be generated and the CMP LOCKED OUT State is entered:

1. The oil pump is started and the unload solenoid is turned on.
2. If a fast unloader is available it is turned on.
3. If a fast unloader is available, the compressor is turned on, 30 seconds later if the oil temperature is > than the LUBE OIL TMP, set point #39 and the oil pressure is > than the LUBE OIL PSI, set point #40.
4. If there is not a fast unloader, the compressor is turned on 120 seconds later if the oil temperature is > than the LUBE OIL TMP, set point #39 and the oil pressure is > than the LUBE OIL PSI, set point #40.
5. The oil heater will be turned on if needed.

When the above conditions have been satisfied, the screw compressor will be started and the state will be moved to the CMP IS HOLDING State.

UNLD1/HGBP OFF (9)

This state can only be entered for fixed step capacity compressors with a HOT GAS BYPASS solenoid. In this state the HOT GAS BYPASS solenoid is off and all unloaders in the circuit are on.

CMP IS LOADING (12)

For infinite step compressors, this state is when the load solenoid is being pulsed to increase the cooling capacity of the circuit. The duration of the pulse is specified in the set point 37, LOAD PULSE and the frequency of the pulse is determined by set point 56, PULSE DELAY. The set point PULSE DELAY should be a value of between 3 and 5 seconds. (During loading this will allow the change to take place and the amps to reflect that change.

PART LOADED (10)

This state only exists for fixed step compressors with two unloaders. This state is when the HOT GAS BYPASS solenoid, if it exists, is off, the first unloader solenoid is off and the second unloader solenoid is on.

CMP IS HOLDING (11)

This state only exists for infinite step compressors. In this state, the required refrigeration capacity of system is being meant; no movement of the slide valve is required.

CMP IS AT 40% (25)

This state is when the compressor is providing 40% of its capacity. In this state, the relay output to activate the 40% valve is turned on.

CMP IS AT 70% (26)

This state is when the compressor is providing 70% of its capacity. In this state, the relay output to activate the 70% valve is turned on.

CMP IS AT 100% (14)

For fix capacity compressors only, this state is when the compressor is fully loaded. In this state, the circuit is providing the maximum amount of cooling capacity.

CMP IS UNLDING (13)

For infinite step compressors, this state is when the unload solenoid is being pulsed to reduce the cooling capacity of the circuit by moving the slide valve. The duration of the pulse is specified in set point 38, UNLOAD PULSE and the frequency of the pulse is determined by set point 56, PULSE DELAY. The set point PULSE DELAY should be a value of between 3 and 5 seconds. (During unloading this will allow the refrigerant to enter the chamber slow enough not to cause oil foaming.

CMP UNLOADED (8)

For infinite step compressors, this state is when the slide is fully unloaded (indicated by unloaded input or after the unloader is pulsed 30 seconds with no change). For fixed step compressors, this state is when the compressor is on and fully unloaded. In this state the compressor is supplying its minimum cooling capacity.

HI DISC UNLOAD (18)

Refer to set points numbers 81, HI DISCH PSI; 82, HI DISC UNLD; 83, HI DISC RELD; 87, HI DISCH TMP; 88, HI DISCH UNLD; and 89, HI DISCH RELD.

Infinite step compressors only: The capacity is being unloaded due to a high discharge pressure or high discharge temperature. The compressor will stay in this state until the pressure or temperature has dropped below the corresponding set point. The system will then move to the HI DISC HOLD state.

HI DISC HOLD (19)

Refer to set points numbers 81, HI DISCH PSI; 82, HI DISC UNLD; 83, HI DISC RELD; 87, HI DISCH TMP; 88, HI DISCH UNLD; and 89, HI DISCH RELD.

Fixed Step Compressors -

This state is entered when a fully loaded circuit, that has more than one step, has encountered either a dangerously high discharge pressure or discharge temperature. One step of cooling capacity will be turned off. The circuit will remain in this state for a minimum of five minutes before returning to the LOADED state if the dangerous condition has been corrected.

Infinite Step Compressors -

When capacity is being held due to a high discharge condition, once the discharge goes to normal operating condition the circuit will return to its appropriate state.

HI DIS TMP HLD (24)

Refer to set points numbers 87, HI DISCH TMP; 88, HI DISCH UNLD; and 89, HI DISCH RELD.

This state is entered when a fully loaded circuit, that has more than one step, has encountered a dangerously high discharge temperature. One step of cooling capacity will be turned off. The circuit

will remain in this state for a minimum of five minutes before returning to the LOADED state if the critical condition has been corrected.

LO SUCT UNLOAD (16)

Refer to set points numbers 77, LOW SUCTION; 78, LO SUCT UNLD; and 79, LO SUCT RELD.

Infinite step compressors only: The capacity is being unloaded due to a low suction pressure. The compressor will stay in this state until the suction pressure has is above the critical value. The system will then move to the LO SUCT HOLD State.

LO SUCT HOLD (17)

Refer to set points numbers 77, LOW SUCTION; 78, LO SUCT UNLD; and 79, LO SUCT RELD.

Fixed Step Compressors -

This state is entered when a fully loaded circuit, that has more than one step, has encountered a dangerously low suction pressure. One step of cooling capacity will be turned off. The circuit will remain in this state for a minimum of five minutes before returning to the LOADED State if the dangerous condition has been corrected.

Infinite Step Compressors -

When capacity is being held due to a low suction pressure condition, once the suction pressure returns to a normal operating condition the circuit will return to its appropriate state.

LO TMP UNLOAD (21)

The circuits leaving liquid temperature has caused the system to unload. When the leaving liquid temperature gets to within 1.5 degrees F of the Freeze set point, the unload will occur before we hit the freeze protect safety.

LO TMP HOLD (22)

Reload from the 'LO TMP UNL' occurs when we are 3.0 degrees F above the freeze set point. Until we reach this point the system will remain in the LO TMP HOLD State.

HI AMP HOLD (23)

If the compressor is a **fixed** step compressor, this state is entered when a fully loaded circuit, that has more than one step, has encountered a dangerously high AMP draw. Refer to set points numbers 65 through 72 for FLA per circuit and 75 HI AMPS %. In this state, one step of cooling capacity will be turned off. The circuit will remain in this state for a minimum of five minutes before returning to the LOADED State if the dangerous condition has been corrected.

If the compressor is a **fixed** step compressor, the system enters this from the HI AMP UNLDING state. It will remain in this state for the time specified in set point #101. If the amp drawn is less than the full load amp set point for this circuit, this state will be exited and the circuit will be able to load if necessary. Note, in this state the compressor will not load but it can be unloaded if needed.

HI WATER HOLD (27)

When the compressor is running and set point #86 is active, the system will check for a high water temperature. If the control temperature is greater than the value in set point #86 for the time specified in this set point the system will place the circuit in this state. When in these state the system will be unable to continue loading.

EXTRA 70% STEP (28)

This state can only be entered if the compressor type selected is Mitsubishi Screw. This will move an extra step for this type of screw compressor.

OFF-LO OIL TMP (29)

If this state is entered, the circuit will be disabled. If the compressor type selected is either a Centrifugal or a screw compressor the oil temperature will be checked. For a Centrifugal compressor if the temperature is greater than the saturated suction temperature plus the value in set point #39 this state will be entered. For a screw compressor if the temperature is greater than the value in set point #39 this state will be entered.

HI AMP UNLDING (30)

If the compressor is an infinite step compressor this state will be entered if the amp drawn is greater than the full load amp set point for this circuit plus ½ of the value in set point #75, high amps. This is proactive to prevent a high amps safety. Once the amp drawn has been reduced the system will place this circuit in the HI AMP HOLD state.

DEF PREPMP OUT (31)

This state is only entered if the defrost type is other than NONE, Hot gas will be used to perform the defrost function. This is selected in Compressor Information section under the MAG CHL button. If there is to be defrost an alarm message will be generated and this state will be entered. The liquid line solenoid is closed, circuit will remain in this state until the suction pressure is less than the value in set point #61 or the time in this state is greater than set point #62. The circuit will then move to the DEFROSTING state.

DEFROSTING (32)

Refer to DEF PREPMP OUT state. In this state the hot gas solenoid will be opened. The circuit will remain in this state until both of the coil temperatures are greater than the value in set point #161 or the time in this state is greater than the value in set point #162. The circuit will then move to the DEF PUMP DOWN state.

DEF PUMP DOWN (33)

Refer to DEFROSTING state. In this state the hot gas solenoid will be closed. The circuit will remain in this state until the suction pressure is less than the value in set point #61 or the time in this state is greater than set point #62. The circuit will then move to the CHL_CIRCUIT_HOLDING state.

HI TEMP UNLOAD (34)

This state is only used when in Heating Mode. The system will unload if set point #152 is active and the leaving temperature is greater than the value in set point #152 minus 15.0degrees if Fahrenheit or 8.0 degrees if Celsius. In this state the circuit will unload on step. When the temperature drops below the value in set point #152 minus 30.0 degrees if Fahrenheit or 16.0 degrees if Celsius, the circuit will then move to the HI TEMP HOLD.

HI TEMP HOLD (35)

Refer to HI TEMP UNLOAD state. When the When the temperature drops below the value in set point #152 minus 45.0 degrees if Fahrenheit or 24.0 degrees if Celsius, the circuit will then return to a normal state.

SCROLL STEP 1 (36)

Only used with special patterns for TRAN Trio and Quad compressors.

If Trane Trio then COMP C is on and COMP A & B are off.

If Trane Quad then COMP A is on and COMP B, C & D are off.

SCROLL STEP 2 (37)

Only used with special patterns for TRAN Trio and Quad compressors.

If Trane Trio then COMP A & B are on and COMP C is off.

If Trane Quad then COMP C & D are on and COMP A & B are off.

SCROLL STEP 3 (38)

Only used with special patterns for TRAN Trio and Quad compressors.

If Trane Trio then COMP A, B & C are on.

If Trane Quad then COMP B, C & D are on and COMP A is off.

SCROLL STEP 4 (39)

Only used with special patterns for TRAN Quad compressors.

If Trane Quad then COMP A, B, C & D are on.

11. Condenser Control Logic

11.1. Condenser Introduction (refer to Standard Control Options Section)

Controls of common condenser, individual condensers per circuit or condensers that are shared between circuits are supported. The type of condenser plus the number of condenser points (relay outputs) are specified when building the configuration file.

In the Evaporator Information section click on the condenser type to view the types of condensers that are supported. Select the type.

The system supports the following options:

1. **No Condenser** - No condenser specified.
2. **RO Step Common** - If RO Step Common condenser is specified, the highest discharge pressure from any one of the circuits on the system will be the controlling pressure.
3. **RO Step Individual** - If RO Step Individual condenser is specified, each circuit will have one or more condenser points that are associated with that circuit. The discharge pressure on that circuit will be the controlling pressure.
4. **RO Step Combined** - If RO Step Combined condenser is specified, and then the highest discharge pressure from any one of the compressors on the shared circuits will be the controlling pressure (circuits 1&2 are shared; circuits 3&4 are shared, circuits 5&6 are shared, and circuits 7&8 are shared).
5. **Modulating Common** - If Modulating Common condenser is specified, the highest discharge pressure from any one of the circuits on the system will be the controlling pressure. A change to the modulating analog output position is calculated every 30 seconds based on the Rate of Change of the controlling discharge pressure.
6. **RO Shared** - Similar to RO Step Individual but two circuits: circuit 1 & 2 will share circuit one's fan and then 2 & 3 will share circuit two's fan.
7. **Dual V8**
8. **Modulating Individual** - If Modulating Individual condenser is specified, each circuit will have one or more condenser points that are associated with that circuit. A change to the modulating analog output position is calculated every 30 seconds based on the Rate of Change of the controlling discharge pressure.
9. **Mod Common w/Bypass** - If Mod Common w/Bypass is selected three consecutive relay outputs, analog output, and a VFD fault indicator are required to control this type of condenser fans.
 - 1) VFD LOAD This relay will be on indicating that the fan can be used.
 - 2) VFD BYPS This will be off unless a fault with the VFD has occurred.
 - 3) VFD ENAB This relay will be on unless the VFD fault has occurred.

Normal operation, the VFD LOAD will be on, the VD BYPS will be off and the VFD ENAB will be on. The fan will be modulated as required by the condenser logic or the economizer logic.

If a fault occurs, all relays will be turned off and the VFD will be set to 0. The system will wait for the time specified in set point #90. This is a time delay before the fan will be run with out VFD control if it is needed by the condenser logic. Note, it will not be used by economizer logic in this condition. Once this time has passed and the condenser logic needs the fan, the VD BYPS will be turned on thus turning the fan on. This will NOT be modulated, once on it will stay on.

The system will also support a variable speed fan for all three of the air type of condensers. Each circuit can support a variable speed fan. The variable speed must be on the first condenser point associated with that circuit.

11.2. RO Step Condenser Cut In – Out Logic

The air condenser set points are as follows:

Set point 45 CND STG1 ON	- Condenser stage 1 cut in (ON).
Set point 46 CND STG1 OFF	- Condenser stage 1 cut out (OFF).
Set point 47 CND DIFF ON	- Differential between condenser stages for cut in (ON).
Set point 48 CND DIFF OFF	- Differential between condenser stages for cut out (OFF).
Set point 49 CND MIN RUN	- Minimum run time for a condenser stage

Condenser points, (i.e. pumps and or fans), will be turned on based upon the value in set point (COND ST1 ON) #45, when the discharge pressure reaches this value the first condenser point is turned on. If additional condenser points exist, they will be turned on when the pressure exceeds the previous cut in value plus the value contained in (COND DIFF ON #47) set point. As the discharge pressure is reduced, the condenser points will be turned off based upon the set point (COND ST1 OFF #46) value plus the condenser step times the value contained in (COND DIFF OUT #48) set point. The first step will be turned off based upon the value in the set point (COND ST1 OFF).

Example	Set point 45 CND STG1 ON	= 200.0P
	Set point 46 CND STG1 OFF	= 170.0P
	Set point 47 CND DIFF ON	= 20.0P
	Set point 48 CND DIFF OFF	= 5.0P

COND FAN1 ON @ 200.0P DISCHARGE
COND FAN 1 OFF @ 170.0 P

COND FAN2 ON @ 220.0p (200.0 + 20.0)
COND FAN2 OFF @ 175.0p (175.0 + 5.0)

COND FAN3 ON @ 240.0p (220.0 + 20.0)
COND FAN3 OFF @ 180.0p (170.0 + 10.0), etc.

11.3. RO Step Condenser With Variable Speed Fan

The set points for air condensers with for variable speed fan control are as follows:

Set point 54 CND MIN SPD	- Minimum variable speed allowed.
Set point 55 CND MAX SPD	- Maximum variable speed allowed.

The purpose of the variable speed fan is to reduce the cycling of the fans by adjusting the speed of the variable fan point. This control works in conjunction with the cut in and cut out logic of each circuit. The cut in and cut out logic turns on or off the various condenser fan points. When a fan is turned on, the speed of the variable point for that circuit is set to maximum allowed percentage. As the discharge PSI lowers the fan speed is adjusted proportionally. When the minimum is reached a fan is turned off.

Once a fan point has been turned on, the system will vary the fan speed for that circuit. This will be based upon where the discharge pressure is in relationship to turning the current fan point off and turning the next fan point on.

11.4. Modulating Condenser

The example is of a system with a water condenser. The water valve will be modulated.

The water condenser set points are as follows:

Set point	50 CND VLV TARG	- Discharge target pressure
Set point	51 CND VLV DIV	- Condenser valve adjustment sensitivity
Set point	52 CND VLV MIN	- Condenser valve minimum opening
Set point	53 CND VLV ROC-	- Condenser max negative Rate of Change
Set point	54 CND MIN SPD	- Minimum speed for the variable speed condenser fan
Set point	55 CND MAX SPD	- Maximum speed for the variable speed condenser fan

Condenser water valve will be adjusted based upon the Rate of Change of the discharge pressure. The logic is setup to modulate a water valve using the analog output (0 to 10vdc), to maintain the discharge pressure (logic selects the highest discharge pressure from the running circuits).

Example	CND VLV TARG	=	190.0P
	CND VLV DIV	=	1
	CND VLV MIN	=	25%
	CND VLV ROC-	=	-5.0P
	CND MIN SPD	=	25%
	CND MAX SPD	=	100%

11.5. Condenser Fan Bank

The purpose of the fan bank is to indicate compressors that share condenser fans. During the first five minutes after a compressor is started if its discharge pressure is less than set point #44, condenser cut in, and set point #46, condenser differential, the discharge pressure of this compressor will be used to determine when fans will be turned on. This will allow head pressure to be built for the starting compressor.

The fan bank number is specified in the **MCS-Config** program in the circuit grid. If not used the fan bank number must be the same as the circuit number.

12. Set point Definitions

12.1. Set point elements that can be viewed:

- 1) Number - the number is from 1 to 170, maximum number of set points that are supported. Only active set points will be displayed. (Active set points can be displayed as a function of Authorization)
- 2) Name - the set point's name consists of up to 12 alphanumeric characters. The name is displayed following the number on the first line of the LCD display. The name of the set point can be changed to make it meaningful to the given application. **HOWEVER** the function of the set point will remain the same.
- 3) Value - this is the value or target of a set point. With the proper authorization this value can be changed within limits that have been established by the **MCS-Config** program.
- 4) Time – this field has two purposes: 1) in either a LOCKOUT or ALARM type; this is the time that the set point must be true before it will trip. E.g. a high discharge safety must have its value exceeded for this length of time before it will trip. This time is always in seconds and it is displayed on the LCD and also via the MCS-Connect program if the set point is either a LOCKOUT or ALARM type. This field can be changed via MCS-Connect, **MCS-Config** or through the keypad. In a non safety type set point this field can be used as any extra timer. This will be specified in the set point definition if it is used.
- 5) Type - the type indicates the action that will be taken.

A list of set points and all their elements can be obtained from the **MCS-Config** program.

12.2. Set point Types:

There are three different types of set points. The Magnum software determines if a set point contains a target value or if it is a safety. If it is a safety then the type determines the action that the system will take when the safety occurs. That is either a lockout or alarm only if the safety trips.

12.2.1. SET POINT

This type of set point's value contains a target or provides information for some type of action. The time element in this type can be used for an additional counter if specified. This time is displayed and can be changed via MCS-CONNECT, MCS-CONFIG or from the display..

12.2.2. LOCKOUT

This type of set point's value contains a safety level and the time that the safety must be violated before the safety will trip. Once a safety has tripped the system will take the appropriate action, shutting down the entire package or an individual circuit (compressor) depending on the purpose of the safety. The system will then wait the safety down time contained in that set point before trying to return the system to normal. If successful, the system will continue to operate. If a second trip occurs on the same set point within the lock out delay time that is contained in that set point the system will move to a LOCKOUT state. **IF THE LOCKOUT DELAY TIME IS SET TO ZERO THE LOCKOUT WILL OCCUR ON THE FIRST TRIP.** This will require manual intervention to reset the system. With each safety trip, the system will generate an alarm; refer to Alarms and Safeties section of this manual.

The safety down time and the lock out delay time are unique for each set point. They cannot be viewed in a live unit. They are set in the **MCS-Config** program.

12.2.3. ALARM

This type of set point has two purposes:

- 1) When it is used as a safety. It will be similar to the LOCKOUT set point except it will never cause a lock out. The system will continue to try to return to normal operation after waiting the safety down time. An ALARM set point type will never require manual intervention to reset the system.
- 2) When the set point is a non safety type but its time field is being used as a second timer and it will be

made available to be changed in the live unit. If the type is not changed to ALARM then the time field can not viewed or changed from a live unit.

13. Set points for Magnum Chiller V8 Algorithm (BY Category)

13.1. Control Set points

1	CTL TARGET	Control target. This value will be used to develop the Control Zone, refer to set points # 2 & #3. The control target is used with the control zone & rate of change of the controlling sensor to determine required action. The controlling sensor is usually one of the following: Leaving liquid – usually this is the target. Return liquid - Used with large masses, ice rinks, common areas, etc Suction PSI - Continuous running process systems
2	CTL ZONE +	Added to the CTL TARGET to create the top of the control zone.
3	CTL ZONE -	Subtracted from the CTL TARGET to create the bottom of the control zone.
4	HGS TEMP ON	This set point is used with screw compressors that have a hot gas by pass solenoid. When this set point is active and the control temperature is less than the CTL TARGET plus this value and the FLA % is within 25% of the MIN SLIDE% (set point #31), the hot gas by pass solenoid for the compressor on this circuit will be turned on.
5	HGS TEMP OFF	This set point is used with screw compressors that have a hot gas by pass solenoid. When this set point is active and the control temperature is greater than the CTL TARGET plus this value or the FLA % is not within 25% of the MIN SLIDE% (set point #31), the hot gas by pass solenoid for the compressor on this circuit will be turned off.
6	HGS PSI ON	This set point is used with screw compressors that have a hot gas by pass solenoid. When this set point is active and the suction pressure is less than this value and the FLA % is within 25% of the MIN SLIDE% (set point #31), the hot gas by pass solenoid for the compressor on this circuit will be turned on.
7	HGS PSI OFF	This set point is used with screw compressors that have a hot gas by pass solenoid. When this set point is active and the suction pressure is greater than this value or the FLA % is not within 25% of the MIN SLIDE% (set point #31), the hot gas by pass solenoid for the compressor on this circuit will be turned off.
8	L.INJECT.ON	Liquid injection is turned on when the discharge temperature is equal to or greater than this set point and turned off when the discharge temperature is less than this set point minus 10.0°F (or 5.5°C).
21	MAX TRG RESET	This value is used to adjust the control CHL OUT TARG set point #1. The sensor input value will vary between 0 and 5 volts and the actual adjustment will be proportion from negative MAX TRG RESET value to positive MAX TRG RESET value.
22	LOW AMBIENT	If the ambient temperature is below this value the package will be disabled, unit state will be AMBIENT OFF. Once off on low ambient the unit will remain off until the ambient rises above this set point value by 5.0F (or 2.5C).
23	POWERUP DELAY	This is the time that the system will remain in the START UP state before moving to the next state.
24	HI AMBIENT	If the ambient temperature is above this value the package will be disabled, unit state will be AMBIENT OFF. Once off on high ambient the unit will remain off until the ambient drops below this set point value by 5.0F (or 2.5C).
134	BARREL HEATER	Set point at which barrel heater will be turned on when ambient drops below.
135	REFRIG LEAK	A digital signal from a refrigerant leak detector

13.2. EXV Control Set Points

9	SPRHT TARGET	This is the target for SUPERHEAT that the system will maintain. This value can be dynamically changed, see set point # 110.
10	SPRHT ZONE +/-	This set point, plus or minus the SPRHT TARGET, defines the width of each control zone. (opening/closing, 2x or 4x
11	EXV LOAD ADJ	EXV adjustment made in response to a load or unload slide adjustment
12	EXV FINE ADJ	The adjustment made when in the 1 st zone above or below the control zone.
13	EXV COURSE	This adjustment made when in the 2 nd zone above or below the control zone and the adjustments are made in 1/2 the time. This adjustment made when above or below the 2 nd control zone and the adjustments are made in 1/4 the time.
14	EXV LOAD DIV	As the amp % changes this divides the EXV % change. Calculate as follows: $(\text{Max slide\%} - \text{min slide\%} / \text{Max vlv\%} - \text{min vlv\%}) + 1$
15	EXV MIN %	This is the minimum valve position allowed when modulating the expansion valve. The calculated position is not allowed to be less then this set point. This value should be set so when hot gas is applied the valve opening is adequate.
16	EXV MAX %	This is the maximum position allowed when modulating the expansion valve to maintain the SUPERHEAT target. This value should be the valve% opening at 100% capacity + 10 to 15 %.
17	LO SUPERHEAT	If the calculated SUPERHEAT remains below this value for the time specified, the system will place the associated value in the LOW SPR STATE and generate LOW SUPERHT alarm.
18	LOWSUCPSI DLY	Delay in seconds when in Low Suction PSI Opening
19	EXV DELAY	Delay in seconds between valve adjustments. Should not be less than 48. (When adjusting at 4x this will allow 12 seconds to see the result before making the next adjustment.
20	EXV STRT TIME	This is a time (in seconds) to hold the valve at the start % set point when the compressor starts. Since the SUPERHEAT calculation is not valid when the compressor is not running the EXV logic sets the valve to a giving position for a given time in order to allow the system to run and develop a valid SUPERHEAT temperature. This set point contains the given time to hold the valve at the given opening. (See set points #113 to #120 for the time).
113 To 120	SPARE	These used to be the starting % EXV valve opening. To expand the Magnum from 8 circuits these were moved to the RO area in the Cfg

13.3. Capacity Control Set Points

25	STEP SENSTIY	This value is used to adjust the speed of responding to changes in the control algorithm. 1= faster response HIGHER number's = slower response. Used only with the MAGNUM Control Zone control method.
26	STEP DELAY	Both the value and safety time fields can be used. Value: This is the time delay before increasing or decreasing the number of refrigeration steps. Used only with the MAGNUM Control Zone control method. Safety Time Field: If used, this will force a minimum time delay between two compressor starts.
27	MAX ROC -	Maximum negative Rate Of Change allowed before stopping the unit from loading. If the actual ROC is less than this value the capacity control state is placed in the HOLDING state. Used only with the MAGNUM Control Zone control method.

28	MAX ROC +	Maximum positive Rate Of Change allowed before stopping the unit from unloading. If the actual ROC is greater than this value the capacity control state is placed in the HOLDING state. Used only with the MAGNUM Control Zone control method.
29	ROC INTERV	Number of second between the samples used for calculating the actual Rate Of Change. Used only with the MAGNUM Control Zone control method. Maximum 60 seconds

13.4. Control for Variable Step Compressors Set Points

30	MAX SLIDE %	Indicates the maximum slide or speed allowed. If speed limit it is usually set to 100%. In variable step control, it limits the slide load until all compressors are on or the number on is greater than set point #102, STEP CMP LIM, then they will all loaded to 100% of FLA.
31	MIN SLIDE %	Both the value and safety time fields can be used. Value: Indicates the minimum slide or speed allowed. Usually 40%. This is where the slide valve or the inverter will be set when the compressor is turned on. This % is a function of current amp draw relative to current FLA. Safety Time Field: If used, this will force a time delay before unloading all running compressors before the next compressor is started.
32	MAX ADJUST %	Indicates the maximum percentage change that can be made to the slide valve or the inverter when more cooling capability is needed.
33	MIN ADJUST %	Indicates the minimum percentage change that can be made to the slide valve or the inverter when less cooling capability is needed.
34	SLIDE SENSITY	This allows control of the adjustment made to slide wanted percentage. The adjustment is relative to the difference between current leaving liquid temperature and target. The larger the value the larger the adjustment. (Almost always a 1 but should not be greater than 3.)
35	AMP DB HI	This set point is only used in the screw compressors. This value is the upper dead band limit to stop pulsing the slide valve. If the actual amps are within the dead band, the slide valve will not be moved.
36	AMP DB LO	This value is the lower dead band limit to stop pulsing the slide valve. If the actual amps are within the dead band, the slide valve will not be moved.
37	LOAD PULSE	Length of time to turn on the slide valve load solenoid. Time is expressed in 1/10 of a second. (This value should be between 1 & 9.)
38	UNLOAD PULSE	Length of time to turn on the slide valve unloader solenoid. Time is expressed in 1/10 of a second. . (This value should be between 1 & 9.)
39	LUBE OIL TMP	Used only with screw compressors with oil, the oil must reach this temperature before the system will move out of the LUBE state.
40	LUBE OIL PSI	Used only with screw compressors with oil, the oil must reach this pressure before the system will move out of the LUBE state.
41	LUBE DELAY	Used only with screw compressors with oil, this is the maximum time that a compressor can be in the LUBE state. When this time is exceeded, an alarm is generated and the circuit is placed in a lockout state. Both the oil temperature and pressure must be satisfied before the LUBE state will be exited.

56	PULSE DELAY	Both the value and safety time fields can be used. Value: Used with infinite capacity screws. The number of seconds between load or unload pulses. (Should be between 3 & 5. Allows load change to be checked before next pulse. Eliminates oil foaming when unloading too fast.) Safety Time Field: If used, this is the fast unloading state time delay (previous was a fixed value now it is adjustable).
136	VI PULSE	Used with an adjustable VI, volume ratio. This is the pulse time expressed in tenths of second to move the VI.
137	VI DEADBAND	Used with an adjustable VI, volume ratio. If the VI reading is greater than the vi wanted ratio plus the value of this set point then the increase RO is off and the decrease RO is pulsed. . If the VI reading is less than the vi wanted ratio minus the value of this set point then the increase RO is pulsed and the decrease RO is off.
138	VI DELAY	Used with an adjustable VI, this is the time delay between calculating a vi wanted ratio.
143	UNLOADED %	Used if a slide percentage open sensor exists, when this sensor 's value is less than the value of this set point the slide is considered closed.
144	OIL HEATER ON	This set point is used with a compressor that has an oil heater. The oil heater is turned on if the oil temperature is less than the value of this set point. It will be turned off if the oil temperature is greater than the value of this set point plus 5.0 degrees Fahrenheit.
145	OIL COOLER ON	This set point is used with a compressor that has an oil cooler. The oil cooler is turned on if the oil seal temperature is greater than the value of this set point. It will be turned off if the oil seal temperature is less than the value of this set point minus 5.0 degrees Fahrenheit.
151	UNLOADED OFF	When this set point is active and the system is fully unloaded with only one step on and the control temperature is greater than this value the capacity state will be set to holding.

13.5. Condenser Control Set points

45	CND STG1 ON	Air cooled- When the discharge pressure is above this value; turn on the first stage of the condenser fans.
46	CND STG1 OFF	Air cooled- If stage 1 is on and the discharge pressure drops below this value turn off the first stage of condenser fans.
47	CND DIFF ON	Air cooled- Differential PSI to turn on the remaining stages of condenser fans.
48	CND DIFF OFF	Air cooled- Differential PSI to turn off the remaining stages of condenser fans.
48	DUAL PSI DELTA	Dual V8 – Difference in pressure before stage 2 can be entered.
49	CND MIN RUN	Air cooled- Once a condenser fan stage has been turned on; it will remain on for at least the amount of minutes specified in this set point.
49	DUAL TIME DELAY	Dual V8 – Time delay once the pressure difference as been reached before stage 2 can be entered.
50	CND VLV TARG	Water cooled- Target discharge pressure to maintain by integration and Rate of Change logic.
51	CND VLV DIV	Water cooled- Usually 1. Allows control of the amount the valve is adjusted. The larger the number the smaller the valve adjustment.
52	CND VLV MIN	Water cooled- Minimum valve opening percentage allowed.

53	CND VLV ROC-	Water cooled- Maximum negative discharge pressure Rate of Change allowed. If the actual rate of change is less then this set point then stop opening the valve. The absolute value of this set point also severs as the maximum positive rate of change allowed. If the actual rate of changes is greater than the absolute value of this set point then stop closing the valve.
57	LO AMB PROC	When this set point is active and there is a process pump, when the ambient temperature is less than the value of this set point the process pump will be turned on. The process pump will be turned off when the ambient temperature is greater than the value of this set point 5.0 degrees Fahrenheit.

13.6. System Testing Set Points

58	CFG TESTING	This MUST be setup as 'Not Used' or be set to '1', in a configuration running in the field, or the micro will not stop when an I/O communications signal is lost.
----	-------------	--

13.7. Compressor Control Set Points

59	ACYC OFF->ON	This is the anti cycle time delay (in seconds) based on when the compressor was turned off. This value is used in a calculation to determine how long a compressor should be in the anti-cycle state. Refer to the Standard Control Options section, Compressor Anti-Cycle Logic. (OFF to ON)
60	SPARE 60	
61	PMP DWN OFF	This is the suction pressure value for turning off the compressor when in the PUMP DOWN state.
62	PMP DWN DELY	Maximum time delay (in seconds) that a compressor can remain in the PUMP DOWN state.
63	ACYC ON->ON	This is the anti cycle time delay (in seconds) based on when the compressor was turned on. This value is used in a calculation to determine how long a compressor should be in the anti-cycle state. Refer to the Standard Control Options section, Compressor Anti-Cycle Logic. (ON to ON)
64	COMP MIN RUN	This is the minimum run time (in minutes) for a compressor once it is turned on. This minimum run time is bypass only for the safeties.
65	FLA COMP#1	Full Load Amps for the compressor on circuit 1. For screw compressors, the ampere when the compressor is fully loaded. This value is used to calculate the compressor current FLA %, which is used to control the loading and unloading of the slide valve. This value is used to calculate the high and the low ampere safeties limits. Refer to set points 75 and 76. Note: This is the amps at design suction & head referenced in config RO screen.
66	FLA COMP#2	Full Load Amps for the compressor on circuit 2. Refer in set point 65 for definition.
67	FLA COMP#3	Full Load Amps for the compressor on circuit 3. Refer in set point 65 for definition.
68	FLA COMP#4	Full Load Amps for the compressor on circuit 4. Refer in set point 65 for definition.
69	FLA COMP#5	Full Load Amps for the compressor on circuit 5. Refer in set point 65 for definition.
70	FLA COMP#6	Full Load Amps for the compressor on circuit 6. Refer in set point 65 for definition.

71	FLA COMP#7	Full Load Amps for the compressor on circuit 7. Refer in set point 65 for definition.
72	FLA COMP#8	Full Load Amps for the compressor on circuit 8. Refer in set point 65 for definition.
73	STARTER DLAY	Time delay (in seconds) between the first and second relay being turned on. Used for part wind (typical value of 1) and star delta (typical value of 5) starter.
74	OIL PUMP OFF	If oil pump is always on (specified in the MCS-Config program), this set point is not used. If oil pump is not always on then this set point contains the PSI value when the oil pump is to be turned off.

13.8. Compressor Safeties Set Points

75	HI AMPS	This set point is a percentage of the FLA; it is used to create the high amp draw limit. Depending on the circuit that is being tested: the value of this set point is multiplied by either the value in set points 65 through 72 to obtain the circuit's high limit. This value is tested in the high amp safety, if the amps exceed this value for the time specified in this set point the safety is tripped.
76	LO AMPS	This set point is a percentage of the FLA; it is used to create the low amp draw limit. Depending on the circuit that is being tested: the value of this set point is multiplied by either the value in set points 65 through 72 to obtain the circuit's low limit. This value is tested in the low amp draw safety, if the amps are below this value for the time specified in this set point the safety is tripped.
77	LOW SUCTION	If active, the system checks for low suction pressure for each running compressor. The system will compare the suction pressure sensor reading to this value. It must be less than the value for the period of time specified in the set point before this set point will trip. <u>Digital or analog – Refers to 'Suction Pressure' column under circuits under Chiller V8 tab of MAG-Config</u>
78	LO SUCT UNLD	The purpose of this set point is to take corrective action before a low suction pressure safety occurs. If a circuit has more than one step and it is fully loaded and if the suction pressure is less than the value of the safety set point (LOW SUCTION) plus the value of this set point, the system will turn off one step of capacity. An infinite step compressor will be forced to unload until the suction pressure rise above the calculated value. The circuit state will be changed to LO SUCT HOLD. The circuit will remain in this state for a minimum of 5 minutes. At that time, if the suction pressure has increased to a level greater than the value of set point LOW SUCTION plus the value of set point LOW SUCT RELD the compressor will return to normal control.
79	LOW SUCT RELD	See set point 78 description
80	UNSAFE SUCT	If active, the system checks for low suction pressure that is in an unsafe condition for each running compressor. The system will compare the suction pressure sensor reading to this value. It must be less than the value for the period of time specified in the set point before this set point will trip. Note the time period specified should be very short, 2-5 seconds. This safety set point trips the circuit to the LOCKOUT state immediately, no retry.

81	HI DISCH PSI	<p>If active, the system checks for high discharge pressure condition for each running compressor. The system will compare the discharge pressure sensor reading to this value. It must be greater for the period of time specified in the set point before this safety will trip.</p> <p><u>Digital or analog – Refers to ‘Discharge Pressure’ column under circuits under Chiller V8 tab of MAG-Config</u></p>
82	HI DISC UNLD	<p>The purpose of this set point is to take corrective action before a high discharge pressure safety occurs. If a circuit has more than one step and it is fully loaded and its discharge pressure exceeds the value of the safety set point HI DISCH PSI (set point 81) minus this set point, the system will turn off one step of capacity. A screw compressor will be forced to unload until the discharge pressure falls below the calculated value. The circuit state will be changed to HI DISC HLD. The circuit will remain in this state for a minimum of 5 minutes. At that time if the discharge pressure has dropped below the value of the HI DISCH PSI minus the HI DISC RELD (set point 83) the compressor will return to normal control.</p>
83	HI DISC RELD	<p>This set point works in conjunction with set point 82. Refer to that set points description.</p>
84	LO DISC SHEAT	<p>This set point contains the value that indicates a low discharge SUPERHEAT condition. If the calculated discharge SUPERHEAT is less than this value, the low discharge SUPERHEAT timer will be set to 120 seconds. This will keep the low discharge SUPERHEAT RO on for that period of time. (This can be used as a warning only or the user may wire through the low discharge superheat relay to solve the problem.)</p>
85	LO DISC PSI	<p>If active, the system checks for low discharge pressure. The system will compare the sensor reading to this value. It must be less than the value for the period of time specified in the set point before a safety trip occurs.</p>
86	HI RETURN TEMP	<p>If active the system will check for high temperature of the entering liquid. If this temperature is greater than the value in this set point, the system will move the circuit's state to HI WATER HOLD. This is similar to other holding states.</p>
87	HI DISCH TMP	<p>If active, the system checks for high discharge temperature condition for each circuit that has at least one step on. The system will compare the discharge temperature sensor reading to this value. It must be greater for the period of time specified in the set point before this safety will trip.</p> <p><u>Digital or analog – Refers to ‘Suction Temperature column under circuits under Chiller V8 tab of MAG-Config</u></p>
88	HDISCT UNLD	<p>The purpose of this set point is to take corrective action before a high discharge temperature safety occurs. If a circuit has more than one step and it is fully loaded and its discharge temperature exceeds the value of the safety set point HI DISCH TMP (set point 87) minus this set point, the system will turn off one step of capacity. A screw compressor will be force to unload until the discharge temperature falls below the calculated value. The circuit state will be changed to HI DISC HLD. The circuit will remain in this state for a minimum of 5 minutes. At that time if the discharge temperature has dropped below the value of the HI DISCH TMP minus the HI DISC RELD (set point 89) the compressor will return to normal control.</p>
89	HDISC T RELD	<p>This set point works in conjunction with set point 88. Refer to that set points description.</p>
90	COND FAULT	<p>This set point is used to determine the action when a system has condensers with fault indicators and one indicates a fault.</p> <p>If this set point is active and a condenser fault occurs, a set point alarm message will be generated. If this set point type is LOCKOUT then all of the circuits associated with this fault will be locked off.</p>

91	LOW OIL DIF	<p>If active, the system checks for low differential oil pressure. The system will compare the calculated differential oil pressure to this value. It must be less than the value for the period of time specified in the set point before the safety will trip.</p> <p><u>Digital or analog – Refers to ‘Oil Pressure’ column under circuits under Chiller V8 tab of MAG-Config</u></p>
92	UNSAFE OIL	<p>If active, the system checks for low differential oil pressure. The system will compare the calculated differential oil pressure to this value. It must be less than the value for the period of time specified in the set point before the safety will trip. The time delay for this set point should be very short 2-5 seconds. This safety trips to a lockout no retries are attempted. Manual intervention is required.</p>
93	HI OIL SEAL	<p>Only used with a screw or centrifugal compressor. If the oil seal / or oil cooler temperature exceeds the value of this set point the system for the time specified, this safety will trip.</p>
94	HI OIL TEMP	<p>If active, the system checks for high oil temperature. The system will compare the oil temperature sensor reading to this value. It must be ON or greater for the period of time specified in the set point before this set point will trip. The sensor can be either an analog or digital input.</p> <p><u>Digital or analog – Refers to ‘Oil Temp’ column under circuits under Chiller Chiller V8 tab of MAG-Config</u></p>
95	MOTOR FAULT	<p>If active, the system checks for high motor temperature. This can be either a digital input or an analog input, the system will compare the sensor reading to this value. It must be ON or greater for the period of time specified in the set point before this set point will trip.</p> <p><u>Digital or analog – Refers to ‘Motor Temp’ column under circuits under Chiller V8 tab of MAG-Config</u></p>
96	NO CMP PROOF	<p>If this set point is active and there is a digital input indicated for compressor proof, when the compressor is on, the compressor proof will be checked for that circuit.</p>
97	DIRTY FILTER	<p>Only used for screw compressors. If the discharge pressure minus the oil filter pressure is greater than this value for the time specified a safety trip would occur.</p>
98	LLS#2 ON	<p>The value, safety time and delay between trips fields can be used. This set point is used to control a 2nd liquid line solenoid. Value: When the chiller capacity wanted is greater then this value for number of seconds contained in the Safety Time Field the 2nd liquid line solenoid will open. When the circuit capacity is below the value in Delay Between Trips Field the value will be turned off. Safety Time Field: This field contains a forced delay before the solenoid will be turned on. If it is zero then there will be no delay. Delay Between Trips Field: This field contains the cut off offset for turning this solenoid off. If it is zero then an offset of 20 will be used.</p>
99	LLS#3 ON	<p>The value, safety time and delay between trips fields can be used. This set point is used to control a 3rd liquid line solenoid. Value: When the chiller capacity wanted is greater then this value for number of seconds contained in the Safety Time Field the 3rd liquid line solenoid will open. When the circuit capacity is below the value in Delay Between Trips Field the value will be turned off. Safety Time Field: This field contains a forced delay before the solenoid will be turned on. If it is zero then there will be no delay. Delay Between Trips Field: This field contains the cut off offset for turning this solenoid off. If it is zero then an offset of 20 will be used.</p>

100	LO REFR UNLD	If the refrigerant temperature drops below this value, the circuit will unload in an attempt to prevent the low refrigerant temperature safety from occurring. This is only active in software CHL C.
101	SFTYHOLD DLY	Time in seconds to hold before trying to reload when the capacity has been decreased to avoid a safety, (Examples: high disc PSI, high disc temp, low suct PSI, etc.)
102	Spare 102	
103	LEAD COMP	Enables the user to specify the lead compressor. If a value is less than the maximum number of compressor the lead indicator is set to this value. If the value is zero then auto rotation is enabled.
104	COMP ROTATION	Specifies the number of days between rotation (set point #103 must be set to zero to enable auto rotation). If the value is zero then rotation will occur with every capacity cycle.
128	PRTWIND FAIL	If aux contact available this set point allows detection of a part wind failure
139	OIL FLOAT	If active, the system checks for low oil. The system will check the oil float digital input. It must be ON for the period of time specified in the set point before this set point will trip.

13.9. Chilled Water Pump Control Set Points

105	PUMP FAILURE (NO FLOW)	If active and flow is lost and only one pump is present the system will move to a LOCK OUT state. If the system has two pumps and flow is lost the backup pump will start and the lead pump will be locked out. If the second pump is running and flow is lost then the entire system will be locked out. A lock out reset will be required to restart the system or to reactive a locked out pump. If inactive and the flow is lost, the system will move to the OFF- NO EVAP FLOW state. When flow is returned the system will automatically restart, no reset is required. This set point had been referred to as the NO FLOW.
106	LEAD PUMP	Enables the user to specify the lead pump.
108	PUMP DELAY	Time delay in seconds to keep the chilled water pump running after the last compressor has been turned off. This will help insure that a chiller barrel does not freeze up.
109	HiRefLevel	This set point has two functions. If active, the system checks for high refrigeration level. The system will compare the sensor reading of the refrigeration level sensor to this value. It must be greater than the value for the period of time specified in the set point before a safety trip occurs. If active, and the system has EXV values, if the superheat for a circuit is greater than this value the EXV valve adjustment will be set to the value in set point #13, EXV COURSE, times -3.
110	LoRefLvlTarg	If the low super heat safety timer has reached one third of the safety time in set point #84, LO DiscSPRHT and it is active then set point #9, REF LVL TARG value will be set to the value of this set point,

13.10. Unit Safeties Set points

111	FREEZE	If active, the system checks for freeze protection. The system will compare the chilled water out temperature to this value. It must be less than the value for the period of time specified in the set point before this safety will trip.
112	NO STOP	This set point is used to insure that a compressor is actually off when the system has called for it to be off. The value of the set point contains a percentage of the FLA COMP set points 65-72. If the compressor ampere is greater than this percentage of the FLA set point for the period specified the compressor is still running and the entire unit is locked out and a NO STOP alarm is generated. If a Control power relay is setup then it will be turned off when this safety trips.

13.11. Reversed Set Points for User Defined Functions

113 To 114	Reversed	Can be used by the user defined functions.
------------------	----------	--

13.12. Outside Air Economizer (Fluid Cooler) Set Points

107	EcoDelayMech	Value in seconds is the delay after the economizer is fully loaded, valve opened to its maximum and all associated fans are on, before the mechanical cooling is enabled. . If this set point is inactive then the value of set point #125 will be used for this delay.
115	EcoVFDfanDely	If the fluid cooler has a condenser VFD fan associated with it, this set point will be the time delay in seconds between adjustments to the VFD. If this set point is inactive then the value of set point #124 will be used for this delay timer.
119	EcoOffsetON	Temperature off set used to determine if the economizer function could be started. The ambient temperature must be less than target temperature minus the value of this set point. For example if the target is 45.0F and this value is 10.0F then the ambient temperature must be less than 35.0F to enable the economizer to begin.
120	Eco Stg Dely	Once the economizer valve has been opened to its maximum and all fans associated only with the economizer if any have been turned on; the economizer function will wait this time, expressed in seconds, before the first condenser fan is turned on or if a VFD it will be set to its minimum position. The minimum setting of the VFD is the value of set point #54.
121	Eco MIN VLV%	Economizer minimum Analog Output valve %. When the economizer function begins the valve is opened to this value. When closing the valve this will be the minimum setting. This set point must be active to indicate that the Economizer AO option is active.
122	Eco MAX VLV%	Economizer maximum Analog Output valve %. This is the maximum that the valve can be opened.
123	Eco MAX ADJ	Economizer maximum adjustment to the Analog Output valve % with each calculation. Example: $\{abs(Target - current) * Multiplier\} / Divisor$
124	EcoVlvAdjDly	Economizer delay between output valve adjustments.

125	Eco StageDly	Time delay once the valve has been opened to its maximum and turning on the associated condenser fans.
126	Eco MULTI	Economizer multiplier to scale adjustment to Analog Output valve %. The difference between the control temperature and its target will be multiplied by this value.
127	Eco DIVIDE	Economizer divisor to scale adjustment Analog Output valve %. The difference between the control temperature and its target will be divided by this value.

13.13. Spit Winding Set Points

128	Lost Leg Alm	If active, check for lost leg on split winding.
-----	--------------	---

13.14. Reheat (Relative Humidity) Set Points

129	RH CUTIN	Reheat cut in temperature
130	RH CUTOFF ADJ	Reheat cutout temperature is developed by adding this value to set point #129
131	RH START DLY	Reheat delay in seconds before starting
132	RH BLEED DLY	Reheat delay in seconds before starting bleeding of gas
133	RH STAGE DLY	Reheat delay in seconds before starting next stage of reheat

13.15. Blower Control Set Points

146	BLOWER TARG	Blower static pressure target
147	BLOWER ZONE	Blower static pressure \pm control zone
148	BLOWER DELY	Blower delay, in seconds, before next change.
149	BLWR MAX ROC	Blower slope, rate of change. If the slope exceeds this value no change is required.
150	BLWR MIN SPD%	Blower minimum speed.

13.16. Defrost Control Set Points

158	DEF TRIG TMP	If a defrost option has been specified and either coil #1 or coil #2 temperature if they exist is less than or equal to the value of this set point a defrost cycle will be started if sufficient time has elapsed since the last defrost.
159	DEF TRIG DEL	This set point contains the time expressed in minutes between defrost cycles.
160	DEF REV DEL	If there is a reversing valve, this is the delay expressed in minutes that the system must wait once the valve has been turned on before the defrost cycle can continue.
161	DEF TERM TMP	Once a defrost cycle begins it can be terminated when both coil #1 and coil #2 temperature if they exist are greater than the value of this set point.
162	DEF TERM DEL	Once a defrost cycle begins it will be terminated when the time this value expressed in minutes.

13.17. Heat Pump Control Set Points

152	HP OVERHEAT	This set point is only used when the heat pump option has been selected. This set point is to protect against overheating of a heat pump with unloaders or variable speed. When this set point is active and there is a leaving temperature sensor and it valve is greater than this set point minus 3.0 degrees Fahrenheit the circuit will enter the high temp unload state. The temperature must drop to less than this set point minus 4.5 degrees Fahrenheit before the system will move to the holding state.
157	HP LoSuctAdj	This set point is only used when the heat pump option has been selected. When in the heating mode, the low suction value is reduced by the value of this set point.
163	HP HEAT TARG	If the HP HEAT TARG then the value of this set point will be come the target temperature. Similar to set point #1 when cooling option selected.
164	HP CTL ZONE +	Added to the HP HEAT TARG to create the top of the control zone when the HP HEAT TARG. Similar to set point #2 when cooling option selected.
165	HP CTL ZONE -	Subtracted from the HP HEAT TARG to create the bottom of the control zone when the HP HEAT TARG. Similar to set point #3 when cooling option selected.

13.18. Centrifugal Purge Control Set Points

167	DYN PURGE CT	For information only to show the total number of purges that occurred during the last three purge cycles.
168	PURGE COUNT	If the total number of purges that occurred during the last three purge cycles exceed this count reset all counters and generate a Maximum Purges Exceeded alarm.
169	PURGE PSI ST	When the purge pressure sensor reading is equal or greater than the value of this set point a purge cycle will be initiated. The cycle will be terminated when the purge pressure sensor reading is less than the value of this set point minus 5.0 degree Fahrenheit.
170	EXCESS PURGE	If the time in a purge cycle exceeds the time expressed in seconds the cycle will be terminated and an Excessive Purge Time alarm will be generated.

14. Set points for Magnum Chiller V8 Algorithm (in sequence)

1	CTL TARGET	Control target. This value will be used to develop the Control Zone, refer to set points # 2 & #3. The control target is used with the control zone & rate of change of the controlling sensor to determine required action. The controlling sensor is usually one of the following: Leaving liquid – 99.9% of the time this is the target. Return liquid - Used with large masses, ice rinks, common areas, etc Suction PSI - Continuous running process systems
2	CTL ZONE +	Added to the CTL TARGET to create the top of the control zone.
3	CTL ZONE -	Subtracted from the CTL TARGET to create the bottom of the control zone.
4	HGS TEMP ON	This set point is used with screw compressors that have a hot gas by pass solenoid. When this set point is active and the control temperature is less than the CTL TARGET plus this value and the FLA % is within 25% of the MIN SLIDE% (set point #31), the hot gas by pass solenoid for the compressor on this circuit will be turned on.
5	HGS TEMP OFF	This set point is used with screw compressors that have a hot gas by pass solenoid. When this set point is active and the control temperature is greater than the CTL TARGET plus this value or the FLA % is not within 25% of the MIN SLIDE% (set point #31), the hot gas by pass solenoid for the compressor on this circuit will be turned off.
6	HGS PSI ON	This set point is used with screw compressors that have a hot gas by pass solenoid. When this set point is active and the suction pressure is less than this value and the FLA % is within 25% of the MIN SLIDE% (set point #31), the hot gas by pass solenoid for the compressor on this circuit will be turned on.
7	HGS PSI OFF	This set point is used with screw compressors that have a hot gas by pass solenoid. When this set point is active and the suction pressure is greater than this value or the FLA % is not within 25% of the MIN SLIDE% (set point #31), the hot gas by pass solenoid for the compressor on this circuit will be turned off.
8	L.INJECT.ON	Both the value and safety time fields can be used. This set point is used for both liquid injection solenoids. Value: Liquid injection is turned on when the discharge temperature is equal to or greater than this set point and turned off when the discharge temperature is less than this set point minus 10.0°F (or 5.5°C). Safety Time Field: If the first liquid injection solenoid has been on for a time greater than this value turn on the second liquid injection solenoid.
9	SPRHT TARGET	This is the target for SUPERHEAT that the system will maintain. This value can be dynamically changed, see set point # 110.
10	SPRHT ZONE +/-	This set point, plus or minus the SPRHT TARGET, defines the width of each control zone. (opening/closing, 2x or 4x)
11	EXV LOAD ADJ	EXV adjustment made in response to a load or unload slide adjustment
12	EXV FINE ADJ	The adjustment made when in the 1 st zone above or below the control zone.
13	EXV COURSE	This adjustment made when in the 2 nd zone above or below the control zone and the adjustments are made in 1/2 the time. This adjustment made when above or below the 2 nd control zone and the adjustments are made in 1/4 the time.
14	EXV LOAD DIV	As the amp % changes this divides the EXV % change. Calculate as follows: $(\text{Max slide\%} - \text{min slide\%} / \text{Max vlv\%} - \text{min vlv\%}) + 1$

15	EXV MIN %	This is the minimum valve position allowed when modulating the expansion valve. The calculated position is not allowed to be less then this set point. This value should be set so when hot gas is applied the valve opening is adequate.
16	EXV MAX %	This is the maximum position allowed when modulating the expansion valve to maintain the SUPERHEAT target. This value should be the valve% opening at 100% capacity + 10 to 15 %.
17	LO SUPERHEAT	If the calculated SUPERHEAT remains below this value for the time specified, the system will place the associated value in the LOW SPR STATE and generate LOW SUPERHT alarm.
18	LOWSUCPSI DLY	Delay in seconds when in Low Suction PSI Opening
19	EXV DELAY	Delay in seconds between valve adjustments. Should not be less than 48. (When adjusting at 4x this will allow 12 seconds to see the result before making the next adjustment.
20	EXV STRT TIME	This is a time (in seconds) to hold the valve at the start % set point when the compressor starts. Since the SUPERHEAT calculation is not valid when the compressor is not running the EXV logic sets the valve to a giving position for a given time in order to allow the system to run and develop a valid SUPERHEAT temperature. This set point contains the given time to hold the valve at the given opening. (See set points #113 to #120 for the time).
21	MAX TRG RESET	This value is used to adjust the control CHL OUT TARG set point #1. The sensor input value will vary be between 0 and 5 volts and the actual adjustment will be proportion from negative MAX TRG RESET value to positive MAX TRG RESET value.
22	LOW AMBIENT	If the ambient temperature is below this value the package will be disabled, unit state will be AMBIENT OFF. Once off on low ambient the unit will remain off until the ambient rises above this set point value by 5.0F (or 2.5C).
23	POWERUP DELAY	This is the time that the system will remain in the START UP state before moving to the next state.
24	HI AMBIENT	If the ambient temperature is above this value the package will be disabled, unit state will be AMBIENT OFF. Once off on high ambient the unit will remain off until the ambient drops below this set point value by 5.0F (or 2.5C).
25	STEP SENSTIY	This value is used to adjust the speed of responding to changes in the control algorithm. 1= faster response HIGHER number's = slower response. Used only with the MAGNUM Control Zone control method.
26	STEP DELAY	Both the value and safety time fields can be used. Value: This is the time delay before increasing or decreasing the number of refrigeration steps. Used only with the MAGNUM Control Zone control method. Safety Time Field: If used, this will force a minimum time delay between two compressor starts.
27	MAX ROC -	Maximum negative Rate Of Change allowed before stopping the unit from loading. If the actual ROC is less than this value the capacity control state is placed in the HOLDING state. Used only with the MAGNUM Control Zone control method.
28	MAX ROC +	Maximum positive Rate Of Change allowed before stopping the unit from unloading. If the actual ROC is greater than this value the capacity control state is placed in the HOLDING state. Used only with the MAGNUM Control Zone control method.
29	ROC INTERV	Number of second between the samples used for calculating the actual Rate Of Change. Used only with the MAGNUM Control Zone control method. Maximum 60 seconds

30	MAX SLIDE %	Indicates the maximum slide or speed allowed. If speed limit it is usually set to 100%. In variable step control, it limits the slide load until all compressors are on or the number on is greater than set point #102, STEP CMP LIM, then they will all loaded to 100% of FLA.
31	MIN SLIDE %	Both the value and safety time fields can be used. Value: Indicates the minimum slide or speed allowed. Usually 40%. This is where the slide valve or the inverter will be set when the compressor is turned on. This % is a function of current amp draw relative to current FLA. Safety Time Field: If used, this will force a time delay before unloading all running compressors before the next compressor is started.
32	MAX ADJUST %	Indicates the maximum percentage change that can be made to the slide valve or the inverter when more cooling capability is needed.
33	MIN ADJUST %	Indicates the minimum percentage change that can be made to the slide valve or the inverter when less cooling capability is needed.
34	SLIDE SENSITY	This allows control of the adjustment made to slide wanted percentage. The adjustment is relative to the difference between current leaving liquid temperature and target. The larger the value the larger the adjustment. (Almost always a 1 but should not be greater than 3.)
35	AMP DB HI	This set point is only used in the screw compressors. This value is the upper dead band limit to stop pulsing the slide valve. If the actual amps are within the dead band, the slide valve will not be moved.
36	AMP DB LO	This value is the lower dead band limit to stop pulsing the slide valve. If the actual amps are within the dead band, the slide valve will not be moved.
37	LOAD PULSE	Length of time to turn on the slide valve load solenoid. Time is expressed in 1/10 of a second. (This value should be between 1 & 9.)
38	UNLOAD PULSE	Length of time to turn on the slide valve unloader solenoid. Time is expressed in 1/10 of a second. (This value should be between 1 & 9.)
39	LUBE OIL TMP	Used only with screw compressors with oil, the oil must reach this temperature before the system will move out of the LUBE state.
40	LUBE OIL PSI	Used only with screw compressors with oil, the oil must reach this pressure before the system will move out of the LUBE state.
41	LUBE DELAY	Used only with screw compressors with oil, this is the maximum time that a compressor can be in the LUBE state. When this time is exceeded, an alarm is generated and the circuit is placed in a lockout state. Both the oil temperature and pressure must be satisfied before the LUBE state will be exited.
42	SPARE	
43	SPARE	
44	SPARE	
45	CND STG1 ON	Air cooled- When the discharge pressure is above this value; turn on the first stage of the condenser fans.
46	CND STG1 OFF	Air cooled- If stage 1 is on and the discharge pressure drops below this value turn off the first stage of condenser fans.
47	CND DIFF ON	Air cooled- Differential PSI to turn on the remaining stages of condenser fans.
48	CND DIFF OFF	Air cooled- Differential PSI to turn off the remaining stages of condenser fans.
48	CND DELAY	Water cooled- if active, this is the time in seconds between adjustments to the water valve. If inactive, then 30 seconds will be used as the delay.
48	DUAL PSI DELTA	Dual V8 – Difference in pressure before stage 2 can be entered.
49	CND MIN RUN	Air cooled- Once a condenser fan stage has been turned on; it will remain on for at least the amount of minutes specified in this set point.
49	DUAL TIME DELAY	Dual V8 – Time delay once the pressure difference as been reached before stage 2 can be entered.

49	CND MIN RUN	Air cooled- Once a condenser fan stage has been turned on; it will remain on for at least the amount of minutes specified in this set point.
49	CND VLV START	Water cooled- If the valve opening is less than set point 52 and this set point is active; make the valve opening equal to this set point. This enables minimum opening to be set at larger opening percentage.
50	CND VLV TARG	Water cooled- Target discharge pressure to maintain by integration and Rate of Change logic.
51	CND VLV DIV	Water cooled- Usually 1. Allows scaling of the amount the valve is adjusted. The larger the number the smaller the valve adjustment as the adjustment will be divided by this value.
52	CND VLV MIN	Water cooled- Minimum valve opening percentage allowed.
53	CND VLV ROC-	Water cooled- Maximum negative discharge pressure Rate of Change allowed. If the actual rate of change is less then this set point then stop opening the valve. The absolute value of this set point also serves as the maximum positive rate of change allowed. If the actual rate of changes is greater than the absolute value of this set point then stop closing the valve.
54	CND MIN SPD	Air cooled- Minimum speed percentage for variable speed condenser control.
54	CND VLV MULT	Water cooled- Allows scaling of the amount the valve is adjusted. The larger the number the larger the valve adjustment as the adjustment will be multiplied by this value.
55	CND MAX SPD	Air cooled- Maximum speed percentage for variable speed condenser control.
56	PULSE DELAY	Both the value and safety time fields can be used. Value: Used with infinite capacity screws. The number of seconds between load or unload pulses. (Should be between 3 & 5. Allows load change to be checked before next pulse. Eliminates oil foaming when unloading too fast.) Safety Time Field: If used, this is the fast unloading state time delay (previous was a fixed value now it is adjustable).
57	LO AMB PROC	When this set point is active and there is a process pump, when the ambient temperature is less than the value of this set point the process pump will be turned on. The process pump will be turned off when the ambient temperature is greater than the value of this set point 5.0 degrees Fahrenheit.
58	CFG TESTING	This MUST be setup as 'Not Used' or be set to '1', in a configuration running in the field, or the micro will not stop when an I/O communications signal is lost.
59	ACYC OFF->ON	This is the anti cycle time delay (in seconds) based on when the compressor was turned off. This value is used in a calculation to determine how long a compressor should be in the anti-cycle state. Refer to the Standard Control Options section, Compressor Anti-Cycle Logic. (OFF to ON)
60	SPARE 60	
61	PMP DWN OFF	This is the suction pressure value for turning off the compressor when in the PUMP DOWN state.
62	PMP DWN DELY	Maximum time delay (in seconds) that a compressor can remain in the PUMP DOWN state.
63	ACYC ON->ON	This is the anti cycle time delay (in seconds) based on when the compressor was turned on. This value is used in a calculation to determine how long a compressor should be in the anti-cycle state. Refer to the Standard Control Options section, Compressor Anti-Cycle Logic. (ON to ON)
64	COMP MIN RUN	This is the minimum run time (in minutes) for a compressor once it is turned on. This minimum run time is bypass only for the safeties.

65	FLA COMP#1	<p>Full Load Amps for the compressor on circuit 1. For screw compressors, the ampere when the compressor is fully loaded. This value is used to calculate the compressor current FLA %, which is used to control the loading and unloading of the slide valve.</p> <p>This value is used to calculate the high and the low ampere safeties limits. Refer to set points 75 and 76.</p> <p><u>Note: This is the amps at design suction & head referenced in cfg RO screen.</u></p>
66	FLA COMP#2	<p>Full Load Amps for the compressor on circuit 2. Refer in set point 65 for definition.</p>
67	FLA COMP#3	<p>Full Load Amps for the compressor on circuit 3. Refer in set point 65 for definition.</p>
68	FLA COMP#4	<p>Full Load Amps for the compressor on circuit 4. Refer in set point 65 for definition.</p>
69	FLA COMP#5	<p>Full Load Amps for the compressor on circuit 5. Refer in set point 65 for definition.</p>
70	FLA COMP#6	<p>Full Load Amps for the compressor on circuit 6. Refer in set point 65 for definition.</p>
71	FLA COMP#7	<p>Full Load Amps for the compressor on circuit 7. Refer in set point 65 for definition.</p>
72	FLA COMP#8	<p>Full Load Amps for the compressor on circuit 8. Refer in set point 65 for definition.</p>
73	STARTER DLAY	<p>Time delay (in seconds) between the first and second relay being turned on. Used for part wind (typical value of 1) and star delta (typical value of 5) starter.</p>
74	OIL PUMP OFF	<p>If oil pump is always on (specified in the MCS-Config program), this set point is not used. If oil pump is not always on then this set point contains the PSI value when the oil pump is to be turned off.</p>
75	HI AMPS	<p>This set point is a percentage of the FLA; it is used to create the high amp draw limit. Depending on the circuit that is being tested: the value of this set point is multiplied by either the value in set points 65 through 72 to obtain the circuit's high limit. This value is tested in the high amp safety, if the amps exceed this value for the time specified in this set point the safety is tripped.</p>
76	LO AMPS	<p>This set point is a percentage of the FLA; it is used to create the low amp draw limit. Depending on the circuit that is being tested: the value of this set point is multiplied by either the value in set points 65 through 72 to obtain the circuit's low limit. This value is tested in the low amp draw safety, if the amps are below this value for the time specified in this set point the safety is tripped.</p>
77	LOW SUCTION	<p>If active, the system checks for low suction pressure for each running compressor. The system will compare the suction pressure sensor reading to this value. It must be less than the value for the period of time specified in the set point before this set point will trip.</p> <p><u>Digital or analog – Refers to 'Suction Pressure' column under circuits under Chiller V8 tab of MAG-Config</u></p>

78	LO SUCT UNLD	The purpose of this set point is to take corrective action before a low suction pressure safety occurs. If a circuit has more than one step and it is fully loaded and if the suction pressure is less than the value of the safety set point (LOW SUCTION) plus the value of this set point, the system will turn off one step of capacity. An infinite step compressor will be forced to unload until the suction pressure rise above the calculated value. The circuit state will be changed to LO SUCT HOLD. The circuit will remain in this state for a minimum of 5 minutes. At that time, if the suction pressure has increased to a level greater then the value of set point LOW SUCTION plus the value of set point LOW SUCT RELD the compressor will return to normal control.
79	LOW SUCT RELD	See set point 78 description
80	UNSAFE SUCT	If active, the system checks for low suction pressure that is in an unsafe condition for each running compressor. The system will compare the suction pressure sensor reading to this value. It must be less than the value for the period of time specified in the set point before this set point will trip. Note the time period specified should be very short, 2-5 seconds. This safety set point trips the circuit to the LOCKOUT state immediately, no retry.
81	HI DISCH PSI	If active, the system checks for high discharge pressure condition for each running compressor. The system will compare the discharge pressure sensor reading to this value. It must be greater for the period of time specified in the set point before this safety will trip. <u>Digital or analog – Refers to ‘Discharge Pressure’ column under circuits under Chiller V8 tab of MAG-Config</u>
82	HI DISC UNLD	The purpose of this set point is to take corrective action before a high discharge pressure safety occurs. If a circuit has more than one step and it is fully loaded and its discharge pressure exceeds the value of the safety set point HI DISCH PSI (set point 81) minus this set point, the system will turn off one step of capacity. A screw compressor will be forced to unload until the discharge pressure falls below the calculated value. The circuit state will be changed to HI DISC HLD. The circuit will remain in this state for a minimum of 5 minutes. At that time if the discharge pressure has dropped below the value of the HI DISCH PSI minus the HI DISC RELD (set point 83) the compressor will return to normal control.
83	HI DISC RELD	This set point works in conjunction with set point 82. Refer to that set points description.
84	LO DISC SHEAT	This set point contains the value that indicates a low discharge SUPERHEAT condition. If the calculated discharge SUPERHEAT is less than this value, the low discharge SUPERHEAT timer will be set to 120 seconds. This will keep the low discharge SUPERHEAT RO on for that period of time. (This can be used as a warning only or the user may wire through the low discharge superheat relay to solve the problem.)
85	LO DISC PSI	If active, the system checks for low discharge pressure. The system will compare the sensor reading to this value. It must be less than the value for the period of time specified in the set point before a safety trip occurs.
86	HI RETURN TEMP	If active the system will check for high temperature of the entering liquid. If this temperature is greater than the value in this set point, the system will move the circuit's state to HI WATER HOLD. This is similar to other holding states.
87	HI DISCH TMP	If active, the system checks for high discharge temperature condition for each circuit that has at least one step on. The system will compare the discharge temperature sensor reading to this value. It must be greater for the period of time specified in the set point before this safety will trip. <u>Digital or analog – Refers to ‘Suction Temperature column under circuits under Chiller V8 tab of MAG-Config</u>

88	HDISCT UNLD	The purpose of this set point is to take corrective action before a high discharge temperature safety occurs. If a circuit has more than one step and it is fully loaded and its discharge temperature exceeds the value of the safety set point HI DISCH TMP (set point 87) minus this set point, the system will turn off one step of capacity. A screw compressor will be force to unload until the discharge temperature falls below the calculated value. The circuit state will be changed to HI DISC HLD. The circuit will remain in this state for a minimum of 5 minutes. At that time if the discharge temperature has dropped below the value of the HI DISCH TMP minus the HI DISC RELD (set point 89) the compressor will return to normal control.
89	HDISC T RELD	This set point works in conjunction with set point 88. Refer to that set points description.
90	COND FAULT	This set point is used to determine the action when a system has condensers with fault indicators and one indicates a fault. If this set point is active and a condenser fault occurs, a set point alarm message will be generated. If this set point type is LOCKOUT then all of the circuits associated with this fault will be locked off. Or Time in seconds for the delay before the by pass can be used when a fault has occurred for a condenser type of Common VFD Fan w/Bypass.
91	LOW OIL DIF	If active, the system checks for low differential oil pressure. The system will compare the calculated differential oil pressure to this value. It must be less than the value for the period of time specified in the set point before the safety will trip. <u>Digital or analog – Refers to ‘Oil Pressure’ column under circuits under Chiller V8 tab of MAG-Config</u>
92	UNSAFE OIL	If active, the system checks for low differential oil pressure. The system will compare the calculated differential oil pressure to this value. It must be less than the value for the period of time specified in the set point before the safety will trip. The time delay for this set point should be very short 2-5 seconds. This safety trips to a lockout no retries are attempted. Manual intervention is required.
93	HI OIL SEAL	Only used with a screw or centrifugal compressor. If the oil seal / or oil cooler temperature exceeds the value of this set point the system for the time specified, this safety will trip.
94	HI OIL TEMP	If active, the system checks for high oil temperature. The system will compare the oil temperature sensor reading to this value. It must be ON or greater for the period of time specified in the set point before this set point will trip. The sensor can be either an analog or digital input. <u>Digital or analog – Refers to ‘Oil Temp’ column under circuits under Chiller Chiller V8 tab of MCS-Config</u>
95	MOTOR FAULT	If active, the system checks for high motor temperature. This can be either a digital input or an analog input, the system will compare the sensor reading to this value. It must be ON or greater for the period of time specified in the set point before this set point will trip. <u>Digital or analog – Refers to ‘Motor Temp’ column under circuits under Chiller V8 tab of MCS-Config</u>
96	NO CMP PROOF	If this set point is active and there is a digital input indicated for compressor proof, when the compressor is on, the compressor proof will be checked for that circuit.
97	DIRTY FILTER	Only used for screw compressors. If the discharge pressure minus the oil filter pressure is greater than this value for the time specified a safety trip would occur.

98	LLS#2 ON	<p>The value, safety time and delay between trips fields can be used.</p> <p>This set point is used to control a 2nd liquid line solenoid.</p> <p>Value: When the chiller capacity wanted is greater then this value for number of seconds contained in the Safety Time Field the 2nd liquid line solenoid will open. When the circuit capacity is below the value in Delay Between Trips Field the value will be turned off.</p> <p>Safety Time Field: This field contains a forced delay before the solenoid will be turned on. If it is zero then there will be no delay.</p> <p>Delay Between Trips Field: This field contains the cut off offset for turning this solenoid off. If it is zero then an offset of 20 will be used.</p>
99	LLS#3 ON	<p>The value, safety time and delay between trips fields can be used.</p> <p>This set point is used to control a 3rd liquid line solenoid.</p> <p>Value: When the chiller capacity wanted is greater then this value for number of seconds contained in the Safety Time Field the 3rd liquid line solenoid will open. When the circuit capacity is below the value in Delay Between Trips Field the value will be turned off.</p> <p>Safety Time Field: This field contains a forced delay before the solenoid will be turned on. If it is zero then there will be no delay.</p> <p>Delay Between Trips Field: This field contains the cut off offset for turning this solenoid off. If it is zero then an offset of 20 will be used.</p>
100	LO REFR UNLD	<p>If the refrigerant temperature drops below this value, the circuit will unload in an attempt to prevent the low refrigerant temperature safety from occurring. This is only active in software CHL C.</p>
101	SFTYHOLD DLY	<p>Time in seconds to hold before trying to reload when the capacity has been decreased to avoid a safety, (Examples: high disc psi, high disc temp, low suct psi, etc.)</p>
102	Spare 102	
103	LEAD COMP	<p>Enables the user to specify the lead compressor. If a value is less than the maximum number of compressor the lead indicator is set to this value. If the value is zero then auto rotation is enabled.</p>
104	COMP ROTATION	<p>Specifies the number of days between rotation (set point #103 must be set to zero to enable auto rotation). If the value is zero then rotation will occur with every capacity cycle.</p>
105	PUMP FAILURE (NO FLOW)	<p>If active and flow is lost and only one pump is present the system will move to a LOCK OUT state. If the system has two pumps and flow is lost the backup pump will start and the lead pump will be locked out. If the second pump is running and flow is lost then the entire system will be locked out. A lock out reset will be required to restart the system or to reactive a locked out pump.</p> <p>If inactive and the flow is lost, the system will move to the OFF- NO EVAP FLOW state. When flow is returned the system will automatically restart, no reset is required.</p> <p>This set point had been referred to as the NO FLOW.</p>
106	LEAD PUMP	<p>Enables the user to specify the lead pump.</p>
107	EcoDelayMech	<p>Value in seconds is the delay after the economizer is fully loaded, valve opened to its maximum and all associated fans are on, before the mechanical cooling is enabled. . If this set point is inactive then the value of set point #125 will be used for this delay.</p>
108	PUMP DELAY	<p>Time delay in seconds to keep the chilled water pump running after the last compressor has been turned off. This will help insure that a chiller barrel does not freeze up.</p>

109	HiRefLevel	This set point has two functions. If active, the system checks for high refrigeration level. The system will compare the sensor reading of the refrigeration level sensor to this value. It must be greater than the value for the period of time specified in the set point before a safety trip occurs. If active, and the system has EXV values, if the superheat for a circuit is greater than this value the EXV valve adjustment will be set to the value in set point #13, EXV COURSE, times -3.
110	LoRefLvlTarg	If the low super heat safety timer has reached one third of the safety time in set point #84, LO DiscSPRHT and it is active then set point #9, REF LVL TARG value will be set to the value of this set point,
111	FREEZE	If active, the system checks for freeze protection. The system will compare the chilled water out temperature to this value. It must be less than the value for the period of time specified in the set point before this safety will trip.
112	NO STOP	This set point is used to insure that a compressor is actually off when the system has called for it to be off. The value of the set point contains a percentage of the FLA COMP set points 65-72. If the compressor ampere is greater then this percentage of the FLA set point for the period specified the compressor is still running and the entire unit is locked out and a NO STOP alarm is generated. If a Control power relay is setup then it will be turned off when this safety trips.
113 to 114	Reversed	These set points will not be used. They are reversed for use by user defined functions.
115	EcoVFDfanDely	If the fluid cooler has a condenser VFD fan associated with it, this set point will be the time delay in seconds between adjustments to the VFD. If this set point is inactive then the value of set point #124 will be used for this delay timer.
119	EcoOffsetON	Temperature off set used to determine if the economizer function could be started. The ambient temperature must be less than target temperature minus the value of this set point. For example if the target is 45.0F and this value is 10.0F then the ambient temperature must be less than 35.0F to enable the economizer to begin.
120	Eco Stg Dely	Once the economizer valve has been opened to its maximum and all fans associated only with the economizer if any have been turned on; the economizer function will wait this time, expressed in seconds, before the first condenser fan is turned on or if a VFD it will be set to its minimum position. The minimum setting of the VFD is the value of set point #54.
121	Eco MIN VLV%	Economizer minimum Analog Output valve %. When the economizer function begins the valve is opened to this value. When closing the valve this will be the minimum setting. This set point must be active to indicate that the Economizer AO option is active.
122	Eco MAX VLV%	Economizer maximum Analog Output valve %. This is the maximum that the valve can be opened.
123	Eco MAX ADJ	Economizer maximum adjustment to the Analog Output valve % with each calculation. Example: $\{abs(Target - current) * Multiplier\} / Divisor$
124	EcoVlvAdjDly	Economizer delay between output valve adjustments.
125	Eco StageDly	Time delay once the valve has been opened to its maximum and turning on the associated condenser fans.
126	Eco MULTI	Economizer multiplier to scale adjustment to Analog Output valve %. The difference between the control temperature and its target will be multiplied by this value.
127	Eco DIVIDE	Economizer divisor to scale adjustment Analog Output valve %. The difference between the control temperature and its target will be divided by this value.

128	PRTWIND FAIL	If aux contact available this set point allows detection of a part wind failure
129	RH CUTIN	Reheat cutin temperature
130	RH CUTOFF ADJ	Reheat cutoff temperature is developed by adding this value to set point #129
131	RH START DLY	Reheat delay in seconds before starting
132	RH BLEED DLY	Reheat delay in seconds before starting bleeding of gas
133	RH STAGE DLY	Reheat delay in seconds before starting next stage of reheat
134	BARREL HEATER	Set point at which barrel heater will be turned on when ambient drops below.
135	REFRIG LEAK	A digital signal from a refrigerant leak detector
136	VI PULSE	Used with an adjustable VI, volume ratio. This is the pulse time expressed in tenths of second to move the VI.
137	VI DEADBAND	Used with an adjustable VI, volume ratio. If the VI reading is greater than the vi wanted ratio plus the value of this set point then the increase RO is off and the decrease RO is pulsed. . If the VI reading is less than the vi wanted ratio minus the value of this set point then the increase RO is pulsed and the decrease RO is off.
138	VI DELAY	Used with an adjustable VI, this is the time delay between calculating a the vi wanted ratio.
139	OIL FLOAT	If active, the system checks for low oil. The system will check the oil float digital input. It must be ON for the period of time specified in the set point before this set point will trip.
140	LOW SI CIRCUIT OFF	Circuits with low SI Off sensor will be disabled when sensor is below this set point.
141	HI SI CIRCUIT OFF	Circuits with hi SI Off sensor will be disabled when sensor is above this set point.
142	SERVICE MODE	This set point if not zero indicates that a compressor that is disabled with its pump down switch being on is to be continually pumped down until its suction pressure is zero. The compressor will be turned on to perform the pump down the number of times indicated in this set point. This is to enable service to be preformed on the compressor.
143	UNLOADED %	Used if a slide percentage open sensor exists, when this sensor 's value is less than the value of this set point the slide is considered closed.
144	OIL HEATER ON	This set point is used with a compressor that has an oil heater. The oil heater is turned on if the oil temperature is less than the value of this set point. It will be turned off if the oil temperature is greater than the value of this set point plus 5.0 degrees Fahrenheit.
145	OIL COOLER ON	This set point is used with a compressor that has an oil cooler. The oil cooler is turned on if the oil seal temperature is greater than the value of this set point. It will be turned off if the oil seal temperature is less than the value of this set point minus 5.0 degrees Fahrenheit.
146	BLOWER TARG	Blower static pressure target
147	BLOWER ZONE	Blower static pressure \pm control zone
148	BLOWER DELY	Blower delay, in seconds, before next change.
149	BLWR MAX ROC	Blower slope, rate of change. If the slope exceeds this value no change is required.
150	BLWR MIN SPD%	Blower minimum speed.
151	UNLOADED OFF	When this set point is active and the system is fully unloaded with only one step on and the control temperature is greater than this value the capacity state will be set to holding.

152	HP OVERHEAT	This set point is only used when the heat pump option has been selected. This set point is to protect against overheating of a heat pump with unloaders or variable speed. When this set point is active and there is a leaving temperature sensor and it valve is greater than this set point minus 3.0 degrees Fahrenheit the circuit will enter the high temp unload state. The temperature must drop to less than this set point minus 4.5 degrees Fahrenheit before the system will move to the holding state.
153	SftyUnld Del	This set point contains the time delay in seconds between compressor capacity adjustment when safety unloading.
154	VFD Sfty Adj	This set point contains the percentage of VFD adjustment when in safety unloading - amount to adjust every time delay.
155	LO REF TMP	This set point is only used with CENTRIFUGAL compressors. If active, the system checks for low refrigerate temperature. The refrigeration temperature must be less than the value of this set point for the period of time specified in the set point before this set point will trip.
156	LO REF UNLD	This set point is only used with CENTRIFUGAL compressors. The purpose of this set point is to take corrective action before a low refrigerate temperature safety occurs. The slide will unload when the refrigerate temperature is less than the value of the safety set point LO REF TMP (set point 155) plus this set point. The circuit state will be changed indicate temperature unloading. The circuit will remain in this state until the refrigerate temperature is above the value of the LO REF TMP plus twice the value of this set point the compressor state will be temperature hold.
157	HP LoSuctAdj	This set point is only used when the heat pump option has been selected. When in the heating mode, the low suction value is reduced by the value of this set point.
158	DEF TRIG TMP	If a defrost option has been specified and either coil #1 or coil #2 temperature if they exist is less than or equal to the value of this set point a defrost cycle will be started if sufficient time has elapsed since the last defrost.
159	DEF TRIG DEL	This set point contains the time expressed in minutes between defrost cycles.
160	DEF REV DEL	If there is a reversing valve, this is the delay expressed in minutes that the system must wait once the valve has been turned on before the defrost cycle can continue.
161	DEF TERM TMP	Once a defrost cycle begins it can be terminated when both coil #1 and coil #2 temperature if they exist are greater than the value of this set point.
162	DEF TERM DEL	Once a defrost cycle begins it will be terminated when the time this value expressed in minutes.
163	HP HEAT TARG	If the HP HEAT TARG then the value of this set point will be come the target temperature. Similar to set point #1 when cooling option selected.
164	HP CTL ZONE +	Added to the HP HEAT TARG to create the top of the control zone when the HP HEAT TARG. Similar to set point #2 when cooling option selected.
165	HP CTL ZONE -	Subtracted from the HP HEAT TARG to create the bottom of the control zone when the HP HEAT TARG. Similar to set point #3 when cooling option selected.
166	PHASE LOSS	Specifies the number of minutes to wait after phase loss before allowing unit to begin running again. Enter number of minutes to wait in "Time in Safety"
167	DYN PURGE CT	For information only to show the total number of purges that occurred during the last three purge cycles.
168	PURGE COUNT	If the total number of purges that occurred during the last three purge cycles exceed this count reset all counters and generate a Maximum Purges Exceeded alarm.

169	PURGE PSI ST	When the purge pressure sensor reading is equal or greater than the value of this set point a purge cycle will be initiated. The cycle will be terminated when the purge pressure sensor reading is less than the value of this set point minus 5.0 degree Fahrenheit.
170	EXCESS PURGE	If the time in a purge cycle exceeds the time expressed in seconds the cycle will be terminated and a Excessive Purge Time alarm will be generated.

15. AUTHORIZATION FUNCTION

The authorization code is a special four-character code that enables access in to the MAGNUM system. The code must be numeric with values between 1 and 8 if it is to be entered from the Keypad/Display. If the system is being accessed via MCS-Connect program, the code may consist of any valid alpha/numeric characters. Each system can have up to 15 different authorization codes. This provides the capability of issuing different codes to different people if desired. There are four levels of authorization, which provide different capabilities with in the system. The authorization code and the associated level cannot be displayed or viewed in an MAGNUM system. These are established when building the configuration file in the **MCS-Config** program. The authorization codes must be protected and remain confidential, if they are compromised unauthorized personnel can gain access to the system.

From the Keypad/Display the following changes can be made based upon the authorization level:

FUNCTION	VIEW	USER	SERVICE	SUPERVI -SORY	FACTORY
SENSOR OFFSETS	NO	NO	YES	YES	YES
SENSOR DIAGOSTICS	NO	NO	YES	YES	YES
CLEAR ALARM HISTORY	NO	NO	NO	NO	YES
CLEAR POINT INFORMATION	NO	NO	NO	NO	YES
DATE & TIME SET	YES	YES	YES	YES	YES
DAY OF WEEK SET	YES	YES	YES	YES	YES
CHANGE NO FLOW LOCKOUT OR SHUT DOWN	NO	NO	NO	NO	YES
CHANGE ROTATE YES OR NO	NO	NO	NO	NO	YES
CHANGE MANUAL/AUTO SETTINGS	NO	NO	NO	YES	YES
CHANGE SET POINT VALUES	*	*	*	*	YES
CHANGE OPERATING SCHEDULES	NO	NO	YES	YES	YES
CHANGE HOLIDAY DATES	NO	NO	YES	YES	YES
LOCK OUT RESET	**	**	**	**	YES
CHANGE RS485 NETWORK SETTINGS	NO	YES	YES	YES	YES
CHANGE ETHERNET NETWORK SETTINGS	NO	YES	YES	YES	YES
ADJUST KEYPAD DISPLAY CONTRAST	YES	YES	YES	YES	YES

* Note - before a set point can be changed the set point must be able to be viewed. See set point level for each individual set point.

**See configuration for authorization levels that are allowed unlimited resets per day. Authorization levels below Auth Level Bypass are allowed a limited number of resets. Authorization levels at and above Auth Level Bypass are allowed unlimited lockout resets.



To get authorized on Magnum do the following:

1. Press 'Menu'
2. Using ↑, ↓, →, or ← position cursor to 'Passwords'
3. Press ↵ key.
4. Enter 4 digit password & press ↵.
5. Press 'Menu' to make next selection.

16. Standard Control Options

The following options are specified in the **MCS-Config** program when building the configuration. These options are used to personalize the system to meet the individual control requirements.

16.1. General Options

- Control method can be based upon the control zone strategy or upon a voltage input that indicates the number of stages to be on.
- The control temperature can specify either the return or leaving sensor.
- Electronic expansion valves with dynamic movement based on capacity changes
- Chilled water reset from the BMS.
- Condenser control allowing correct discharge superheat for good oil separation.
- Evaporator pump control.
- Anti recycle timers allow off to on & on to on. (All circuits)
- Number of circuits, maximum of eight with selectable compressor rotation.
- Warning RO, this point will be turned on for low suction unload, high discharge unload, etc.
- Alarm RO, this point will be turned on when ever an alarm is generated.
- Specify auto rotation for circuits.
- Low and/or high ambient shut down.

16.2. Compressor Types

The compressor type is selected from a drop down list in the Compressor Information section under the MAG CHL button.

Compressor Information

Compressor Type: Recip comp with Oil

Type:

- Hanbell-Load NO
- Centrifugal Comp
- Mitsubishi Screw
- TubroCor
- Trane Screw
- McQuay Frame 4
- Fu Sheng
- Hanbell-Load NC
- Hanbell-3 Solenoid(50-100%)

Unit Type:

Cooling Only HeatPump Electric Heat

CW Pump/Fan Defrost:

On During Def. Off During Def.

Heat Mode Indicator: Not Used

Defrost Type: None

Common Reversing Valve: Not Used

Pre-Pump Out:

Yes No

100% when starting next? Yes No

Starting Next (0-120) Seconds: 0

Fast Unload Delay (30-120) Seconds: 30

Minimum Delay Between Compressor Starts (0-300) Seconds: 0

Last Stage to 100% (Override Setpoint): Yes No

- Recip Comp w/Oil
- Recip Comp w/o Oil
- Screw Comp w/ Oil
- Scroll Comp
- Hitachi Screw
- Bitzer Screw
- Hartford Screw
- Carlyle Screw
- Hanbell-Load NO (load solenoid wired to normal open)
- Hanbell-Load NC (load solenoid wired to normal close)
- Hanbell- 3 Solenoid (50-100%) (not variable but 3 fixed step screw)

- Centrifugal
- Mitsubishi Screw
- TubroCor
- Trane Screw
- McQuay Frame 4
- Fu Sheng

The type of compressor will determine the relay output sequence plus how the compressor is controlled.

16.3. Sequence of Compressor Related Relay Outputs

The sequence of relay outputs must be correct. Relays are required unless marked as optional. If a relay is optional and it is not used then its position is skipped and the following relays will be moved up.

16.3.1. Recip Comp w/Oil

Compressor relay
 Part winding compressor relay (OPTIONAL)
 Liquid line solenoid
 Unloader 1 (OPTIONAL)
 Unloader 2 (OPTIONAL)
 Unloader 3 (OPTIONAL)
 Oil pump (OPTIONAL)
 Oil heater (OPTIONAL)
 Hot gas bypass (OPTIONAL)
 Liquid injection (OPTIONAL)
 Fast unloader – not Hitachi (OPTIONAL)
 Second liquid line solenoid (OPTIONAL)
 Oil equalization (OPTIONAL)
 Oil seal cooler (OPTIONAL)
 VI increase valve % (OPTIONAL)
 VI decrease valve % (OPTIONAL)
 Start unloader by pass (OPTIONAL)
 Low disc super heat (OPTIONAL)
 Hot gas reheat off (OPTIONAL) If hot gas reheat all 3 relays are required.
 Hot gas reheat on (OPTIONAL)
 Hot gas reheat bleed (OPTIONAL)
 Third liquid line solenoid (OPTIONAL)
 Reversing valve (heat pump) (OPTIONAL)
 Liquid injection #2 (OPTIONAL)
 Mod motor (OPTIONAL)

16.3.2. Recip Comp w/o Oil

Compressor relay
 Part winding compressor relay (OPTIONAL)
 Liquid line solenoid
 Unloader 1 (OPTIONAL)
 Unloader 2 (OPTIONAL)
 Unloader 3 (OPTIONAL)
 Hot gas bypass (OPTIONAL)
 Liquid injection (OPTIONAL)
 Second liquid line solenoid (OPTIONAL)
 Oil equalization (OPTIONAL)

Oil seal cooler (OPTIONAL)
VI increase valve % (OPTIONAL)
VI decrease valve % (OPTIONAL)
Start unloader by pass (OPTIONAL)
Low disc super heat (OPTIONAL)
Hot gas reheat off (OPTIONAL) If hot gas reheat all 3 relays are required.
Hot gas reheat on (OPTIONAL)
Hot gas reheat bleed (OPTIONAL)
Third liquid line solenoid (OPTIONAL)
Reversing valve (heat pump) (OPTIONAL)
Liquid injection #2 (OPTIONAL)
Mod motor (OPTIONAL)

16.3.3. Screw Comp w/ Oil

Compressor relay
Part winding compressor relay (OPTIONAL)
Loader
Unloader
Oil pump
Oil heater
Liquid line solenoid (OPTIONAL)
Hot gas bypass (OPTIONAL)
Liquid injection (OPTIONAL)
Second liquid line solenoid (OPTIONAL)
Oil equalization (OPTIONAL)
Oil seal cooler (OPTIONAL)
VI increase valve % (OPTIONAL)
VI decrease valve % (OPTIONAL)
Start unloader by pass (OPTIONAL)
Low disc super heat (OPTIONAL)
Hot gas reheat off (OPTIONAL) If hot gas reheat all 3 relays are required.
Hot gas reheat on (OPTIONAL)
Hot gas reheat bleed (OPTIONAL)
Third liquid line solenoid (OPTIONAL)
Reversing valve (heat pump) (OPTIONAL)
Liquid injection #2 (OPTIONAL)
Mod motor (OPTIONAL)

16.3.4. Scroll Comp

Compressor relay
Part winding compressor relay (OPTIONAL)
Liquid line solenoid
Unloader 1 (OPTIONAL)
Unloader 2 (OPTIONAL)
Unloader 3 (OPTIONAL)
Hot gas bypass (OPTIONAL)
Liquid injection (OPTIONAL)
Second liquid line solenoid (OPTIONAL)
Oil equalization (OPTIONAL)
Oil seal cooler (OPTIONAL)
VI increase valve % (OPTIONAL)
VI decrease valve % (OPTIONAL)
Start unloader by pass (OPTIONAL)

Low disc super heat (OPTIONAL)
 Hot gas reheat off (OPTIONAL) If hot gas reheat all 3 relays are required.
 Hot gas reheat on (OPTIONAL)
 Hot gas reheat bleed (OPTIONAL)
 Third liquid line solenoid (OPTIONAL)
 Reversing valve (heat pump) (OPTIONAL)
 Liquid injection #2 (OPTIONAL)
 Mod motor (OPTIONAL)

16.3.5. Hitachi Screw

Compressor relay
 Part winding compressor relay (OPTIONAL)
 Loader
 Unloader
 Fast unloader
 Oil pump (OPTIONAL)
 Oil heater (OPTIONAL)
 Liquid line solenoid (OPTIONAL)
 Hot gas bypass (OPTIONAL)
 Liquid injection (OPTIONAL)
 Second liquid line solenoid (OPTIONAL)
 Oil equalization (OPTIONAL)
 Oil seal cooler (OPTIONAL)
 VI increase valve % (OPTIONAL)
 VI decrease valve % (OPTIONAL)
 Start unloader by pass (OPTIONAL)
 Low disc super heat (OPTIONAL)
 Hot gas reheat off (OPTIONAL) If hot gas reheat all 3 relays are required.
 Hot gas reheat on (OPTIONAL)
 Hot gas reheat bleed (OPTIONAL)
 Third liquid line solenoid (OPTIONAL)
 Reversing valve (heat pump) (OPTIONAL)
 Liquid injection #2 (OPTIONAL)
 Mod motor (OPTIONAL)

16.3.6. Bitzer Screw

Compressor relay
 Part winding compressor relay (OPTIONAL)
 Loader
 Unloader
 Oil pump (OPTIONAL)
 Oil heater (OPTIONAL)
 Liquid line solenoid (OPTIONAL)
 Hot gas bypass (OPTIONAL)
 Liquid injection (OPTIONAL)
 Second liquid line solenoid (OPTIONAL)
 Oil equalization (OPTIONAL)
 Oil seal cooler (OPTIONAL)
 VI increase valve % (OPTIONAL)
 VI decrease valve % (OPTIONAL)
 Start unloader by pass (OPTIONAL)
 Low disc super heat (OPTIONAL)
 Hot gas reheat off (OPTIONAL) If hot gas reheat all 3 relays are required.

Hot gas reheat on (OPTIONAL)
Hot gas reheat bleed (OPTIONAL)
Third liquid line solenoid (OPTIONAL)
Reversing valve (heat pump) (OPTIONAL)
Liquid injection #2 (OPTIONAL)
Mod motor (OPTIONAL)

16.3.7. Hartford Screw

Compressor relay
Part winding compressor relay (OPTIONAL)
Loader
Unloader
Oil pump (OPTIONAL)
Oil heater (OPTIONAL)
Liquid line solenoid (OPTIONAL)
Hot gas bypass (OPTIONAL)
Liquid injection (OPTIONAL)
Second liquid line solenoid (OPTIONAL)
Oil equalization (OPTIONAL)
Oil seal cooler (OPTIONAL)
VI increase valve % (OPTIONAL)
VI decrease valve % (OPTIONAL)
Start unloader by pass (OPTIONAL)
Low disc super heat (OPTIONAL)
Hot gas reheat off (OPTIONAL) If hot gas reheat all 3 relays are required.
Hot gas reheat on (OPTIONAL)
Hot gas reheat bleed (OPTIONAL)
Third liquid line solenoid (OPTIONAL)
Reversing valve (heat pump) (OPTIONAL)
Liquid injection #2 (OPTIONAL)
Mod motor (OPTIONAL)

16.3.8. Carlyle Screw

Compressor relay
Part winding compressor relay (OPTIONAL)
Liquid line solenoid
Hot gas bypass (OPTIONAL)
Liquid injection (OPTIONAL)
Second liquid line solenoid (OPTIONAL)
Oil equalization (OPTIONAL)
Oil seal cooler (OPTIONAL)
VI increase valve % (OPTIONAL)
VI decrease valve % (OPTIONAL)
Start unloader by pass (OPTIONAL)
Low disc super heat (OPTIONAL)
Hot gas reheat off (OPTIONAL) If hot gas reheat all 3 relays are required.
Hot gas reheat on (OPTIONAL)
Hot gas reheat bleed (OPTIONAL)
Third liquid line solenoid (OPTIONAL)
Reversing valve (heat pump) (OPTIONAL)

Liquid injection #2 (OPTIONAL)
 Mod motor (OPTIONAL)

16.3.9. Hanbell-Load NO

Compressor relay
 Part winding compressor relay (OPTIONAL)
 Loader
 Unloader
 Oil pump (OPTIONAL)
 Oil heater (OPTIONAL)
 Liquid line solenoid (OPTIONAL)
 Hot gas bypass (OPTIONAL)
 Liquid injection (OPTIONAL)
 Second liquid line solenoid (OPTIONAL)
 Oil equalization (OPTIONAL)
 Oil seal cooler (OPTIONAL)
 VI increase valve % (OPTIONAL)
 VI decrease valve % (OPTIONAL)
 Start unloader by pass (OPTIONAL)
 Low disc super heat (OPTIONAL)
 Hot gas reheat off (OPTIONAL) If hot gas reheat all 3 relays are required.
 Hot gas reheat on (OPTIONAL)
 Hot gas reheat bleed (OPTIONAL)
 Third liquid line solenoid (OPTIONAL)
 Reversing valve (heat pump) (OPTIONAL)
 Liquid injection #2 (OPTIONAL)
 Mod motor (OPTIONAL)

16.3.10. Hanbell-Load NC

Compressor relay
 Part winding compressor relay (OPTIONAL)
 Loader
 Unloader
 Oil pump (OPTIONAL)
 Oil heater (OPTIONAL)
 Liquid line solenoid (OPTIONAL)
 Hot gas bypass (OPTIONAL)
 Liquid injection (OPTIONAL)
 Second liquid line solenoid (OPTIONAL)
 Oil equalization (OPTIONAL)
 Oil seal cooler (OPTIONAL)
 VI increase valve % (OPTIONAL)
 VI decrease valve % (OPTIONAL)
 Start unloader by pass (OPTIONAL)
 Low disc super heat (OPTIONAL)
 Hot gas reheat off (OPTIONAL) If hot gas reheat all 3 relays are required.
 Hot gas reheat on (OPTIONAL)
 Hot gas reheat bleed (OPTIONAL)
 Third liquid line solenoid (OPTIONAL)
 Reversing valve (heat pump) (OPTIONAL)
 Liquid injection #2 (OPTIONAL)
 Mod motor (OPTIONAL)

16.3.11. Hanbell- 3 Solenoid

Compressor relay
Part winding compressor relay (OPTIONAL)
Loader
Unloader
Fast unloader
Oil pump (OPTIONAL)
Oil heater (OPTIONAL)
Liquid line solenoid (OPTIONAL)
Hot gas bypass (OPTIONAL)
Liquid injection (OPTIONAL)
Second liquid line solenoid (OPTIONAL)
Oil equalization (OPTIONAL)
Oil seal cooler (OPTIONAL)
VI increase valve % (OPTIONAL)
VI decrease valve % (OPTIONAL)
Start unloader by pass (OPTIONAL)
Low disc super heat (OPTIONAL)
Hot gas reheat off (OPTIONAL) If hot gas reheat all 3 relays are required.
Hot gas reheat on (OPTIONAL)
Hot gas reheat bleed (OPTIONAL)
Third liquid line solenoid (OPTIONAL)
Reversing valve (heat pump) (OPTIONAL)
Liquid injection #2 (OPTIONAL)
Mod motor (OPTIONAL)

16.3.12. Centrifugal

Compressor relay
Part winding compressor relay (OPTIONAL)
Loader
Unloader
Oil pump
Oil heater
Liquid line solenoid (OPTIONAL)
Hot gas bypass (OPTIONAL)
Liquid injection (OPTIONAL)
Fast unloader (OPTIONAL)
Second liquid line solenoid (OPTIONAL)
Oil equalization (OPTIONAL)
Oil seal cooler (OPTIONAL)
Liquid injection #2 (OPTIONAL)
Mod motor (OPTIONAL)

16.3.13. Mitsubishi Screw

Compressor relay
Part winding compressor relay (OPTIONAL)
Fast unloader
40 % open
70 % open
Liquid line solenoid (OPTIONAL)
Liquid line solenoid (OPTIONAL)

Hot gas bypass (OPTIONAL)
 Liquid injection (OPTIONAL)
 Second liquid line solenoid (OPTIONAL)
 Oil equalization (OPTIONAL)
 Oil seal cooler (OPTIONAL)
 VI increase valve % (OPTIONAL)
 VI decrease valve % (OPTIONAL)
 Start unloader by pass (OPTIONAL)
 Low disc super heat (OPTIONAL)
 Hot gas reheat off (OPTIONAL) If hot gas reheat all 3 relays are required.
 Hot gas reheat on (OPTIONAL)
 Hot gas reheat bleed (OPTIONAL)
 Third liquid line solenoid (OPTIONAL)
 Reversing valve (heat pump) (OPTIONAL)
 Liquid injection #2 (OPTIONAL)
 Mod motor (OPTIONAL)

16.3.14. TubroCor

16.3.15. Trane Screw

16.3.16. McQuay Frame 4

Compressor relay
 Part winding compressor relay (OPTIONAL)
 Loader
 Unloader
 Oil pump (OPTIONAL)
 Oil heater (OPTIONAL)
 Liquid line solenoid (OPTIONAL)
 Hot gas bypass (OPTIONAL)
 Liquid injection (OPTIONAL)
 Second liquid line solenoid (OPTIONAL)
 Oil equalization (OPTIONAL)
 Oil seal cooler (OPTIONAL)
 VI increase valve % (OPTIONAL)
 VI decrease valve % (OPTIONAL)
 Start unloader by pass (OPTIONAL)
 Low disc super heat (OPTIONAL)
 Hot gas reheat off (OPTIONAL) If hot gas reheat all 3 relays are required.
 Hot gas reheat on (OPTIONAL)
 Hot gas reheat bleed (OPTIONAL)
 Third liquid line solenoid (OPTIONAL)
 Reversing valve (heat pump) (OPTIONAL)
 Liquid injection #2 (OPTIONAL)
 Mod motor (OPTIONAL)

16.3.17. Fu Sheng

Compressor relay
 Part winding compressor relay (OPTIONAL)
 Loader
 Unloader

- Oil pump (OPTIONAL)
- Oil heater (OPTIONAL)
- Liquid line solenoid (OPTIONAL)
- Hot gas bypass (OPTIONAL)
- Liquid injection (OPTIONAL)
- Second liquid line solenoid (OPTIONAL)
- Oil equalization (OPTIONAL)
- Oil seal cooler (OPTIONAL)
- VI increase valve % (OPTIONAL)
- VI decrease valve % (OPTIONAL)
- Start unloader by pass (OPTIONAL)
- Low disc super heat (OPTIONAL)
- Hot gas reheat off (OPTIONAL) If hot gas reheat all 3 relays are required.
- Hot gas reheat on (OPTIONAL)
- Hot gas reheat bleed (OPTIONAL)
- Third liquid line solenoid (OPTIONAL)
- Reversing valve (heat pump) (OPTIONAL)
- Liquid injection #2 (OPTIONAL)
- Mod motor (OPTIONAL)

16.4. Compressor Options

- Four compressor steps per circuit can be supported. Compressor plus three additional steps of either compressors or unloaders and hot gas bypass points. Note, compressor safeties relate to a circuit. If multiple compressors are on a circuit and a safety trips, all compressor on that circuit will be turned off. If hot gas bypass refer to Hot Gas Bypass Option.
- Specify that part winding, two RO points will be used with fixed step compressors, the first RO will be turned on with the second RO being turn on the number of seconds later that is specified in set point #73. (By circuit) If not part winding, only allocate one RO point for the compressor.
- Pump down of the compressor will be occur when the compressor is being turned off and started.. Note, when the compressor is started the liquid line solenoid is not opened until the suction pressure reaches the value that is contained in the pump down set point or the Pump Down delay set point time is exceeded. A liquid line solenoid is required for the pump down to be done. (All circuits)
- The liquid line solenoids may be eliminated. This is indicated in the circuit section in **MCS-Config** program.

16.5. Condenser Types

The type of condenser is selected form the Condenser Information section under the MAG CHL button. The type is selected from a drop down menu. Based upon the type-selected addition cells may appear in this screen.

16.5.1. Common Terms

Information that relates to condensers on the circuit						
# Cond Faults	Cond Fan Bank	Condenser Coil Temp #1	Condenser Coil Temp #2	Tandem EXV Circuit #	EXV Control	Suction Group
0	1	Not Used	Not Used	1	Superht	1
0	2	Not Used	Not Used	2	Superht	2

Condenser Fan Bank:

Grouping different circuits that share common condenser fans.

Suction Group:

Grouping different circuits with those that are on a common suction line.

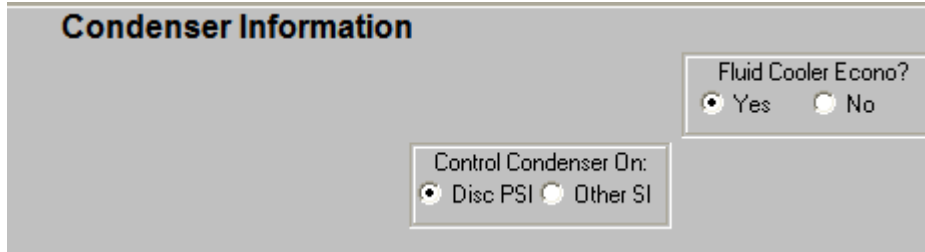

Fluid Cooler Econo?:

Option to enable the fluid cooler/economizer function to use condenser fans or VFD.

Control Condenser On (Disc PSI):

Option to enable to control fans on a compressor’s discharge pressure or other sensor. If other is chosen the sensor must be selected. In the above example, discharge pressure control is selected.

The system will check for the compressor with the highest discharge and use that as the controlling pressure.

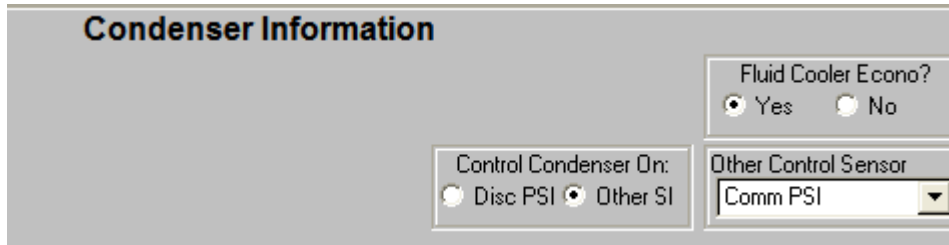

Control Condenser On (Other SI):

In above example the Other SI option is chosen. The system will not check for the compressor with the high discharge but will always use the value of the sensor that is selected as the control.

16.5.2. Develop the Control Discharge Pressure

If control is based on discharge pressure, all types of condenser develop the control discharge pressure in the following fashion. They will use this control discharge pressure to control their type of condenser.

For circuits within the same fan bank or suction group, the compressor with the highest discharge pressure will be held as the control pressure. The compressors do not have to be running!

Unless there is a compressor within the same fan bank but not in the same suction group that is in a start up mode. Start up mode is when the compressor has been on for less than 5 minutes and its discharge pressure is less than the value of set point #45,CND STG1 ON, minus the value of set point #47, CND DIFF ON. If a compressor is in start up mode, its discharge pressure will be held as the control pressure. This will enable the compressor to build up head pressure.

Unless there is a compressor within same fan bank whose discharge pressure is greater than the value of set point #81, HI DISCH PSI, minus the value of set point #83, HI DISCH UNLD. This will enable the compressor that is approaching a high discharge pressure safety to use its discharge pressure as the control discharge pressure.

If control is based on Other SI, the value of that sensor is always used as the control discharge pressure.

16.5.3. Condenser Related Set Points

45	CND STG1 ON	Air cooled- When the discharge pressure is above this value; turn on the first stage of the condenser fans.
46	CND STG1 OFF	Air cooled- If stage 1 is on and the discharge pressure drops below this value turn off the first stage of condenser fans.
47	CND DIFF ON	Air cooled- Differential PSI to turn on the remaining stages of condenser fans.
48	CND DIFF OFF	Air cooled- Differential PSI to turn off the remaining stages of condenser fans.
48	DUAL PSI DELTA	Dual V8 – Difference in pressure before stage 2 can be entered.
49	CND MIN RUN	Air cooled- Once a condenser fan stage has been turned on; it will remain on for at least the amount of minutes specified in this set point.
49	DUAL TIME DELAY	Dual V8 – Time delay once the pressure difference as been reached before stage 2 can be entered.
50	CND VLV TARG	Water cooled- Target discharge pressure to maintain by integration and Rate of Change logic.
51	CND VLV DIV	Water cooled- Usually 1. Allows control of the amount the valve is adjusted. The larger the number the smaller the valve adjustment.
52	CND VLV MIN	Water cooled- Minimum valve opening percentage allowed.
53	CND VLV ROC-	Water cooled- Maximum negative discharge pressure Rate of Change allowed. If the actual rate of change is less then this set point then stop opening the valve. The absolute value of this set point also severs as the maximum positive rate of change allowed. If the actual rate of changes is greater than the absolute value of this set point then stop closing the valve.
54	CND MIN SPD	Minimum speed percentage for variable speed condenser control.
55	CND MAX SPD	Maximum speed percentage for variable speed condenser control.

16.5.4. No Condenser Type

Condenser Information

Condenser Type

No Condenser
▼

Fluid Cooler Econo?

Yes
 No

This option indicates there is no condenser associated with this unit.

16.5.5. RO Step Common Type Without a Fan AO

Condenser Information				
Condenser Type RO Step Common	Starting Cond RelayOutput FAN 1	# of Cond Stages 3	Fan AO Not Used	Fluid Cooler Econo? <input type="radio"/> Yes <input checked="" type="radio"/> No
Cond Starting Fault Not Used	# of Cond Fault 0	Sump Temp SI Not Used	Control Condenser On: <input checked="" type="radio"/> Disc PSI <input type="radio"/> Other SI	

The RO Step Common type of condenser has one bank of fans. All circuits will use this bank of fans; make sure that all circuits in the Circuit Base point to the same common fan bank. The above example does not have a Fan AO and there are three stages of fans starting with FAN 1 relay. All stages must be consecutive relay outputs.

For example:

Set Point #	Name	Value
45	CND STG1 ON	200.0P
46	CND STG2 OFF	170.0P
47	CND DIFF ON	15.0P
48	CND DIFF OFF	5.0P
49	CND MIN RUN	1

Discharge control pressure is 200.0 P, FAN 1, first condenser stage. (Refer to discussion on developing the discharge control pressure.)

If control pressure is equal to or greater than 215.0 P then the second stage will be turned on. $(200.0 + (15.0 * 1))$

If control pressure is equal to or greater than 230.0 P then the third stage will be turned on. $(200.0 + (15.0 * 2))$

Discharge control pressure is above 230.0 P; all three condenser stages are on.

When the control pressure drops to 180.0P the third condenser stage will be turned off. $(170.0 + (5.0 * 2))$

When the control pressure drops to 175.0P the second condenser stage will be turned off. $(170.0 + (5.0 * 1))$

When the control pressure drops to 170.0P the first condenser stage will be turned off. (170.0)

Condenser Faults

This example has no condenser faults. If used and any one of the digitals are on for the time specified in set point #90 and this set point must also be active the unit will be placed in a lockout state, "UNIT IN LOCKOUT " and an alarm message will be generated.

16.5.6. RO Step Common Type With a Fan AO & Condenser Faults

Condenser Information				
Condenser Type RO Step Common	Starting Cond RelayOutput FAN 1	# of Cond Stages 3	Fan AO FANspeed	Fluid Cooler Econo? <input type="radio"/> Yes <input checked="" type="radio"/> No
Cond Starting Fault FANfault	# of Cond Fault 2	Sump Temp SI Not Used	Control Condenser On: <input checked="" type="radio"/> Disc PSI <input type="radio"/> Other SI	

The above example is the same as the previous example with the addition of a Fan AO and two condenser faults.

FAN AO CONTROL (fan control will be the same for all types of condenser air control)

Use the same set points plus two additional are needed to control the speed of the fan.

Set Point #	Name	Value
54	CND MIN SPD	20.0%
55	CND MAX SPD	100.0%

FAN 1 will be turned on when the control pressure is equal to or greater than 200.0, same as in previous example. At this point the Fan AO speed will be set to its maximum value, set point #55. If the pressure changes between 170.0 and 214.9 the fan speed will also be changed proportionally between its maximum and minimum settings. If the pressure is at 185.0 the fan speed will be set to 61.2%. If the pressure is at 190.0 the fan speed will increase to 75.0%. This will provide additional control in maintaining the discharge pressure.

If the pressure increases to 215.0 the condensers second stage will be turned on and the fan speed will also be at 100.0%. . If the pressure changes between 175.0 and 229.9 the fan speed will also be changed proportionally between its maximum and minimum settings.

If the pressure increases to 230.0 the condensers third stage will be turned on and the fan speed will also be at 100.0%. . If the pressure changes between 180.0 and 229.9 the fan speed will also be changed proportionally between its maximum and minimum settings. If the pressure is at 230.0 and above the fan speed will be at 100.0%.

As the pressure decreases toward a cutout point the fan speed decreased toward its minimum setting. Once a stage is turn of the fan speed will be set to 100.0% and again it will be modulated based upon the pressure.

Condenser Faults

This example has two condenser faults. They must be consecutive digital input types starting with FANfault. If either of these digitals are on for the time specified in set point #90 and this set point must also be active the **unit** will be placed in a lockout state, "UNIT IN LOCKOUT " and an alarm message will be generated.

16.5.7. RO Step Individual Type

Condenser Information

Condenser Type

RO Step Individual

Fluid Cooler Econo?

Yes No

Control Condenser On:

Disc PSI Other SI

The RO Step Individual has a bank of fans for each circuit. The number and location of the fan are specified under the Circuit Base button.

	(1)	(2)	(3)	(4)	(5)	(6)	Information that relates to condensers on the circuit					
	Circuit # (reset button)	# of Cond ROs	Starting Condensor RO	Condensor Fan AO	Starting Condenser Fault	# Cond Faults	Cond Fan Bank	Condenser Coil Temp #1	Condenser Coil Temp #2	Tandem EXV Circuit #	EXV Control	Suction Group
▶	1	4	FAN A&B	Not Used	Not Used	0	1	Not Used	Not Used	1	Superht	1
	2	4	FAN K&L	Not Used	Not Used	0	2	Not Used	Not Used	2	Superht	2
	3	0	Not Used	Not Used	Not Used	0	3	Not Used	Not Used	3	Superht	3
	4	0	Not Used	Not Used	Not Used	0	4	Not Used	Not Used	4	Superht	4
	5	0	Not Used	Not Used	Not Used	0	5	Not Used	Not Used	5	Superht	5
	6	0	Not Used	Not Used	Not Used	0	6	Not Used	Not Used	6	Superht	6
	7	0	Not Used	Not Used	Not Used	0	7	Not Used	Not Used	7	Superht	7
	8	0	Not Used	Not Used	Not Used	0	8	Not Used	Not Used	8	Superht	8

The above example has 2 circuits.

- (1) With each circuit having 4 fans.
- (2) The first fan for circuit 1 is FAN A&B; the other 3 fans must follow in consecutive positions. The first fan for circuit 2 is FAN K&L; the other 3 fans must follow in consecutive positions. Note, the number of fans in each circuit does not have to be the same but the condenser fan bank must be different.
- (3) There is no condenser fan AO. If a condenser fan AO was specified it would function as described in the example of the RO common with a condenser fan AO and condenser faults.
- (4) & (5) There are no condenser faults. If there were condenser faults they would function as described in the example of the RO common with a condenser fan AO and condenser faults.
- (6) Each circuit has a different fan bank.

Each circuit fan bank is controlled individually. The control discharge pressure is developed for each circuit.

The fans in each bank are staged on and off in the same matter as described in above example, RO Step Common with out a Fan AO.

Condenser Faults

This example has no condenser faults. If used and any one of the digitals are on for the time specified in set point #90 and this set point must also be active the **associated circuit** will be placed in a lockout state, "CMP LOCKED OUT" and an alarm message will be generated.

16.5.8. RO Step Combined Type

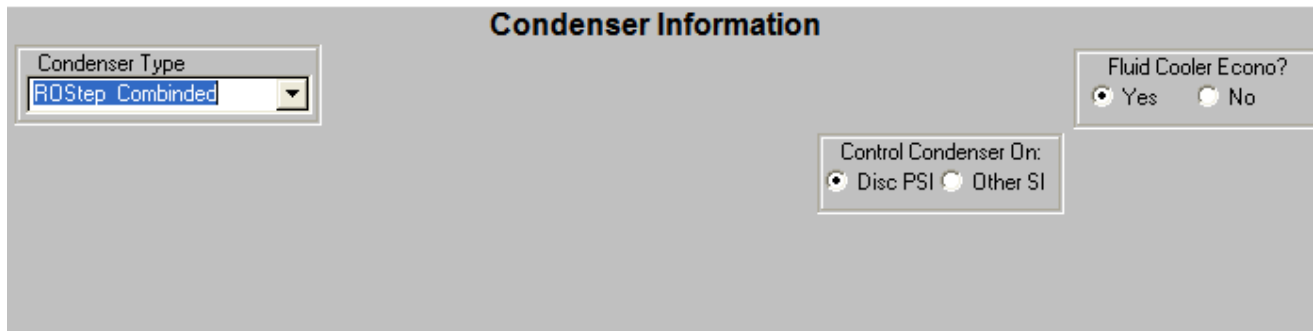

The RO Combined type has a bank of fans that are used by two consecutive circuits. The number and location of the fans are specified under the Circuit Base button. This is same as the RO Step Individual set up except only every other circuit has a condenser fans associated with it.

Information that relates to condensers on the circuit												
Circuit # (reset button)	# of Cond ROs	Starting Condensor RO	Condensor Fan AO	Starting Condensor Fault	# Cond Faults	Cond Fan Bank	Condenser Coil Temp #1	Condenser Coil Temp #2	Tandem EXV Circuit #	EXV Control	Suction Group	
1	4	FAN1&2-1	Not Used	Not Used	0	1	Not Used	Not Used	1	Superht	1	
2	0	Not Used	Not Used	Not Used	0	1	Not Used	Not Used	2	Superht	2	
3	4	FAN3&4-1	Not Used	Not Used	0	3	Not Used	Not Used	3	Superht	3	
4	0	Not Used	Not Used	Not Used	0	3	Not Used	Not Used	4	Superht	4	

Circuit one & two will share the fan bank that is specified in the circuit one grid under the Circuit Base button. The highest pressure between these two circuits will be used as the control discharge pressure for this bank of fans. These two circuits should have the same fan bank.

Circuit three & four will share the fan bank that is specified in the circuit two grid under the Circuit Base button. The highest pressure between these two circuits will be used as the control discharge pressure for this bank of fans. These two circuits should have the same fan bank.

Condenser Faults

This example has no condenser faults. If used and any one of the digitals are on for the time specified in set point #90 and this set point must also be active the **associated circuit** will be placed in a lockout state, "CMP LOCKED OUT" and an alarm message will be generated.

16.5.9. Modulating Common Type

This type of condenser uses water to provide cooling to the compressors. All circuits should have the same condenser fan bank to insure that the proper control discharge pressure is developed. The AO Modulating Valve will modulate the cold water based upon this discharge pressure.

The following applies to both the modulating common and individual water condenser types.

The valve opening percentage can be specified when all of the associated compressors are off. By selecting the default valve opening %, the valve can be completely closed, 0%; the value of set point #52 or completely open, 100% if the Run/Stop indicator is on.

This type uses the following set points:

#	NAME	DESCRIPTION
48	CND DELAY	Water cooled- if active, this is the time in seconds between adjustments to the water valve. If inactive, then 30 seconds will be used as the delay.
49	CND VLV START	Water cooled- If the valve opening is less than set point 52 and this set point is active; make the valve opening equal to this set point. This enables minimum opening to be set at larger opening percentage.
50	CND VLV TARG	Water cooled- Target discharge pressure to maintain by integration and Rate of Change logic.
51	CND VLV DIV	Water cooled- Usually 1. Allows scaling of the amount the valve is adjusted. The larger the number the smaller the valve adjustment as the adjustment will be divided by this value.
52	CND VLV MIN	Water cooled- Minimum valve opening percentage allowed.
53	CND VLV ROC-	Water cooled- Maximum negative discharge pressure Rate of Change allowed. If the actual rate of change is less then this set point then stop opening the valve. The absolute value of this set point also serves as the maximum positive rate of change allowed. If the actual rate of changes is greater than the absolute value of this set point then stop closing the valve.
54	CND VLV MULT	Water cooled- Allows scaling of the amount the valve is adjusted. The larger the number the larger the valve adjustment as the adjustment will be multiplied by this value.

The control discharge pressure will be developed. All circuit fan banks must be the same. This will develop the compressor that needs the condenser cooling.

The delay timer, set point #48 will be decremented by 4 if the control discharge pressure is more than 20.0 PSI or 2.0 bar from the target set point #50; if the difference is less but greater than 15.0 PSI or 1.5 bar the delay will be decremented by 2 else it is decremented by 1.

Delay is zero and compressor is running develop the valve adjustment value. Adjustment is equal to the absolute control discharge pressure minus set point #50 multiplied by set point # 54 and then divided by set point #51.

The system then determines where the control discharge pressure is in relation to the target, set point #50 and how fast the pressure is changing.

If the control discharge pressure is greater than set point #50 plus 5.0 PSI or .5 bar (above the zone): If the control discharge pressure change is decreasing (current value – previous value) more than twice the value of set point #53 then the pressure is dropping too fast – close the valve by the calculated adjustment. If the control discharge pressure change is increasing (current value – previous value) more than the value of set point #53 then the pressure is decreasing too slow – open the valve by the calculated adjustment. Else make no adjustment at this time.

If the control discharge pressure is less than set point #50 minus 5.0 PSI or .5 bar (below the zone): If the control discharge pressure change is increasing (current value – previous value) more than twice the value of set point #53 and the control discharge pressure is greater than set point #50.0 minus 20.0 PSI or 1.3 bar then the pressure is increasing too fast – close the valve by the calculated adjustment. If the control discharge pressure change is increasing (current value – previous value) more than the value of set point #53 then the pressure is increasing too slow – open the valve by the calculated adjustment. Else make no adjustment at this time. Else make no adjustment at this time.

If the control discharge pressure is with in the zone: If the control discharge pressure change is increasing (current value – previous value) more than the value of set point #53 then close the valve by 1 percent. If the control discharge pressure change is decreasing (current value – previous value) more than the value of set point #53 then open the valve by 1 percent.

16.5.10. Modulating Individual Type

Condenser Information

Condenser Type: Modulating Individual

Fluid Cooler Econo? Yes No

Control Condenser On: Disc PSI Other SI

Default Valve Opening % when Comp. is OFF: 0% Valve % defined by Setpoint #52 100% when Run/Stop = ON else = 0%

This type of condenser uses water to provide cooling to the compressors. The AO Modulating Valve will modulate the cold water based upon this discharge pressure.

The individual condenser must be set up in the Circuit Base screen.

Information that relates to condensers on the circuit												
Circuit # (reset button)	# of Cond ROs	Starting Condensor RO	Condensor Fan AD	Starting Condensor Fault	# Cond Faults	Cond Fan Bank	Condenser Coil Temp #1	Condenser Coil Temp #2	Tandem EXV Circuit #	EXV Control	Suction Group	
1	...	1	CND ON1	CNDvlv1	Not Used	0	1	Not Used	Not Used	1	Superht	1
2	...	1	CND ON2	CNDvlv2	Not Used	0	2	Not Used	Not Used	2	Superht	2

The control will be the same as in the Modulating Common type except that the control discharge pressure will be developed for each circuit.

Condenser Faults

This example has no condenser faults. If used and any one of the digitals are on for the time specified in set point #90 and this set point must also be active the **associated circuit** will be placed in a lockout state, "CMP LOCKED OUT" and an alarm message will be generated.

16.5.11. RO Shared Type

Condenser Information

Condenser Type

RO Shared(CHL R)

Fluid Cooler Econo?

Yes No

Control Condenser On:

Disc PSI Other SI

The RO Shared type has a bank of fans that are shared between two consecutive circuits. The number and location of the fan are specified under the Circuit Base button. This is similar to the RO Step Individual set up.

Circuit one & two will share the fan bank that is specified in the circuit one grid under the Circuit Base button. The highest pressure between these two circuits will be used as the control discharge pressure for this bank of fans.

Circuit two & three will share the fan bank that is specified in the circuit two grid under the Circuit Base button. The highest pressure between these two circuits will be used as the control discharge pressure for this bank of fans.

In a unit with three circuits, circuit three will not have a fan bank associated with it. It shares circuit 2's fan bank.

Note, the last circuit will not be checked as it has no fans associated with it.

Condenser Faults

This example has no condenser faults. If used and any one of the digitals are on for the time specified in set point #90 and this set point must also be active the **associated circuit** will be placed in a lockout state, "CMP LOCKED OUT" and an alarm message will be generated.

16.5.12. Dual V8 Type

Condenser Information				
Condenser Type Dual V8	Starting Cond RelayOutput CNDstge1	# of Cond Stages 2	Fan AO CNDspeed	Fluid Cooler Econo? <input type="radio"/> Yes <input checked="" type="radio"/> No
Cond Starting Fault Not Used	# of Cond Fault 0	Sump Temperature Not Used	Control Condenser On: <input checked="" type="radio"/> Disc PSI <input type="radio"/> Other SI	

This is a special type of condenser. It is a common air type that has two stages of fans plus Fan VFD. The control of the fan speed will be different depending on whether one or two stages are on. All compressors are checked to develop the control discharge pressure. All circuits should be in the same fan bank.

A compressor must be running and the delay counter, set point #49, has counted down to zero before the system will check to determine the status of this type of condenser.

If the control discharge pressure is less than set point #45 both condenser stages are off and the fan speed is zero.

If the control discharge pressure is greater than set point #45 and less than set point #46 stage 1 will be on. The fan speed will be equal the value of (set point #55 minus set point #54) divided by (set point #46 minus set point #45) this will be multiplied by (control discharge pressure minus set point #46) plus set point #54.

If the control discharge pressure increases while in stage 1 above the value of set point #46 plus set point #48 for the time contain in set point #49 stage 2 will be entered. Both relays will be on and the fan speed will be equal the value of (set point #55 minus set point #54) divided by set point #46 this will be multiplied by (control discharge pressure minus set point #46) plus set point #54.

If the speed of the condenser fan is less than set point #54 it will be set to that value or if the speed of the condenser fan is greater than set point #55 it will be set to that value.

16.5.13. Common VFD Fan w/Bypass Type

Condenser Information				
Condenser Type Common VFD Fan w/ Byp	Starting Cond RelayOutput VFD LOAD	# of Cond Stages 1	Fan AO VFD	Fluid Cooler Econo? <input type="radio"/> Yes <input checked="" type="radio"/> No
Cond Starting Fault VFD FAIL	# of Cond Fault 1	Sump Temp SI Not Used	Control Condenser On: <input checked="" type="radio"/> Disc PSI <input type="radio"/> Other SI	

The Common VFD Fan with a Bypass type of condenser has one fan. All circuits will use this fan; make sure that all circuits in the Circuit Base point to the same common fan bank. The above setup shows that there is one condenser stage. However this type requires the following three consecutive relay outputs to be set up. For example:

1-6	...	VFD LOAD
1-7	...	VFD BYPS
1-8	...	VFD ENAB

This type of condenser requires one condenser fault. If the fault occurs then the VFD will be by passed and the fan will run at 100% if needed.

The following set points will be used.

45	CND STG1 ON	Air cooled- When the discharge pressure is above this value; turn on the first stage of the condenser fans.
46	CND STG1 OFF	Air cooled- If stage 1 is on and the discharge pressure drops below this value turn off the first stage of condenser fans.
54	CND MIN SPD	Minimum speed percentage for variable speed condenser control.
55	CND MAX SPD	Maximum speed percentage for variable speed condenser control.
90	COND FAULT	Time in seconds for the delay before the by pass can be used when a fault has occurred for a condenser type of Common VFD Fan w/Bypass.

Fan control when there is no fault:

The control discharge pressure is developed based upon all compressors.

The first relay, VFD LOAD, is on and the second relay, VFD BYPS, is off.

When the control discharge pressure is greater than the value of set point #45 the third relay, VFD ENAB, will be turned on and the VFD will be set to the value of set point #55. If the control discharge pressure decreases the VFD will be modulated between set points #54 and #55 based upon the control discharge pressure.

Assume set point values

45	CND STG1 ON	250.0P
46	CND STG1 OFF	170.0P
54	CND MIN SPD	20.0%
55	CND MAX SPD	100.0%
90	COND FAULT	30s

When the discharge control pressure is greater than 250.0P the relay VFD ENAB will be on and the VFD on the fan will be set to 100.0%.

If the discharge control pressure drops to 210.0 the fan speed will be set to 60.0%. The discharge control pressure is half of its cut in and cut out range ($250.0 - 170.0 = 80.0 / 2 = 40.0 = 170.0 + 40.0 = 210.0$) therefore, the VFD will be positioned to half of its range ($100.0 - 20.0 = 80.0 / 2 = 40.0 + 20.0 = 60.0$).

The VFD will continue to be modulated in this manner until the discharge control pressure drops below 170.0. If this happens the VFD will be at 0.0% and relay VFD ENAB will remain on. If the pressure goes above 170.0 the VFD will be modulated. For example if the discharge control pressure goes to 190.0 the VFD will be set to 50.0%.

Fan control when there is a fault:

If a fault occurs, an alarm message will be generated, relay VFD LOAD will be turned off and its state will be LOCKOFF, relay VFD ENAB will be off, the VFD speed will be set to 0% and the by pass, VFD BYPS, will be enabled if needed after waiting for 30 seconds, set point #90. Once the fan bypass is enabled and the discharge control pressure goes above 250.0 the by pass will be turned on enabling the fan to run at 100.0% and it will remain on regardless of the discharge control pressure.

If the fault resets it self, no longer on, the state of VFD LOAD will be set to AUTO, the VFD BYPS relay will be turned off and VFD will be enabled to control the fan speed if it is needed.

16.6. Chiller Barrel Heater Options

- Chiller Barrel Heater, if specified a heater for the chiller barrel will be controlled based upon ambient temperature and set point #134, BARREL HEATER.

16.7. Hot Gas Bypass (Screw Chillers)

Will be turned on/off depending on pressure and/or temperature if the appropriate set points are active.

LEAVING LIQUID SET POINTS (LLSP) & LOW SUCTION SET POINTS INACTIVE (LSSP)-

If both set points are inactive the HGB is enabled when the machine is unloaded to within 25% of the minimum slide percentage.

LEAVING LIQUID SET POINTS ACTIVE-

If the LLSP is active the HGB is on when the machine is unloaded & the leaving liquid goes below the LLSP cut in. HGB is turned off when the HGB is on and the leaving liquid temperature goes above the LLSP cutout or the machine leaves the unloaded state.

HGB SUCTION SET POINTS ACTIVE-

If the LSSP is active the HGB is on when the machine is unloaded & the suction pressure goes below the LSSP cut in. HGB is turned off when the HGB is on and the suction pressure goes above the LSSP cutout or the machine leaves the unloaded state.

LEAVING LIQUID SET POINTS (LLSP) & LOW SUCTION SET POINTS ACTIVE (LSSP)-

If both set points are active the HGB is on when the machine is unloaded and either the leaving liquid temperature goes below the LLSP cut in or the suction pressure goes below the LSSP cut in. The HGB goes off when the machine leaves the unloaded state or both the leaving liquid temperature goes above the LLSP cutout and the suction pressure goes above the LSSP cutout.

16.8. Chilled Water Reset

Chilled Water Reset (CWR) is a 0 to 5 volts dc sensor input; Display Type is TRGTRST, to the MCS microprocessor. The CWR follows the following rules using set point #21, MAX TRG RESET:

1. If the input is 2.5 volts dc the CWR is zero.
2. At 0 volts dc the CWR is a negative value equal to the set point value.
3. At 5.00 volts dc the CWR is a positive value equal to the value in the set point.
4. For values in between 0 – 2.5 and 2.5 – 5.0 the CWR is a plus or minus value which is proportional to the sensor input voltage.

16.9. Two Expansions Valves Per Circuit Option

Two expansion valves per circuit are supported in CHL V8 software. Refer to section '**Circuit relay output sequence (examples)**' for RELAY OUTPUT order and options.

When the compressor first starts, the small LLS opens after a pre pump down. The large LLS turns on at 30 percent above unloaded amps + 5 amps. The large LLS opens based on the following calculations.

1. Using set points for full load amps & min var step calculate UNLOADED AMPS.
UNLOADED AMPS = (FULL LOAD AMPS) X (MIN VAR STEP)
2. Using set point full load amps & calculated unloaded amps calculate AMP TRAVEL 30.
AMP TRAVEL 30 = [(FULL LOAD AMPS) – (UNLOADED AMPS)] X .3
3. Using UNLOADED AMPS & AMP TRAVEL 30 calculates LLS LARGE OFF.
LLS LARGE OFF = UNLOADED AMPS + AMP TRAVEL 30
4. Using LLS LARGE OFF calculate LLS LARGE ON.
LLS LARGE ON = LLS LARGE OFF + 5

16.10. Oil Equalization Option

Oil equalization occurs with common suction/common discharge systems. This feature allows for a solenoid valve to open, allowing oil to equalize between compressors. The oil equalization occurs at a compressor starting. Refer to section **'Circuit relay output sequence (examples)'** for RELAY OUTPUT order and options.

If this feature is installed the micro will energize the Oil Equalization solenoid valve for 1 minute at the time a compressor is turned on.

16.11. Liquid Injection Option

This option is selected by accessing the Circuit Base button:

Circuit Base									
Information that relates to compressors on the circuit									
LS	3rd LLS	3rd LLS Control	Unloading Stages	Loader Type	HGB	HG Reheat	Liquid Injection		
...	No	Slide %	0	Unloader	None	No	...	No	▼
...	No	Slide %	0	Unloader	None	No	No		
...	No	Slide %	0	Unloader	None	No	1 Stage		
...	No	Slide %	0	Unloader	None	No	2 Stage		

In the Liquid Injection column check on the cell for the circuit, which will have liquid injection. A drop menu gives in the options of No, 1 Stage or 2 Stage. Select option desired.

If 2 Stage option is selected the second stage relay must follow the first stage relay.

The first stage will be turned on if either the discharge temperature is greater or equal to the discharge temperature set point #8 or suction pressure is less than the unsafe suction set point #80 plus .5 if Metric else 5.0 PSI.

If 2 Stage has been selected, the second relay will be turned on if the discharge temperature is greater or equal to the discharge temperature set point #8 plus 2.5 if Metric else 5.0 degrees and the first relay has been on for a time greater that the safety time of this set point.

If the Slide Multiple cell of relay output for the first stage of liquid injection is not equal to zero then this relay will be turned on during the fast unload logic.

16.12. Oil Cooler Option

Oil cooler option can be specified for compressors with oil. This feature requires a temperature sensor to capture the oil temperature, a relay out to energize the oil cooler and the OILCOOLER ON set point (#10) to be active. Refer to section **'Circuit relay output sequence (examples)'** for RELAY OUTPUT order and options.

If the oil temperature is above the value in the set point for longer than the time specified, the relay output is energized. The relay output will remain on until the temperature is less 5.0F degrees below the set point value.

16.13. Oil Pump Control Option

- OIL PUMP ALWAYS ON: The oil pump will always be on when the associated compressor is on. If the oil psi drops below the value of set point #74, shut down the associated compressor with a

LOW DIFFERENTIAL alarm. Keep the oil pump on after the compressor is turned off regardless of the reason, for the time specified in set point #62.

- OIL PUMP CYCLES: After the compressor has been running for 2 minutes and when the discharge psi minus the suction psi is greater than the value in set point #74 (OIL PUMP OFF) the oil pump will be turned off. If the discharge psi minus the suction psi drops 10 psi below the value of set point #74 the oil pump will be turned on.
- OIL PUMP LUBE ONLY: After the compressor has been running for 2 minutes and when the discharge psi minus the suction psi is greater than the value in set point #74 (OIL PUMP OFF) the oil pump will be turned off. If the differential psi has not been reached after 5 minutes, shut down the associated compressor with a LOW DIFFERENTIAL alarm. Once the differential psi has been reached and the oil pump turned off, if the discharge psi minus the suction psi drops 5 psi below the value of set point #74, shut down the associated compressor with a LOW DIFFERENTIAL alarm.

16.14. Oil Differential Calculation

The calculation is OIL PRESSURE minus DISCHARGE PRESSURE for chillers with external oil pumps.

For all other software the calculation is OIL PRESSURE minus SUCTION PRESSURE. This provides the flexibility of using oil pressure if available or if not, discharge pressure can be used in place of the oil pressure. This is set up in the circuit information section of **MCS-Config** by pointing the oil pressure sensor to the discharge pressure sensor. The difference between oil pressure and discharge pressure is the drop across the oil filter.

On units with both oil & discharge pressure sensors you have the ability to generate an oil filter alarm and shut down the compressor.

-

16.15. On/Off Switches

- The following digital input switches can be associated with the system, their action will affect the chiller package or an individual circuit, then action will only affect that circuit:
 - Flow switch, if off the system has lost flow. The system wills either lock out, if NO FLOW set point is active, or shut down, if NO FLOW set point is inactive.
 - Pump down switch, if on and the compressor is off, will not start the compressor. If the compressor is on, the system moves to the pump down state to begin the process of turning off the compressor(s) in normal steps.
 - Run/Stop, if off the system will not run. This is usually wired to a RUN/STOP switch that is manually positioned. If the system is running, the system moves all circuits (compressor) to off in normal steps. (If a RUN/STOP and a Network RUN/STOP are both available they operate in series.)
 - Network Run/Stop, if off the system will not run. This input is provided by another system that resides on the network. It functions in the same matter as the Run/Stop switch.
 - Emergency Stop switch, if on, the system will be shut down immediately and will remain disabled until the switch is off.

16.16. Low Suction Unloading & Holding

This option is activated when the set point #78, LO SUCT UNLD, is active. The purpose of this option is to take corrective action prior to a safety being tripped. When the suction pressure is below the value calculated by adding the value of this set point to the value of the LOW SUCTION set point for the time specified, the system will turn on the WARNING relay output if specified in the **MCS-Config** and take the following action:

- For a fixed step compressor, the system will turn off one step of capacity associated with that compressor until that circuit is in an UNLOADED state, that is all steps except one are unloaded. The circuit (compressor) state will be LO SUCT HOLD. The circuit will remain in that state until the capacity control indicates that another step is to be unloaded or if after 5 minutes the suction pressure has turned to normal.
- For an infinite step compressor, the system will begin unloading that compressor until the suction pressure rises above the calculated value. During this time the circuit (compressor) state is LO SUCT UNLOAD. Once this pressure has been reached, the circuit (compressor) state will be LO SUCT HOLD. The circuit will remain in that state until the capacity control indicates that less capacity is needed or if after 5 minutes the suction pressure has turned to normal.

Normal pressure is the value calculated by adding the value of the LO SUCT RELD set point 79 to the value of the LOW SUCTION set point 77.

Refer to set point #78 and 79 for additional information.

16.17. High Discharge Pressure Unloading & Holding

This option is activated when the set point #82, HI DISC UNLD, is active. The purpose of this option is to take corrective action prior to a safety being tripped. When the discharge pressure is above the value calculated by subtracting the value of this set point from the value of the HI DISCH PSI set point for the time specified, the system will turn on the WARNING relay output if specified in the **MCS-Config** and take the following action:

- For a fixed step compressor, the system will turn off one step of capacity associated with that compressor until that circuit is in an UNLOADED state, that is all steps except one are unloaded. The circuit (compressor) state will be HI DISC HOLD. The circuit will remain in that state until the capacity control indicates that another step is to be unloaded or if after 5 minutes the discharge pressure has turned to normal.
- For an infinite step compressor, the system will begin unloading that compressor until the discharge pressure drops below the calculated value. During this time the circuit (compressor) state is HI DISC UNLOAD. Once this pressure has been reached, the circuit (compressor) state will be HI DISC HOLD. The circuit will remain in that state until the capacity control indicates that less capacity is needed or if after 5 minutes the discharge pressure has turned to normal.

Normal pressure is the value calculated by subtracting the value of the HI DISC RELD set point 83 to the value of the HI DISC PSI set point 81.

Refer to set point #82 and 83 for additional information.

16.18. High Discharge Temperature Unloading & Holding

This option is activated when the set point #88, HI DISC UNLD, is active. The purpose of this option is to take corrective action prior to a safety being tripped. When the discharge temperature is above the value calculated by subtracting the value of this set point from the value of the HI DISCH TMP set point for the time specified, the system will turn on the WARNING relay output if specified in the **MCS-Config** and take the following action:

- For a fixed step compressor, the system will turn off one step of capacity associated with that compressor until that circuit is in an UNLOADED state, that is all steps except one are unloaded. The circuit (compressor) state will be HI DISC HOLD. The circuit will remain in that state until the capacity control indicates that another step is to be unloaded or if after 5 minutes the discharge temperature has turned to normal.
- For an infinite step compressor, the system will begin unloading that compressor until the discharge temperature drops below the calculated value. During this time the circuit (compressor) state is HI DISC UNLOAD. Once this temperature has been reached, the circuit (compressor) state will be HI DISC HOLD. The circuit will remain in that state until the capacity control indicates that less capacity is needed or if after 5 minutes the discharge temperature has turned to normal.

Normal pressure is the value calculated by subtracting the value of the HI DISC RELD set point 89 to the value of the HI DISC TMP set point 87.

Refer to set point #88 and 89 for additional information.

16.19. High Ampere Unloading & Holding

This option is activated when the set point #75, HI AMPS %, is active. This option can only be active for fixed step compressors. The purpose of this option is to take corrective action prior to a safety being tripped. When the amp draw is within one-half of the calculated HI AMP safety value, the system will turn on the WARNING relay output if specified in the **MCS-Config** and take the following action:

- For a fixed step compressor, the system will turn off one step of capacity associated with that compressor until that circuit is in an UNLOADED state, that is all steps except one are unloaded. The circuit (compressor) state will be HI AMP HOLD. The circuit will remain in that state until the capacity control indicates that another step is to be unloaded or if after 5 minutes the amp draw has turned to normal.

16.20. Low Water Temperature Unloading & Holding

The purpose of this option is to take corrective action prior to the freeze safety being tripped. When the leaving liquid temperature is within 1.5F or .8C degrees of the freeze safety, the system will turn on the WARNING relay output if specified in the **MCS-Config** and take the following action:

- For a fixed step compressor, the system will turn off one step of capacity associated with that compressor until that circuit is in an UNLOADED state, that is all steps except one are unloaded. The circuit (compressor) state will be LO TMP HOLD. The circuit will remain in that state until the capacity control indicates that another step is to be unloaded or if after 5 minutes the leaving liquid temperature has turned to normal.
- For an infinite step compressor, the system will begin unloading that compressor until the leaving liquid temperature rises above the calculated value. During this time the circuit (compressor) state is LO TMP UNLOAD. Once the leaving liquid temperature has been reached, the circuit (compressor) state will be LO TMP HOLD. The circuit will remain in that state until the capacity control indicates that less capacity is needed or if after 5 minutes the leaving liquid temperature has turned to normal.

Normal leaving liquid temperature is the value calculated by adding 3.0F or 1.6C to the freeze safety trip value.

Refer to set point #78 and 79 for additional information.

16.21. Energy Efficient Compressor Staging

In a multi-screw package, it may be more efficient to run the screws at less than 100% of their FLA until all of the screws have been turned on.

The following set points will be used to control the screw compressor staging:

- Set point #30, MAX SLIDE %, contains the maximum slide percentage, based upon amp draw, FLA before the system will bring on the next compressor.
- Set point #31, MIN SLIDE %, contains the minimum slide percentage, based upon amp draw, FLA before the system will reduce the number of compressor that are on.

For example if the MAX SLIDE % is 80% and the MIN SLIDE % is 40 a two-screw compressor system would be ramped up as follows:

The Lead compressor will be started at 40% and increased up to 80%. If more capacity is needed the next compressor will be started at 40% and the first compressor decreased to 40%. The two compressors will then have their slide positions changed together. Since there are only two compressors, they will be ramped together up to 100% if required.

If both compressors are at 40% and less capacity is needed, one compressor will be turned off and the other increased to 80%.

For example if the MAX SLIDE % is 75.0%, MIN SLIDE % is 45.0% and #102 = 2,

The system will bring on the first compressor at 45% of FLA and ramp it from 45 up to 75% of FLA. This will provide the 30 to 50% of slide movement. If more capacity is needed the second compressor will be started. Since set point #102 is equal to 2, the maximum will now be 100%; Compressors 1 and 2's slide will be varied from 45 to 100% of FLA. If more capacity is needed, a third compressor will be turned on. This will continue until all compressors are on. If less capacity is needed, compressors will be turned off in the same manner. Note: stage 1 will be varied from 45 to 75% all other stages will be varied from 45 to 100%.

This provides the user with additional capabilities in fine-tuning the efficiency of a screw compressor.

16.22. Chilled Water Pump Control

The system will support a chilled water pump plus a back up. These must be set up in the **MCS-Config** program.

If set point #105, PUMP FAILURE, is active and flow is lost and only one pump is present the system will move to a LOCK OUT state. If the system has two pumps and flow is lost the backup pump will start and the lead pump will be locked out. If the second pump is running and flow is lost then the entire system will be locked out. A lock out reset will be required to restart the system or to reactive a locked out pump.

If this set point is inactive and the flow is lost, the system will move to the OFF- NO EVAP FLOW state. When flow is returned the system will automatically restart, no reset is required.

Set point #106, LEAD PUMP, indicates which pump is the lead pump.

16.23. Process Pump & Heat Exchanger Control

The process pump is on whenever the chilled water pump is on. A control zone is developed for the process temperature by adding and subtracting the value in set point #14 (PROC ZONE) to set point #13 (PROC TARGET). The process temperature is maintained with in this zone by modulating the control valve with a 0-10Vdc analog output signal.

16.24. Control Power Relay –No Stop

This option provides the capability of interrupting the power supply to the compressors in the system. A relay output, referred to as the control relay, must be wired so that when it is off no power reaches the compressors. This is a safety measure that will insure that the compressors are off then the system calls for them to be off. The relay output must be indicated in the **MCS-Config** program and set point 112, NO STOP, must be active. The system will continually monitor the amp draw of compressors that the system has in an off state. The system will calculate the minimum amp draw by multiplying the FLA for that compressor times the percentage value in the NO STOP set point. If the amp draw is greater than this value for the time specified; the system will turn the control relay off, generate a NO STOP alarm and place the system in a lockout state. This provides an additional level of protection.

16.25. Part Wind or Star Delta Starter

Either a part winding or star delta type of compressor starter is supported. This option is specified in the **MCS-Config** program and will require two successive relay output points. When this option is specified, set point #73, STARTER DLAY, must contain the delay in seconds before the second relay output is turned on. This delay is normally 1 second for part winding or 5 seconds for a star delta starter. With this option, when a compressor is to be turned on, the first relay output is turned on and the system will wait the time specified in set point 73 before the second relay output is turned on.

16.26. Low & High Ambient Shutdown

The system supports both a low and a high ambient shut down. This option requires an ambient temperature sensor and both LOW AMB OFF set point (#24) and HIGH AMB OFF set point (#26). The AMBIENT OFF state is entered when the ambient temperature falls below the LOW AMB OFF set point (#24) or is above the HIGH AMB OFF set point (#26). The system will remain in this state until the ambient temperature rises 5.0F (or 2.5C) above the LOW AMB OFF set point value or drops 5.0F (or 2.5C) below the HIGH AMB OFF set point value. When the chiller is in this state, the individual circuit states if active are moved to the CMP IS OFF state through the normal staging function. One capacity STEP will be moved per second.

16.27. English, Metric or Mixed C/P sensor readings

The system supports English, Metric or Mixed C/P sensor readings, this is specified in the **MCS-Config** program. All sensor values and all software-coded offsets are automatically converted into the option selected and displayed with the appropriate character. The following table contains the display character:

SENSOR READING	ENGLISH CHARACTE	METRIC CHARACTE	MIXED CHARACTE
	R	R	R
Temperature	F	C	C
Pressure – Gage Reading	P	B	P
Pressure – Absolute Reading	p	b	p
Humidity	%	%	%
Digital or Switch			
Amp or CT	A	A	A
Voltage	V	V	V
Refrigeration Level	%	%	%

NOTE: If the type of display is changed, MCS-Config will give you an option to automatically change the value of all items in set points to match the new type. Their display character will be automatically adjusted.

16.28. Compressor Auto Rotation

The auto rotation option is selected by setting the value in set point #103, LEAD COMP to zero. If this value is not zero, it will contain the number of the lead circuit (compressor) and auto rotation is disabled.

Note this set point can be manually changed to force a different compressor as the lead compressor or to enable auto rotation.

When this option is enabled, the system will rotate the compressors based upon the value in set point # 104, CMP ROTATION.

If set point # 104 value is zero, rotation will occur with every complete capacity cycle and the next compressor will be selected as the lead compressor.

Else, the value is the number of days between rotations. At midnight the system will check if it is time to rotate compressors. If yes, the system will check the run hours on each compressor and select the one with the least amount of run hours to be the lead compressor.

If set point # 104 is set up as an ALARM type of set point, a compressor rotation message will be generated each time a compressor is rotated.

16.29. Compressor Anti-Cycle Logic

When a compressor is to be turned off, the system will make a calculation to determine the amount of time that the compressor shall be in an anti-cycle state. This calculation is based upon how long the compressor has been on and set points #59 (ACYC OFF->ON) and #63 (ACYC ON->ON).

If the value of set point #63 minus the amount of time that the compressor has been on is greater than the value in set point #59, the compressor will remain in the anti-cycle state for the period of time specified in set point #63. Else the anti-cycle time will be set to the value in set point #59.

For example:

A compressor has been running for 180 seconds

#59 (ANTI-CYC OFF) = 300 seconds

#63 (ANTI-CYC ON) = 600 seconds

$600 - 180 = 420$ this is greater than set point #59; therefore, the anti-cycle timer will be set to 600 seconds, the value of set point #63.

If the compressor had been running for 12 minutes (720 seconds)

$600 - 720 = -120$ this is less than set point #59; therefore, the anti-cycle timer will be set to 300 seconds, the value of set point #59.

If the controller losses power, the length of time that the system was down will be taken into consideration when determining whether the compressor should be in an anti-cycle state and for how long.

16.30. Warning & Alarm Relay Outputs

Warning Relay Output will be turned on whenever the system generates a warning type of message.

These messages are:

- LOW REFR TEMP UNLOAD
- LOW SUCT PSI UNLOAD
- HIGH DISC TEMP UNLOAD
- LOW SUCT RELOAD
- LOW DISC RELOAD
- CIRCUIT IS IN A SAFETY STATE

The system will continue to run and no safeties have been tripped.

Warning Relay Output will also be turned on whenever a circuit is placed in a safety state.

Alarm Relay Output will be turned on whenever the system generates an alarm type of message. This indicates that a safety or lockout condition has occurred.

16.31. Vi Port Control Logic (Open Drive Screw only)

The internal volume (Vi) of the open drive screw can be dynamically varied to obtain maximum efficiency by opening and closing solenoids that control the Vi. These solenoids are pulsed and the duration of each pulse is contained in set point #114 (Vi PULSE).

Calculate a ratio of discharge pressure divided by suction pressure. This ratio is blocked between 50 and 22. The value of set point #115(Vi DEADBAND) is added to and subtracted from this ratio to develop a control zone. The control zone will be recalculated based upon the time in set point #116(Vi DELAY).

The Vi reading is provided by a special sensor refer to set points #117, #118 and #119. The system will pulse the open or close solenoids to keep the Vi reading within the calculated control zone.

16.32. Operating Schedules

Two operating schedules per each day of the week and 8 holidays are supported. Each schedule contains a start and end time, if the time and day of the system is with in these limits the schedule is true and the system will be allowed to run. If not, the system will be off due to schedule.

16.33. Mod-Motor Limit Control For Flooded Chiller

This option was added for Dunham-Bush flooded chillers. The Mod-Motor is a self-contained device that modulates a valve to controls the level in a flooded chiller barrel base on a level sensor. The MAGNUM controls two relay outputs that change the limits on the movement of the Mod-Motor (The relay outputs change resistance on a input to the Mod-Motor. These relay outputs must be consecutive relays and are setup in the general section of the **MCS-Config** for CHL V8. When none or one compressor is on, the first Mod-Motor relay output is turned on and the second Mod-Motor relay output is off.

When 2 or more compressors are on, first Mod-Motor relay output is turned off. The second Mod-Motor relay output will be turned on if the suction pressure is greater than 85.0 psi (5.8 if metric) and the discharge suction pressure differential is less than 30.0 psi (2.0 if metric). Or if the second Mod-Motor relay output is already on and the suction pressure is greater than 80.0 psi (5.8 if metric) and the discharge suction pressure differential is less than 35.0 psi (2.4 if metric). If neither of the above is true, then the second Mod-Motor relay output will be turned off.

16.34. Compressor lead and Rotation

Refer to Set points #103 & #104.

16.35. Exhaust Fan

If an Exhaust Fan exists, its status will be checked every 120 seconds. It will be turned on if any of the following conditions exist:

- Exhaust fan digital input is on
- Or
- Ambient temperature is greater than the valve in set point #107. The set point must be active and a sensor input must be setup that reads the ambient temperature.

The exhaust fan will be turned off if the digital input exists, the input is off and the ambient temperature if used is 2.5°F (or .8°C) below the set point #107.

16.36. Hot Gas Reheat (Humidity) Control

To specify the Reheat option select the Circuit Base Button:

Information that relates to compressors on the circuit						
3rd LLS	3rd LLS Control	Unloading Stages	Loader Type	HGB	HG Reheat	Liquid Injection
No	Slide %	0	Unloader	None	Yes	1 Stage

Select YES in the column HG Reheat. This indicates that the circuit selected will have the necessary hot gas reheat information.

The hot gas control sensor is specified by selecting the MAG CHL Button:

Evaporator Information

Refrigerant Type R22	Lag Unit ON/OFF Relay Not Used	Entering Temperature RA TEMP	Leaving Temperature RA HUM
Flow Switch SF FLOW	Barrel Heater Relay Not Used	Pump #1 Relay REHEAT	Pump #2 Relay Not Used
Starting Process PumpRO Not Used	Temperature SI Not Used		Process Control Type <input type="radio"/> VFD (0V-10V) <input checked="" type="radio"/> ByPass Valve(10V-0V)
Process Output Type <input type="radio"/> Modulating (AO) <input checked="" type="radio"/> Staged (RO)		Reheat Control RH TEMP	Refrig Level Not Used

In the Evaporator Information Section, in the Reheat Control cell select the input sensor that will be used to control the hot gas reheat function.

When this option is selected the relay out puts must be setup as follows:

Relay Output Information Screen (Magnum)

#	Name	Max Pulses (10th Sec.)	Slide Multiple	Slide Division	Slide Offset	Design Suction PSI	Design Disc PSI	Comp EXV Adjust %	Unload EXV Adjust %	EXV off Adj % Diff
M-1	COMP 1	0	67	11	39	70	220	0	0	0
M-2	LOAD 1	0	0	0	0	0	0	0	0	0
M-3	UNLD 1	0	0	0	0	0	0	0	0	0
M-4	LSV1	0	0	0	0	0	0	0	0	0
M-5	LSVi1	0	0	0	0	0	0	0	0	0
M-6	REHEAT	0	0	0	0	0	0	0	0	0
M-7	R-Hvalve	0	0	0	0	0	0	0	0	0
M-8	R-Hbleed	0	0	0	0	0	0	0	0	0
M-9	SF MOT	0	0	0	0	0	0	0	0	0
M10	ALARM	0	0	0	0	0	0	0	0	0

The hot gas reheat relays are required and they must follow the last option selected.

The following set points must be set up:

129	RH CUTIN	Reheat cut in temperature
130	RH CUTOFF ADJ	Reheat cutout temperature is developed by adding this value to set point #129
131	RH START DLY	Reheat delay in seconds before starting
132	RH BLEED DLY	Reheat delay in seconds before starting bleeding of gas

133	RH STAGE DLY	Reheat delay in seconds before starting next stage of reheat
-----	--------------	--

Hot gas reheat sequence of operations:

(The names in the above example will be used to indicate the status of the relays: M-6 REHEAT, M-7 R-Hvalve, and M-8 R-Hbleed)

Condition	M-6 REHEAT	M-7 R-Hvalve	M-8 R-Hbleed
The reheat state is OFF. Compressor is running and the RH TEMP is greater than set point #129 plus #130. The reheat state is OFF.	ON	OFF	OFF
Compressor is running and the RH TEMP is less than set point #129. The reheat state is STARTING. It will remain in this state until the time is greater than set point #131, it will then move to the ON state.	ON	ON	ON
The reheat state is ON. The reheat will remain in this state until the reheat temperature is greater than set point #129 plus #130. When the temperature is greater the state will be changed to BLEED.	OFF	ON	ON
The reheat state is BLEED. . It will remain in this state until the time is greater than set point #132, it will then move to the OFF state.	ON	OFF	ON

16.37. Outside Air Economizer/Fluid Cooler with Analog Output Control

Energy conservation is an important part of any Heating, Ventilating, and Air Conditioning (HVAC) system design and operation today. The purpose of an economizer/fluid cooler is to take advantage of free cooling in addition to the use of mechanical cooling. To take full advantage of all available free cooling a number of options can be specified in the MCS Config program.

16.37.1. Set up

Compressor Information

Compressor Type Scroll Comp	Unit Type <input checked="" type="radio"/> Cooling Only <input type="radio"/> HeatPump <input type="radio"/> Electric Heat	CW Pump/Fan Defrost <input checked="" type="radio"/> On During Def. <input type="radio"/> Off During Def.
Economizer AO 3WAY VLV	Separate Economizer Fans? <input checked="" type="radio"/> Yes <input type="radio"/> No	Heat Mode Indicator Not Used
Starting Economizer Fan EcFanRD	# of Econ Fans 1	Defrost Type None
Starting Economizer Fault EcFanFlt	# of Econ Faults 1	Common Reversing Valve Not Used
		Pre-Pump Out <input checked="" type="radio"/> Yes <input type="radio"/> No

The analog valve that will be modulated is selected in the **Economizer AO** cell in the **Compressor Information** section. In this example the name is 3WAY VLV.

If the economizer/fluid cooler has separate fans (not associated with condensers) answer **Yes** in the **Economizer Fans?** cell else No. If Yes, then four additional cells will appear: **Starting Economizer**

Fan, select the first fan relay output. **# of Econ Fans**, specify the number of fan points. **Starting Economizer Fault**, select the first fan fault, this is a sensor input. **# of Econ Faults**, specify the number of faults.

In the above example there is one fan and one fault associated with the economizer/fluid cooler. If there is more than one fan they must be consecutive relay outputs. The same is true of the condenser faults.

Condenser Information

Condenser Type

RO Step Individual ▼

With Economizer?

Yes No

Control Condenser On:

Disc PSI Other SI

The condenser fans can also be used to assist in the free cooling function when the system is not using mechanical cooling. All types of condensers can be used. The above example has individual fans per circuit. When ever a circuit is running the control of its condenser fans will be based solely on the discharge pressure of that circuit; the condenser fans of circuits that are not running will be controlled by the economizer function. If the type of condenser is common; if any circuit is on all of the fans will be controlled by the highest discharge pressure and not by the economizer function.

The following set points must be set up:

107	EcoDelayMech	Value in seconds is the delay after the economizer is fully loaded, valve opened to its maximum and all associated fans are on, before the mechanical cooling is enabled. . If this set point is inactive then the value of set point #125 will be used for this delay.
115	EcoVFDfanDely	If the fluid cooler has a condenser VFD fan associated with it, this set point will be the time delay in seconds between adjustments to the VFD. If this set point is inactive then the value of set point #124 will be used for this delay timer.
119	EcoOffsetON	Temperature off set used to determine if the economizer function could be started. The ambient temperature must be less than target temperature minus the value of this set point. For example if the target is 45.0F and this value is 10.0F then the ambient temperature must be less than 35.0F to enable the economizer to begin.
120	Eco Stg Dely	Once the economizer valve has been opened to its maximum and all fans associated only with the economizer if any have been turned on; the economizer function will wait this time, expressed in seconds, before the first condenser fan is turned on or if a VFD it will be set to its minimum position. The minimum setting of the VFD is the value of set point #54.
121	Eco MIN VLV%	Economizer minimum Analog Output valve %. When the economizer function begins the valve is opened to this value. When closing the valve this will be the minimum setting. This set point must be active to indicate that the Economizer AO option is active.
122	Eco MAX VLV%	Economizer maximum Analog Output valve %. This is the maximum that the valve can be opened.

123	Eco MAX ADJ	Economizer maximum adjustment to the Analog Output valve % with each calculation. Example: $\{\text{abs}(\text{Target} - \text{current}) * \text{Multiplier}\} / \text{Divisor}$
124	EcoVlvAdjDly	Economizer delay between output valve adjustments.
125	Eco StageDly	Time delay once the valve has been opened to its maximum and turning on the associated condenser fans.
126	Eco MULTI	Economizer multiplier to scale adjustment to Analog Output valve %. The difference between the control temperature and its target will be multiplied by this value.
127	Eco DIVIDE	Economizer divisor to scale adjustment Analog Output valve %. The difference between the control temperature and its target will be divided by this value.

16.37.2. Sequence Of Operation

The Economizer logic will be enable when ever the ambient temperature meets the requirement as stated in set point #119. The ambient temperature must be less than target temperature minus the value of this set point. For example if the target is 45.0F and this value is 10.0F then the ambient temperature must be less than 35.0F to enable the economizer function to begin.

If mechanical cooling has NOT been enabled, zero steps are wanted on and zero steps are on, when the economizer starts the Unit State will be ECONOMIZER ONLY. When in this state mechanical cooling will NOT be started until the economizer function has reached its maximum capacity. That is the valve is at maximum opening and all available fans have been turned on and the control temperature is still not with in its target zone. At this point mechanical cooling may be used.

When the economizer logic starts, the valve will be staged from the value of set point #121, minimum opening, to the value of set point #122, maximum valve opening. The system will wait the time contained in set point #124 before making any adjustment to the valve opening. The system will modulate the Analog Output valve % to maintain the entering temperature sensor reading within the temperature control zone.

If control temperature is above the control target, set points #1, and the control temperature rate of change, slope, is greater than the value of set point #27, MAX ROC-, the Analog Output valve % will be adjusted as follows:

This indicates that the control temperature is high and it is not moving toward the target fast enough; therefore, the valve opening must be increased if possible.

The amount of adjustment will be the difference between the control temperature target (set points #1) and the actual control temperature. This difference will then be scaled by the multiplier in set point #126 and divided by set point #127. If the absolute adjustment is greater than the value of set point #123 it will be limited to this value.

The economizer valve opening will be increase by this value.

If control temperature is below the control zone, set points #1 - set points #3, and the control temperature rate of change, slope, is less than the value of set point #28, MAX ROC+, the Analog Output valve % will be adjusted as follows:

This indicates that the control temperature is low and it is not moving toward the target fast enough; therefore, the valve opening must be decreased if possible.

The amount of adjustment will be the difference between the control temperature target (set points #1) and the actual control temperature. This difference will then be scaled by the multiplier in set

point #126 and divided by set point #127. If the absolute adjustment is greater than the value of set point #123 it will be limited to this value.

The economizer valve opening will be decrease by this value.

If control temperature is above the bottom of control zone, set points #1 - set points #3, but less than the control target, set point #1 no change to the economizer valve opening will be made.

NOTE: The control rate of change is always checked before an adjustment to the valve is made. The purpose to not move the valve opening if the temperature is moving toward the target fast enough.

Once the valve has reached its maximum opening (set point #122), the system will wait the time specified in set point #125 before checking if there are any fans associated with the economizer function. If there are the system will turn on and off the fans in an attempt to maintain the control temperature with in the control zone. If there is a VFD, this will be modulated in the same matter. The delay between VFD adjustments will be the value in set point #115 if active else set point #124 will be used. Once all of the fans directly associated with the economizer function has been turn on, the system will when check to determine if any condenser fans can also be used. If yes these fans will then be turned on or off to maintain the control temperature.

Once all the fans and/or VFD (if any) have been turned on and the control temperature is still greater than the control zone for the time specified in set point 107 if it is active else the time in set point125 will be used, mechanical cooling will be enabled.

If during the economizer function the ambient temperature becomes too high, the economizer function will be terminated, its valve will be set to zero percent opening, and mechanical cooling will be enabled.

If during mechanical cooling the ambient temperature drops and is now acceptable, the economizer function will begin. Note, the Unit State will NOT change, the economizer valve will be modulated as described above, fans directly associated with the economizer will be used, and NO fans associated with the condensers will used.

16.37.3. Economizer Function Is To Supply Outside Air

If the purpose of the economizer is to provide outside air then there will be no fans associated with the economizer and no condenser fans will be used. In this setup, the economizer valve opening will never be less than the value of set point #121, Eco MIN VLV%. This is required to supply the minimum of outside air.

16.37.4. Mechanical Cooling Enabled

Once mechanical cooling has been enabled only the economizer will control the individual circuit condenser fans whose compressors have not been started. The discharge pressure will control all others.

The percentage of the economizer valve opening will not be decreased. It will remain at its maximum setting. All stages of mechanical cooling must be off before the economizer valve will begin to close.

16.37.5. Termination of the Economizer Function

If at any time the ambient temperature is greater than the target temperature, set point #1, minus the value of set point #119; the economizer function will be terminated and its valve opening will be set to zero and all fans that it is controlling will be turned off.

If at any time the control temperature is less than the target temperature, set point #1, minus the 3 times value of set point #3; the economizer function will be terminated and its valve opening will be set to zero and all fans that it is controlling will be turned off.

16.37.6. Example: Fluid Cooler with VFD condenser fan

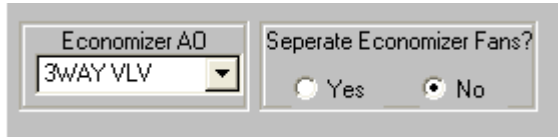

The economizer AO has been selected and there are no separate economizer fans.

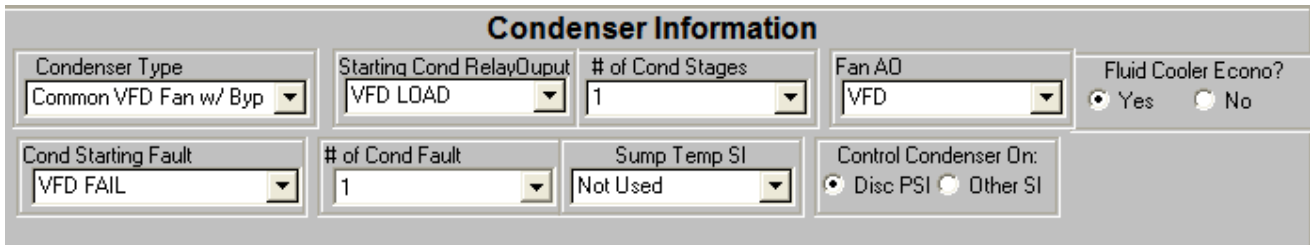

The condenser type is common with VFD control and the fluid cooler economizer option has been selected. The VFD of the condenser fan will be controlled by the economizer function unless any circuit is running. If a circuit is running the VFD control will be based upon the highest discharge pressure and not the economizer function.

Assume the following setup:

Set point #	Name	Value
1	SPPY TRGT	44.0F
2	CTRL ZONE+	2.0F
3	CTRL ZONE-	1.0F
27	MAX ROC-	-.6F
28	MAX ROC+	.6F
54	CND MIN OPEN	20.0%
55	CND MAX OPEN	100.0%
107	ECON-MECHdly	240s
115	EconVFDdelay	45s
119	EcoOffsetON	10.0F
120	EconDelyFans	60s
121	EcoVlvMinVlv	0.0%
122	EcoVlvMaxVlv	100.0%
123	EcoVlvMaxAdj	5.0%
124	EcoVlvDelay	30s

125	EcoVlvMaxDly	120s
126	EcoVlv Mul	3
127	EcoVlv Div	2

Analog output	Name
AO M-1	3WAY VLV
AO M-2	VFD LOAD

Conditions when the run/stop was set to RUN

Ambient temperature	30.0F
Control temperature	48.5F

The ambient temperature is less than 44.0 (set point #1) – 10.0 (set point #119) and no mechanical cooling steps are on; therefore, the Unit state will be ECONOMIZER ONLY and the economizer function will be enabled.

The 3WAY VLV, AO M-1, will be opened to its minimum valve of 0% (set point #121) and it will be modulated based upon the control temperature and the target (set point #1). The first adjustment will be $48.5 - 44.0 = 4.5$. This value will be adjusted by multiplier of 3 (set point #126) and divided by 2 (set point #127) to give an adjusted value of 6.7. This value is blocked; maximum allowed adjustment, by set point #123 to allow an adjustment of 5.0%. The economizer valve opening will be increased by this amount if the temperature control rate of change is greater than the value of set point #27.

The economizer function will wait 30 seconds (set point #124) before determining the next adjustment. If the control temperature is now 47.3F; the following adjustment will be calculated.
 $47.3 - 44.0 = 3.3 \times 3 / 2 = 4.9$. Since this is less than 5.0 the valve will be open an additional 4.9% if the temperature control rate of change is greater than the value of set point #27.

Each adjustment will be made after a delay of 30 seconds. If the control temperature is below the control target, set point #1, and above the bottom the control zone (43.0F to 44.0F) there will be no change to valve opening.

If the control temperature drops below the control zone the valve opening will be reduced. For example if the control temperature is 42.6F then the following calculation will be made:
 $42.6 - 44.0 = 1.4 \times 3 / 2 = 2.1$. Since this is less than 5.0 the valve opening will be reduced an additional 2.1%.

When the valve reaches its maximum opening of 100.0% (set point #122) the economizer function will use other fans if they are available. In this example there are no fans that are associated only with economizer but the VFD fan can now be used. At time delay of 120 seconds (set point #125) be for the VFD will be modulated. Following this initial delay the VFD will be opened to its minimum opening, set point #54 of 20%.

At this point the unit state is ECONOMIZER ONLY, economizer valve is at 100% and VFD will be modulated between its minimum, set point #54 and it maximum, set point #55. The delay between these adjustments will be 45 seconds, value of set point #115.

Once the VFD opening is equal to its maximum, set point #55; there will be a delay of 240 seconds, value of set point #107. At this time the unit state will be changed and mechanical cooling will be enabled.

16.37.7. Example: Fluid Cooler with condenser circuit fans

Compressor Information

Compressor Type

Unit Type
 Cooling Only
 HeatPump
 Electric Heat

CW Pump/Fan Defrost
 On During Def.
 Off During Def.

Control of Oil Pump
 Always ON
 Cycle/Needed
 Only Lube State

Heat Mode Indicator

Defrost Type

Economizer AO

Seperate Economizer Fans?
 Yes
 No

Common Reversing Valve

Pre-Pump Out
 Yes
 No

The economizer AO has been selected and there are no separate economizer fans.

Condenser Information

Condenser Type

Fluid Cooler Econo?
 Yes
 No

Control Condenser On:
 Disc PSI
 Other SI

The condenser type is RO Step Individual and the fluid cooler economizer option has been selected. The individual circuit condenser fans will be controlled by the economizer function unless a circuit is running. If a circuit is running the condenser fans associated with that circuit will be controlled based upon the discharge pressure of the compressor that is running and not the economizer function. The economizer function will continue to control condenser fans on circuits that are not running.

Assume the following setup:

Set point #	Name	Value
1	SPPY TRGT	44.0F
2	CTRL ZONE+	2.0F
3	CTRL ZONE-	1.0F
27	MAX ROC-	-.6F
28	MAX ROC+	.6F
107	ECON-MECHdly	240s
115	EconVFDdelay	45s
119	EcoOffsetON	10.0F
120	EconDelyFans	60s
121	EcoVlvMinVlv	10.0%
122	EcoVlvMaxVlv	100.0%
123	EcoVlvMaxAdj	10.0%
124	EcoVlvDelay	30s
125	EcoVlvMaxDly	120s
126	EcoVlv Mul	2
127	EcoVlv Div	1

Analog output	Name
AO M-1	ECONOMZR

Conditions when the run/stop was set to RUN

Ambient temperature	30.0F
Control temperature	49.7

The ambient temperature is less than 44.0 (set point #1) – 10.0 (set point #119) and no mechanical cooling steps are on; therefore, the Unit state will be ECONOMIZER ONLY and the economizer function will be enabled.

The ECONOMZR, AO M-1, will be opened to its minimum valve of 10% (set point #121) and it will be modulated based upon the control temperature and the target (set point #1). The first adjustment will be $49.7 - 44.0 = 5.7$. This value will be adjusted by multiplier of 2 (set point #126) and divided by 1 (set point #127) to give an adjusted value of 11.4. This value is blocked; maximum allowed adjustment, by set point #123 to allow an adjustment of 10.0%. The economizer valve opening will be increased by this amount if the temperature control rate of change is greater than the value of set point #27. NOTE: With set point #126 equal to 2 and #127 equal to 1; the valve will be adjusted by 2% for every degree difference from the target.

The economizer function will wait 30 seconds (set point #124) before determining the next adjustment. If the control temperature is now 47.3F. The following adjustment will be calculated.
 $47.3 - 44.0 = 3.3 \times 2 / 1 = 6.6$. Since this is less than 10.0 the valve will be open an additional 6.6% if the temperature control rate of change is greater than the value of set point #27.

Each adjustment will be made after a delay of 30 seconds. If the control temperature is below the control target, set point #1, and above the bottom the control zone (43.0F to 44.0F) there will be no change to valve opening.

If the control temperature drops below the control zone the valve opening will be reduced. For example if the control temperature is 42.6F then the following calculation will be made:
 $42.6 - 44.0 = 1.4 \times 2 / 1 = 2.8$. Since this is less than 10.0 the valve opening will be reduced an additional 2.8%.

When the valve reaches its maximum opening of 100.0% (set point #122) the economizer function will use other fans if they are available. In this example there are no fans that are associated only with economizer but the condenser fan can now be used. At time delay of 120 seconds (set point #125) be for the first condenser fan will be turned on, this will be first fan of the first circuit unless it is not available.

At this point the unit state is ECONOMIZER ONLY, economizer valve is at 100% and the circuit fans will be used to aid in the economizer cooling. The delay between turning on the condenser fans will be 30 seconds, value of set point #124. If all condenser fans are available, not have been placed in manual off, the pattern of turning on the fans will be the first fan on circuit 1, after the delay the first fan of circuit 2, after the delay the second fan on circuit 1. This will continue until all of the available condenser fans have been turned on. At this point the economizer has used all of its available resources to maintain the control temperature with in its control zone.

Once all of the condenser fans have been turned on; there will be a delay of 240 seconds, value of set point #107. At this time the unit state will be changed and mechanical cooling will be enabled. When a circuit is running, its associated condenser fans will be controlled by the discharge pressure of the running compressors.

16.38. Extra Liquid Line Solenoid Control

Both two and three liquid line solenoid are supported for extra control. To specify, select the Circuit Base Button:

Information that relates		
2nd LLS	3rd LLS	3rd LLS Control
Yes ...	Yes ...	Slide % ...

The third solenoid can be controlled either on the slide wanted percentage or as the last step is on for that circuit. The following set points will be used:

98	LLS#2 ON	<p>The value, safety time and delay between trips fields can be used. This set point is used to control a 2nd liquid line solenoid. Value: When the chiller capacity wanted is greater then this value for number of seconds contained in the Safety Time Field the 2nd liquid line solenoid will open. When the circuit capacity is below the value in Delay Between Trips Field the value will be turned off. Safety Time Field: This field contains a forced delay before the solenoid will be turned on. If it is zero then there will be no delay. Delay Between Trips Field: This field contains the cut off offset for turning this solenoid off. If it is zero then an offset of 20 will be used.</p>
99	LLS#3 ON	<p>The value, safety time and delay between trips fields can be used. This set point is used to control a 3rd liquid line solenoid. Value: When the chiller capacity wanted is greater then this value for number of seconds contained in the Safety Time Field the 3rd liquid line solenoid will open. When the circuit capacity is below the value in Delay Between Trips Field the value will be turned off. Safety Time Field: This field contains a forced delay before the solenoid will be turned on. If it is zero then there will be no delay. Delay Between Trips Field: This field contains the cut off offset for turning this solenoid off. If it is zero then an offset of 20 will be used.</p>

Liquid line solenoids 2 and 3 will be turned on and off as indicated in their set points.

16.39. Special Pattern for Scroll Compressors

Special patterns have been developed for Trane Scroll 3-D compressors, HVAC 7.00 software and later are required for this function. These patterns are for either a 3 or 4 scroll unit. They are specified by selecting either the Trane Trio for the three-compressor package or Trane Quad for the four-compressor package in the Compressor Type selection under the MAG CHL button. The sequencing will provide proper oil control for the Trane compressors.

The compressors set will be treated as one circuit. There will be one common suction pressure, suction temperature, and discharge pressure and discharge temperature sensors. Each compressor will have an amp sensor and they must be consecutive inputs.

New chiller states have been allocated for these patterns: "SCROLL STEP 1" through "SCROLL STEP 4".

16.39.1. The following is a sample of the four-compressor setup:

Select compressor type:

Compressor Information

Compressor Type:

Unit Type: Cooling Only HeatPump Electric Heat

CW Pump/Fan Defrost: On During Def. Off During Def.

Pre-Pump Out: Yes No

Heat Mode Indicator:

Defrost Type:

of Circuits and # of steps:

Magnum Chiller V8 Information Screen

General Information

of Circuits: # of Steps:

Run/Stop Switch:

Phase Loss:

Ambient Temperature:

Ambient Humidity:

Turbo Ice Machine: Yes No

Network Run/Stop Sw:

Emergency Stop Switch:

Target (SP #1) Reset:

Alarm Output:

Enthalpy Sensor:

Control Temperature On: Leaving Tmp Entering Tmp

Control Method Control Zone: Control Zone Cut In/Out

1st MOD Motor Limit RO:

Warning Relay:

Demand Limit:

Target Reset: Ice Mode: DI On/Off Normal: AI:0-5V

Control Relay:

Lost BMS Communication: Run Stop No Change

Set up circuit:

MAGNUM Circuit Base Screen

Information that relates to compressors on the circuit

Circuit # (reset button)	# of Comp ROs	Starting Compressor RO	Part Winding	Start Unload Bypass	Fast Unloader	Type of LLS	2nd LLS	3rd LLS	3rd LLS Control	Unloading Stages	Loader Type	HGB	HG Reheat	Liquid Injection	Oil Equalize	Mod Motor Control	Low Disc SuperHeat
1	5	COMP A	No	No	No	EXV&LLS	No	No	Last Step	3	Loader	None	No	No	No	No	No

Set up relay outputs:

Relay Output Information Screen (Magnum)

# w/ HELP Button	Name	Slide Multiple	Slide Division	Slide Offset	Design Suction PSI	Design Disc PSI	Nominal Tonnage(of Step)	EXV Start (when lead)	EXV off Adj % Diff	Type
M-1	CND FAN	---	---	---	---	---	---	---	---	Standard
M-2	SYS PUMP	---	---	---	---	---	---	---	---	Standard
M-3	COMP A	---	---	---	---	---	15	12	---	Step w\ EXV
M-4	EEVENABL	---	---	---	---	---	---	---	---	Standard
M-5	COMP B	---	---	---	---	---	15	12	---	Step w\ EXV
M-6	COMP C	---	---	---	---	---	15	12	---	Step w\ EXV
M-7	COMP D	---	---	---	---	---	15	12	---	Step w\ EXV
M-8	SpareM-8	---	---	---	---	---	---	---	---	Standard
M-9	SpareM-9	---	---	---	---	---	---	---	---	Standard
M10	ALARM	---	---	---	---	---	---	---	---	Standard

16.39.2. Pattern of the four-compressor setup:

	COMP A	COMP B	COMP C	COMP D
SCROLL STEP 1:	ON	OFF	OFF	OFF
SCROLL STEP 2:	OFF	OFF	ON	ON
SCROLL STEP 3:	OF	ON	ON	ON
SCROLL STEP 4:	ON	ON	ON	ON

16.39.3. The three-compressor type will be setup in as follows:

Select the compressor:

Compressor Information

Compressor Type Trane Trio	Unit Type <input checked="" type="radio"/> Cooling Only <input type="radio"/> HeatPump <input type="radio"/> Electric Heat	CW Pump/Fan Defrost <input checked="" type="radio"/> On During Def. <input type="radio"/> Off During Def.	Pre-Pump Out <input type="radio"/> Yes <input checked="" type="radio"/> No
-------------------------------	---	--	---

of Circuits and # of steps:

General Information

# of Circuits 1	# of Steps 3	Run/Stop Switch RUN/STOP	Phase Loss PHASLOSS	Ambient Temperature AMB TEMP	Ambient Humidity Not Used	Turbo Ice Machine <input type="radio"/> Yes <input checked="" type="radio"/> No
--------------------	-----------------	-----------------------------	------------------------	---------------------------------	------------------------------	--

Set up circuit:

MAGNUM Circuit Base Screen

Information that relates to compressors on the circuit

Circuit # (reset button)	# of Comp ROs	Starting Compressor RO	Part Winding	Start Unload Bypass	Fast Unloader	Type of LLS	2nd LLS	3rd LLS	3rd LLS Control	Unloading Stages	Loader Type	HGB	HG Reheat	Liquid Injection	Oil Equalize	Mod Motor Control	Low Disc SuperHeat
1	4	COMP A	No	No	No	EXV&LLS	No	No	Last Step	2	Loader	None	No	No	No	No	No

Set up relay outputs:

Relay Output Information Screen (Magnum)

# w/ HELP Button	Name	Slide Multiple	Slide Division	Slide Offset	Design Suction PSI	Design Disc PSI	Nominal Tonnage(of Step)	EXV Start (when lead)	EXV off Adj % Diff	Type
M-1	CND FAN	---	---	---	---	---	---	---	---	Standard
M-2	SYS PUMP	---	---	---	---	---	---	---	---	Standard
M-3	COMP A	---	---	---	---	---	15	12	---	Step w\ EXV
M-4	EEVENABL	---	---	---	---	---	---	---	---	Standard
M-5	COMP B	---	---	---	---	---	15	12	---	Step w\ EXV
M-6	COMP C	---	---	---	---	---	15	12	---	Step w\ EXV
M-7	SpareM-7	---	---	---	---	---	15	12	---	Step w\ EXV
M-8	SpareM-8	---	---	---	---	---	---	---	---	Standard
M-9	SpareM-9	---	---	---	---	---	---	---	---	Standard
M10	ALARM	---	---	---	---	---	---	---	---	Standard

16.39.4. Pattern of the three-compressor setup:

	COMP A	COMP B	COMP C
SCROLL STEP 1:	OFF	OFF	ON
SCROLL STEP 2:	ON	ON	OFF
SCROLL STEP 3:	ON	ON	ON

16.39.5. Safeties are the same for both compressor types

The standard unloading and holding logic has been incorporated with their circuit state names. When a step is unloaded it will go to the previous step pattern. For example if the circuit is in SCROLL STEP 3 and unloading is required the relay output for SCROLL STEP 2 will be used. The state name will reflect why the circuit has unloaded.

The unloading and holding can result from high discharge and low suction pressure and high discharge temperature.

Low and high amp drawn will be check for all compressors that are on. The standard amp safety checks will be made and if one occurs the circuit will be off on a safety or a lock out if the same safety reoccurs.

Note, the standard set points are used for all safety checks and the unload and holding functions.

17. MAGNUM Alarms and Safeties

17.1. Introduction

There are three types of alarms that are generated by the MAGNUM control logic:

- Information only alarms,
- MAGNUM system alarms and
- Chiller set point safety alarms.

All of the alarms have the same format. The alarm is identified and it is date time stamped. Alarms can be viewed from the MAGNUM by pressing the ALARM STATUS (4) key or from the MCS-Connect program.

17.2. Information only alarms

17.2.1. System generated alarms

The following alarms are generated to provide information; they will not cause a change in the control algorithm such as a lock out condition or a relay output being forced off.

- POWER FAILED
- POWER RETURNED
- COMPUTER RESET
- LCD FAILURE
- HW DATE INVALID
- HW TIME INVALID
- SW DATE INVALID
- SW TIME INVALID
- RAM INTEGRITY
- WATCHDOG RESET
- LOST A/D CONVTR
- LOST DISPLAY
- CF INIT ERROR

17.2.2. Alarms as a result of individual action

The following alarms indicate that an individual took action:

- ALARMS CLEARED
- STPT CHANGED
- RO MANUAL
- AO MANUAL
- SI MANUAL
- POINT INFO CLEAR
- CLOCK SET
- CFG DOWNLOADED
- NETWORK ADDR CHG
- RS485 CHANGED
- CF CARD REMOVED
- CF CARD INSERTED

17.2.3. Alarms generated by the control algorithm

The following alarms indicate that the control algorithm took action:

- ROTATED LEAD
- DAYLIGHT SAVINGS

17.3. MAGNUM system alarms

17.3.1. Alarms are generated by the MAGNUM control algorithm:

17.3.1.1. Configuration problem alarms

These alarms indicate a problem with the configuration file that has been loaded into the system. The system is not operational, a configuration must be transmitted to the unit form MCS-Connect or the config chip must be replaced with a valid one.

- INVALID CONFIG. (Check if sums are incorrect)
- INVALID CFG VER (version number of the configurator is invalid)
- INVALID CFG TYPE (the type does not agree with software, chiller software with a home unit configuration)

17.3.1.2. MCS local network problem alarms

These alarms indicate problems with the MCS local network, the system can be accessed but the system is in a lock out state, LOST I/O.

- MCS-I/O 1 LOST
- MCS-I/O 2 LOST
- MCS-I/O 3 LOST
- MCS-STAT OFFLINE
- LOST IO SHUTDOWN

17.3.1.3. Key sensors problem alarms

This alarm indicate a problem with a key sensor, it is either shorted or open. The alarm will contain ALARM followed by the 8-character name of the sensor.

The following sensors related to the entire system are tested:

- Leaving liquid, if failed: lock out the chiller system
- Returning liquid, if failed: alarm only no lock out
- Ambient temperature, if failed: alarm only no lock out

The following circuit sensors are tested. If they fail that circuit only is locked out.

- Suction pressure and temperature
- Discharge pressure and temperature
- Oil pressure and temperature
- Motor temperature (if it is an analog input device)

17.3.1.4. EMERGENCY STOP alarm

This alarm indicates that the emergency stop switch has been turned on. The system can be accessed but the entire system is in a lock out state.

- EMERGENCY STOP

17.4. Set Point safety alarms

17.4.1. Introduction

The MAGNUM chiller algorithm incorporates a number of safety checks to ensure that the various components that make up the chiller package are not damaged. These types of safeties are based upon set points. When a safety trips for the first time, the compressor will be set to "SAFETY TRIPPED" state. The compressor will remain in "SAFETY TRIPPED" state for ten minutes and then move to the "CMP IS OFF" state where the compressor will be allowed to run if required. If the same safety trips occurs again within two hours of the first trip, the compressor will be set to "CMP LOCKED OUT" state, which requires a manual reset to restart the compressor. In this matter the MAGNUM attempts to take corrective action to protect the compressors but avoid nuisance trips.

The time in the safety state and the time between safeties are specified in the individual set points. This enables the times to be unique for each lock out set point.

17.4.2. Sensor inputs used in conjunction with MAGNUM set point safeties:

Suction Pressure

Pressure transducer to read the suction pressure. (Optional digital input)

Discharge Pressure

Pressure transducer to read the discharge pressure. (Optional digital input)

Oil Pressure

Pressure to read the oil pressure (optional digital input)

Oil Differential Pressure

Calculated value of the oil pressure as follows:

- Fixed step compressors, oil psi minus suction psi
- Screws with oil pump, Oil psi minus discharge psi
- Screws without oil pump, discharge psi minus suction psi

Oil Temperature

Either a temperature sensor or a digital input that indicates when a high temperature condition exists.

Discharge Temperature

Either a temperature sensor or a digital input that indicates when a high temperature condition exists.

Motor Temperature

Either a temperature sensor or a digital input that indicates when a high temperature condition exists.

Motor Amps

Sensor input that measures AMP draw of the compressor. (Optional digital input)

Motor Fault

A digital input that indicates when a motor fault condition exists or an analog sensor that will read resistance value. If an analog sensor, a set point is required that contains the resistance value that the sensor will indicate on safety trip. This is a general fault indicator, that may have been caused by high temperature, amp draw etc.

Liquid Temperature

Temperature sensor that can be used to detect a freeze condition

Compress Proof

A digital input that when on indicates that a compressor is running.

Flow Switch

A digital input that indicates that flow through the chiller barrel exists. There can be one switch per chiller or one for each circuit.

17.4.3. Set point safeties

For a safety to be interrogated, both the associated sensor input and the lockout set point must be active. If a safety trips, the alarm name will consist of the set point name plus additional identification such as point number or circuit number if applicable.

The system exercises "smart" safety testing in the following manner:

If a safety applies to a circuit and it is an active lockout type of a set point, the first time this safety trips an alarm will be generated and the circuit will be shut down and placed in a safety state. The system will attempt to reactivate this circuit after waiting the length of time specified in this set point, safety down time. If successful the system will continue to run. If the same safety trips the time specified in the lockout delay time, the circuit will be locked off and a manual intervention is

required. If the lockout delay time is set to zero, the system will generate a lockout condition the first time that the safety occurs.

The time in the safety state and the time between safeties are specified in the individual set points. This enables the times to be unique for each lock out set point.

MOST SAFETIES ARE CHECKED ONLY IF THE COMPRESSOR IS RUNNING, IF THE SAFETY IS ALWAYS CHECKED IT WILL BE SO NOTED.

The following are a list of safeties that are incorporated in the standard chiller algorithm control. These safeties are checked every second. Note, for a multiple circuit system, each circuit is tested individually. If a safety condition exists, action will be taken with that circuit only, other circuits will continue to function.

Freeze Protection (SAFETY IS ALWAYS CHECKED)

If the leaving liquid temperature drops below the set point value the system, and all circuits, will enter a lockout state and a freeze notification alarm will be generated. You have the option of one freeze protect for the package or individual freeze protections by circuit. This is selected in the **MCS-Config** program.

No Flow Protection

If the flow switch is for the chiller system, then the entire system will be shut down with the LOCK OUT state if set point 105, PUMP FAILURE, is an active lockout type of set point. If the set point is inactive, the system will determine if there is a second pump, if so it will be started. Else, the system will be shut down and automatically restarted when the flow switch is on, indicating that there is flow. If the flow switch is for the individual circuit, then that circuit will be locked out.

Phase Loss Protection

Phase loss, as indicated by the phase loss monitor, will result in the system and all circuits being locked off and a phase loss notification alarm will be generated. No set point is required.

Emergency Stop

Emergency stop, as indicated by the emergency stop switch, will result in the system and all circuits being locked off and an emergency stop notification alarm will be generated. No set point is required.

Low Differential Oil Pressure

This safety is designed to meet the compressor manufacturer requirements on oil pressure. For the first 5 (60 seconds if setup as Hitachi screw compressors) seconds following a compressor start this safety is NOT checked. For the next 30 seconds, if the oil differential pressure drops below ½ of the value of the set point or the digital input turns ON and it remains there for the time specified in the safety time of that set point, the compressor will be locked out and a low oil alarm generated. After this time period, if the oil differential pressure drops below the value of the set point and it remains there for the time specified in the safety time, the compressor will be locked out (as described in section 'Chiller set point safety alarms.') and a low oil alarm generated. This enables the set point value and the safety time to be much tighter. This safety is interrogated when the compressor is on and not in a pump down state.

Low Suction Pressure

If the suction pressure drops below the value of the set point or the digital input turns ON and it remains there for the time specified in the safety time, the compressor will be locked out and a low suction alarm generated. For the first 5 minutes after the compressor has started the safety time is extend by 2 minutes, this enables the set point safety time to be set much tighter for normal operation. This safety is bypassed when the compressor is in the "CMP PUMP DOWN" state. This safety can also be used as a freeze protection based upon the suction PSI. When this safety occurs, all circuits in the same suction group will react the same.

Unsafe Suction Pressure

This safety is similar to the low suction pressure safety except this set point can be set up with a lower value and a very short safety time. If the suction pressure drops below the value of the set point or the digital input turns ON and it remains there for the time specified in the safety time of that set point, the compressor will be locked out and a low suction alarm generated. This safety will always cause a lock

out on the first trip requiring a manual reset to restart the compressor. For the first 5 minutes after the compressor has started the safety time is extend by twice the normal time delay, this enables the set point safety time to be set much tighter for normal operation. . This safety is bypassed when the compressor is in the “CMP PUMP DOWN” state. When this safety occurs, all circuits in the same suction group will react the same.

Low Discharge Pressure

If the discharge pressure drops below the value of the set point and it remains there for the time specified in the safety time of that set point, the compressor will be locked out and a low discharge alarm generated.

High Discharge Pressure (SAFETY IS ALWAYS CHECKED)

If the discharge pressure raised above the value of the set point or the digital input turns ON and it remains there for the time specified in the safety time of that set point, the compressor will be locked out and a high discharge alarm generated.

High Discharge Temperature (SAFETY IS ALWAYS CHECKED)

If the discharge temperature analog input rises above the value of the set point or the digital input turns ON and it remains there for the time specified in the safety time, the compressor will be locked out and a high temperature alarm generated.

HI Motor Temp or Motor Fault (SAFETY IS ALWAYS CHECKED)

If the high motor temperature input rises above the value of the set point or the digital input turns ON and it remains there for the time specified in the safety time, the compressor will be locked out and a high motor temperature or motor fault alarm generated.

Hi Oil Temp

If the oil temperature rises above the value of the set point or the digital input turns ON and it remains there for the time specified in the safety time of that set point, the compressor will be locked out and a high oil temperature alarm generated.

Hi Motor Amp

If the ampere analog input rises above the value of the set point or the digital input turns ON and it remains there for the time specified in the safety time of that set point, the compressor will be locked out and a high motor amp alarm generated. This safety is bypassed for the first 3 seconds after a compressor has started.

Low Motor Amp

If the ampere analog input drops below the value of the set point and it remains there for the time specified in the safety time of that set point, the compressor will be locked out and a low motor amp alarm generated. This alarm can be used to indicate low refrigerant. This safety is bypassed for the first 3 seconds after a compressor has started.

No Compress Proof

If a compressor is called to be on and the compressor proof input is off (this is a digital input), a NO COMP PROOF alarm will be generated.

High Oil Seal Temperature (Screw Compressors only)

If the oil seal temperature analog input rises above the value of the set point and it remains there for the time specified in the safety time of that set point, the compressor will be locked out and a high oil seal alarm generated. This safety is bypassed for the first 4 minutes after a compressor has started and when the compressor is in the “CMP PUMP DOWN” state.

Dirty Oil Filter (Fixed Step Compressors only)

If the difference between the discharge pressures minus the oil pressure is above the value of the set point and it remains there for the time specified in the safety time of that set point a dirty oil filter alarm

will generate. If the difference raises 20.0 above the set point then the compressor is locked out on the first trip requiring a manual reset to restart the compressor.

Low Discharge Superheat

If the discharge superheat is below the value in set point and remains there for the time specified in the safety time of that set point, the compressor will be locked out and a low discharge superheat alarm will be generated. This safety is bypassed for the first 4 minutes after a compressor has started.

18. Magnum Control States Quick Reference

Control States tell the user the system's status; this information is critical. From the Magnum keypad / display, press the menu key and select STATUS> The control status is the second line. MCS Control States Quick Reference – CHL R & I 8.00 Software

Control States tell the user the system's status; this information is critical!

CAPACITY CONTROL STATES

CIRCUIT CONTROL STATES

STATE	DESCRIPTION
UNIT IN POWER	System Reset or Power Returned (delay of 60 seconds or set point value)
UNIT IS OFF	System ready to run but no cooling capacity required
RUN/STOP SW OFF	Disabled: run/stop switch is off.
SCHEDULED OFF	Disabled: operating schedule is false.
OFF NO EVAP FLOW	Disabled: no evaporator flow.
AMBIENT OFF	Disabled: either high or low ambient temperature.
UNIT IN LOCKOUT	Chiller locked out, all points except alarm point are OFF
NO RUN- IO LOST	Lost communication Chiller locked out
UNIT IS HOLDING	No change in capacity
UNIT UNLOADING	Reduce capacity
UNIT LOADING	Increase capacity
UNIT IS UNLOADED	Unit is unloaded, No cooling capacity is being provided.
UNIT IS LOADED	Unit is loaded, maximum cooling capacity is being provided.

STATE	DESCRIPTION
CMP OFF/READY	Circuit ready but not required or has not been in this state for 60 seconds
OIL PMP LUBING	Screw wanted ON, waiting for good oil pressure and temp and slide fully unloaded
FAST UNLOADING	Fast unload screw compressor at start up.
CMP IS LOADING	Pulsing screw load solenoid
CMP IS HOLDING	Control temperature with in target control band,
CMP IS UNLNDING	Pulsing screw unload solenoid
HI DISC UNLOAD	Pulse screw unload solenoid because discharge temp or pressure is too high
HI DISC HOLD	Holding until discharge temp or pressure returns to normal
LO SUCT UNLOAD	Pulse screw unload solenoid or unload 1 step, suction temp or pressure is too low
LO SUCT HOLD	Holding screw slide or 1 unloader off until suction temp or pressure returns to normal
LO TEMP UNLOAD	Comp unloading, temperature less than 1.5 F above freeze point.
LO TEMP HOLD	Hold until temperature is 3.0 F above freezing point.
CMP UNLOADED	Comp ON, all unloaders OFF
CMP IS AT 100%	Circuit is fully loaded, all unloaders are OFF
CMP PUMP DOWN	Pumping down
CMP ANTICYCLE	Delay after turning off circuit
SWITCHED OFF	Pump down switch on or system state is DISABLE
SAFETY TRIPPED	Safety tripped not LOCKOUT
CMP LOCKED OUT	Safety tripped twice with in half hour, circuit locked off
LOST IO LOCKED	Lost communication
HI AMP HOLD	Circuit is in hold due to hi amps. Can only be unloaded.

19. OEM Factory Checkout Procedure

19.1. Visual Check

- Control power wiring correct and 120 / 240 selector switch set correctly.
- Jumper settings
 - Sensor input
 - MCS I/O communication termination
 - MCS communication termination
 - EEPROM write protection
- Sensor Wiring
- MCS-IO Communication Wiring
- LCD Connector (dot to mark on the board)
- Keypad Connector (dot to mark on the board)
- RO Wiring

Ensure that the EMG stop is on (closed position) or run/stop input off so that the unit will not run after power applied to micro.

19.2. MCS Power On (Compressor Power off)

- MCS System on
- LCD on and valid display MCS Logo or Logo in configuration then Main Menu screen
- Communications light blinking if I/O units
- Get AUTHORIZED
- Check sensor readings
- Manually bump (on then off) each point (take care your in control)

20. Compressor relay output sequence examples (software)

The sequence of the relay outputs is critical and must be set up as show in the following examples. If any optional relays are not required, then the following relays move up in the sequence so that no relays are skipped or wasted.

20.1. HANBELL Compressor with NO

The example below has one compressor with a split-winding starter, hot gas bypass, liquid injection and a second liquid line solenoid.

- COMP 1A Compressor 1A contactor
- COMP 1B (Optional) Compressor 1B contactor (split-winding starts 1 sec. after A)
- LOAD 1 Loads slide (wired to normal closed)
- UNLD 1 Unloads slide (wired to normal open)
- LLS SML Liquid line solenoid
- HGB1 (Optional) Hot gas bypass
- LIQ INJ1 (Optional) Liquid injection solenoid

20.2. HANBELL Compressor with NC

The example below has one compressor without a split-winding starter and with hot gas bypass.

- COMP 1A Compressor 1A contactor
- LOAD 1 Loads slide (wired to normal closed)
- UNLD 1 Unloads slide (wired to normal open)
- LLS SML Liquid line solenoid
- HGB1 (Optional) Hot gas bypass

20.3. HANBELL Compressor with 3 Solenoids

The example below has one compressor without a split-winding starter.

- COMP 1A Compressor 1A contactor
- LOAD 1 Loads slide
- UNLD 1 Unloads slide
- FAST UNLOAD Fast Unload solenoid for slide valve
- LLS Liquid line solenoid

20.4. Centrifugal Compressor

The example below has one compressor with a star-delta starter, Oil pump, and Oil heater, Hot gas By-Pass, Liquid Injection, Oil equalization and an Oil Cooler solenoid.

- COMP 1A Compressor 1A contactor
- COMP 1B (Optional) Compressor 1B contactor (split-winding starts 1 sec. after A)
- LOAD 1 Load Solenoid-on load slide
- UNLD 1 Unload Solenoid-on load slide
- OIL PMP1 Oil pump
- OIL HTR1 Oil Heater
- HGB1 (Optional) Hot Gas By-Pass
- LIQ INJ1 (Optional) Liquid Injection
- FAST UNLOAD (Optional) Fast Unload solenoid for slide valve
- OIL EQL (Optional) Oil equalization
- OIL COOLER (Optional) Oil cooler solenoid

20.5. Mitsubishi Mono Screw

The example below has one compressor with a split-winding starter, capability to load solenoid at 40% and 70%, and a liquid line solenoid.

- COMP 1A Compressor 1A contactor
- COMP 1B (Optional) Compressor 1B contactor (split-winding starts 1 sec. after A)
- FAST UNLOAD Fast unload solenoid for slide valve
- 40% LOAD 40% capacity load solenoid
- 70% LOAD 70% capacity load solenoid

- LLS 1 (Optional) Liquid Line Solenoid

20.6. Screw Compressor With Oil

The example below has one compressor with a split-winding starter, second liquid line solenoid, liquid injection, hot gas bypass, oil equalization, oil cooler solenoid, and a low discharge superheat warning.

- COMP 1A Compressor 1A contactor
- COMP 1B (Optional) Compressor 1B contactor (split-winding starts 1 sec. after A)
- LOAD 1 Load Solenoid-on load slide
- UNLD 1 Unload Solenoid-on load slide
- OIL PMP1 Oil pump
- OIL HTR1 Oil heater
- LLS 1 (Optional) Liquid line solenoid
- HGB1 (Optional) Hot gas bypass
- LIQ INJ1 (Optional) Liquid injection solenoid
- FAST UNLOAD (Optional) Fast unload solenoid for slide valve
- LLS LRGE (Optional) Large liquid line
- OIL EQL (Optional) Oil equalization
- OIL COOLER (Optional) Oil cooler solenoid
- LOWDISC SHEAT (Optional) Low discharge superheat warning output

20.7. Reciprocating Compressor

The example below has one compressor without a split-winding starter and 3 unloaders.

- COMP 1A Compressor 1A contactor
- LLS Liquid line solenoid
- UNLD 1-1 Unloader stage 1 (25% load)
- UNLD 1-2 Unloader stage 2 (75% load)
- UNLD 1-3 Unloader stage 3 (100% load)

20.8. JE HALL Screw Compressor With Split-winding

The example below has one compressor with a split-winding starter, second liquid line solenoid, liquid injection, hot gas bypass, oil equalization and oil cooler solenoid.

- COMP 1A Compressor 1A contactor
- COMP 1B (Optional) Compressor 1B contactor (split-winding starts 1 sec. after A)
- LOAD 3-1 Loads (provides 25 to 50%, or provides 75 to 100% depending on position of Load1-1)
- UNLD 2-1 Unloads
- LOAD 1-1 OFF 25 to 50 % capacity, ON 75 to 100 %
- LLS SML Liquid line solenoid
- HGB1 (Optional) Hot gas bypass
- LIQ INJ1 (Optional) Liquid injection solenoid
- STRT ULD (Optional) Start unload
- LLS LRGE (Optional) Large liquid line
- OIL EQL (Optional) Oil equalization
- OIL COOLER (Optional) Oil cooler solenoid

20.9. HITACHI Screw Compressor

The example below has one compressor with a split-winding starter, start unloader, second liquid line solenoid, liquid injection, hot gas bypass, oil equalization and oil cooler solenoid.

- COMP 1A Compressor 1A contactor
- COMP 1B (Optional) Compressor 1B contactor (split-winding starts 1 sec. after A)
- LOAD 1 Loads slide
- UNLD 1 Unloads slide
- S UNLD 1 Start unloader
- LLS SML Liquid line solenoid

- HGS 1 (Optional) Hot gas solenoid
- LLS LRGE (Optional) Large liquid line
- OIL EQL (Optional) Oil equalization
- OIL COOLER (Optional) Oil cooler solenoid

20.10. HARTFORD Compressor (Vertical)

The example below has one compressor with a split-winding starter, second liquid line solenoid, liquid injection, hot gas bypass, oil equalization and oil cooler solenoid.

- COMP 1A Compressor 1A contactor
- COMP 1B (Optional) Compressor 1B contactor (split-winding starts 1 sec. after A)
- LOAD 1 Loads slide.
- UNLD 1 Liquid line solenoid (wired to normal closed)
- HGB1 (Optional) Hot gas bypass
- LIQ INJ1 (Optional) Liquid injection solenoid
- LLS LRGE (Optional) Large liquid line
- OIL EQL (Optional) Oil equalization
- OIL COOLER (Optional) Oil cooler solenoid

20.11. Bitzer Compressor

The example below has one compressor and one step of capacity with a two-stage condenser fan.

- COMP 1A Compressor 1A contactor
- LOAD 1 Loads slide.
- UNLD 1 Unloads slide
- LLS 1 Liquid line solenoid
- SPARE Not used
- CND FAN 1 Condenser fan stage 1
- CND FAN 2 Condenser fan stage 2

21. The Magnum Keypad Display Quick Reference

- No authorization is required to displaying information.
- Pressing the 'MENU' key will display the information below.
- Using the ←, ↑, →, ↓ position the cursor on the item you want.
- Press the ↵ (ENTER) key to display item
- The bottom line of the display defines the current functions. For Passwords use the numbers on the keys. (1 thru 8)
- The RS 232 connector is located at the bottom of the keypad.
- To use MCS-Connect you need to use a MCS-PC9 cable.

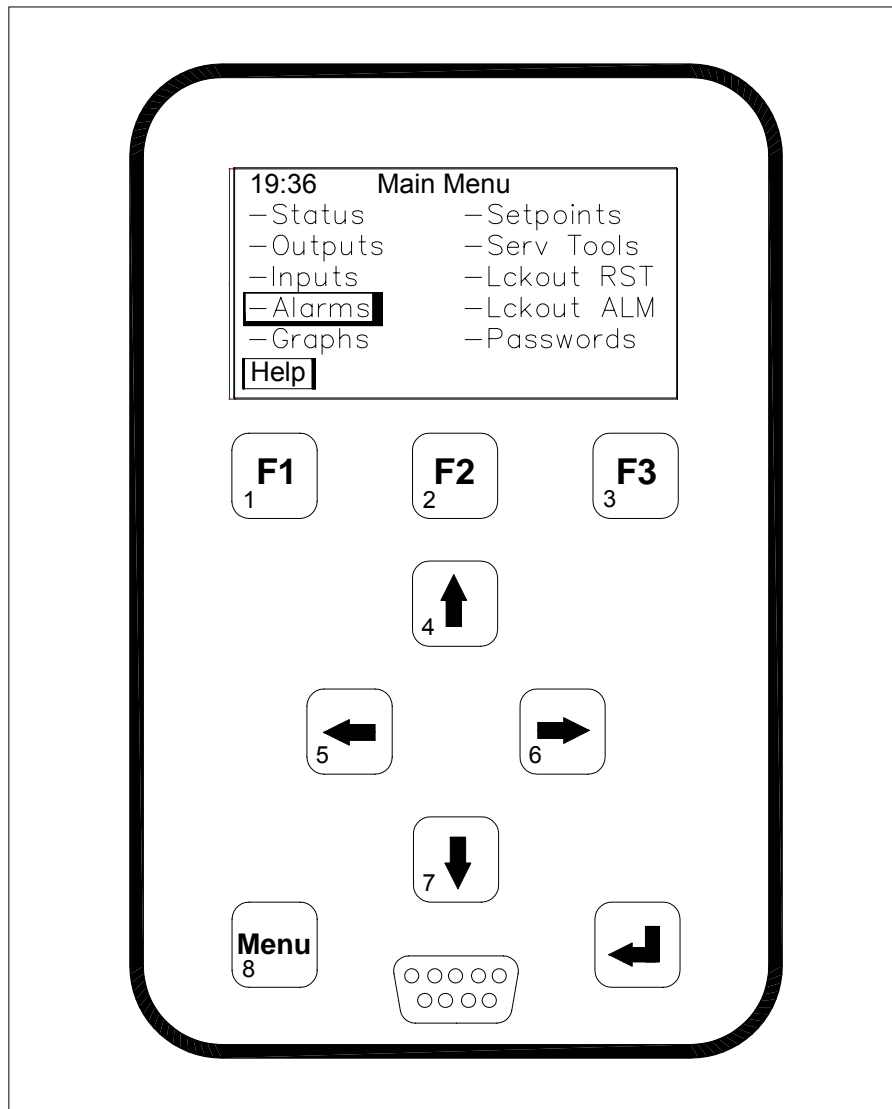

22. The MAGNUM Hardware Rev 1 thru 5 Quick Reference Sheet

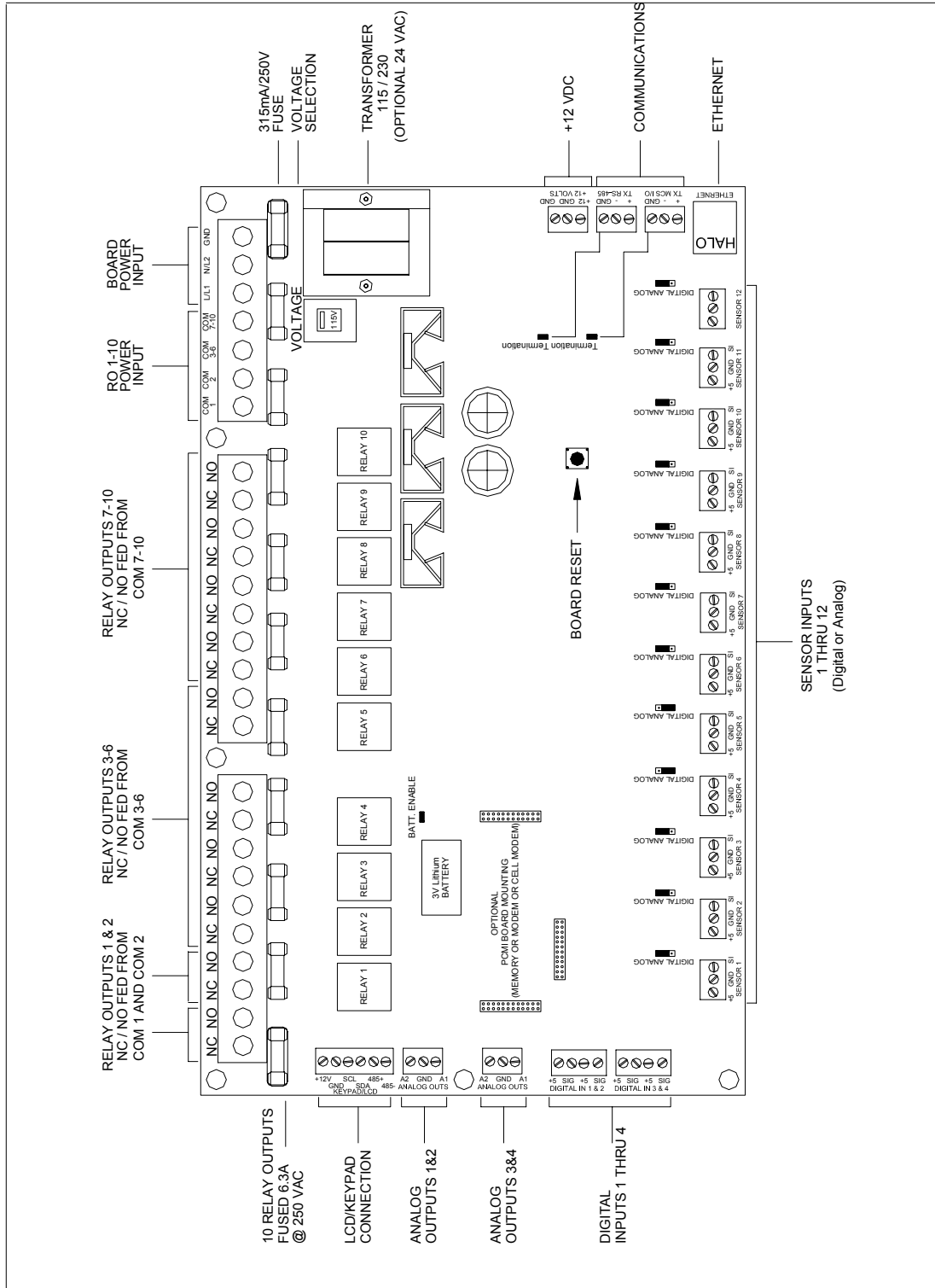

23. The MAGNUM Hardware Rev 1 thru 5 Quick Reference Sheet (Relay Output Block Details)

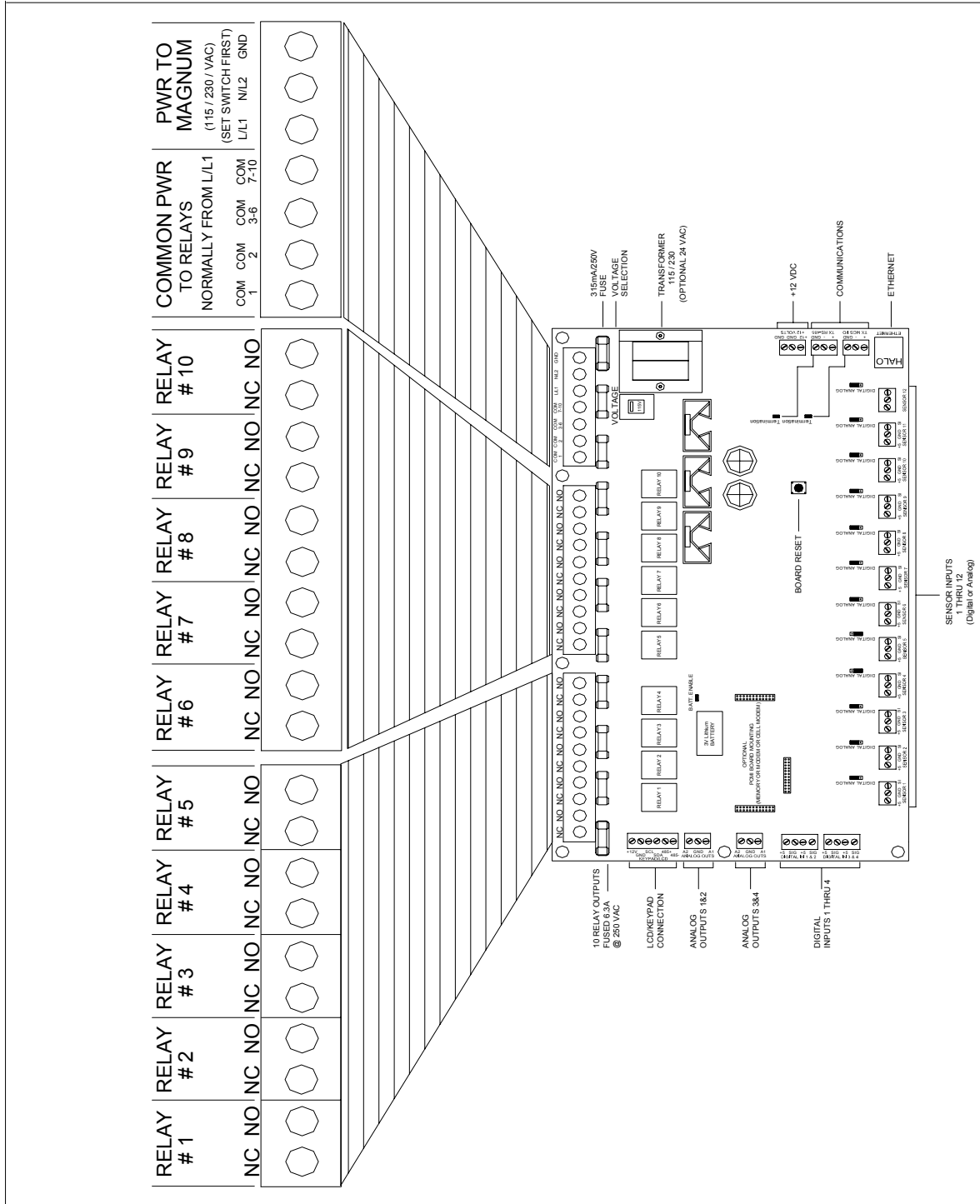

25. The MCS Sensors Quick Reference Sheet (Temp & Humidity)

MCS-T100 (SI #1 through 12 on MCS-MAGNUM or SI 16)

1. Connects to 1 of MCS Sensor Inputs 1 thru 12 or SI 16
2. Shielded cable GND drain must be connected to SI 'GND'
3. Temp MCS-MAGNUM- SI (inputs 1-12) jumper setting is ANALOG'

MCS Sensor Input Terminal Strips

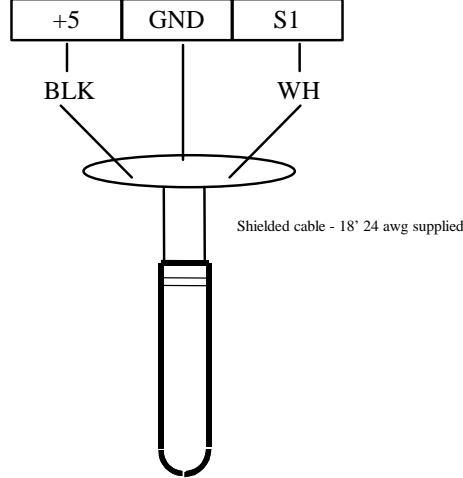

MCS-T100

MCS-ZONE (SI #1 through 12 on MCS-MAGNUM or SI 16)

1. Connects to 1 of MCS Sensor Inputs 1 thru 12 or SI 16
2. Shielded cable GND drain must be connected to SI 'GND'
3. Temp MCS-MAGNUM SI (inputs 1-12) jumper setting is 'ANALOG'

MCS Sensor Input Terminal Strips SENSOR (x)

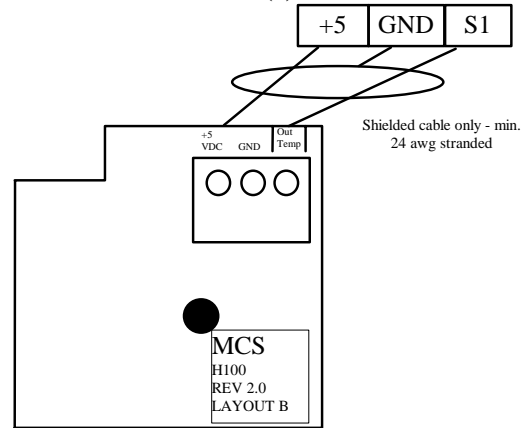

MCS-ZONE

MCS-SAIR (SI #1 through 12 on Magnum or SI 16)

1. Connects to 1 of MCS-MAGNUM Sensor Inputs 1-12 or SI 16
2. Shielded cable GND drain must be connected to SI GND
3. Temp on MCS-MAGNUM- SI (input 1-12) or SI 16 jumpers setting to analog
4. Minimum extension inside duct 2.25"
5. Normal extension, as shown, 4.00"

MCS Sensor Input Terminal Strips

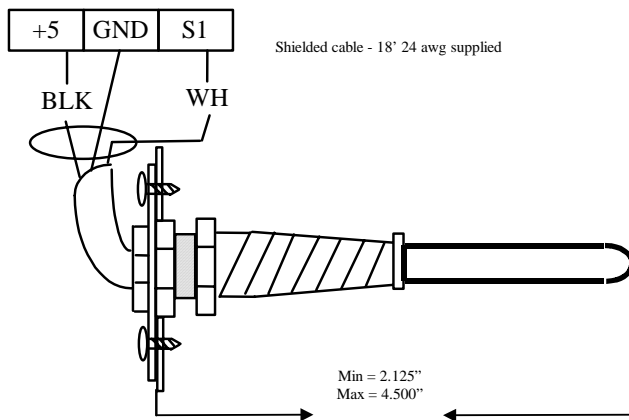

MCS-SAIR

MCS-HUMD (SI #1 through 12 on Magnum or SI 16)

1. Connects to 2 of MCS-MAGNUM Sensor Inputs 1 -12 or SI 16
2. Humidity MCS-MAGNUM-SI (input 1-8) jumper setting to analog
3. +5 vdc & GND are common (only one connection required)
4. Temp. on MCS-MAGNUM-SI (input 1-12) or SI 16 jumper setting is analog
5. Shielded cable GND drain must be connected to SI 'GND'

MCS Sensor Input Terminal Strips +12 OUT SENSOR (x1) SENSOR(x2)

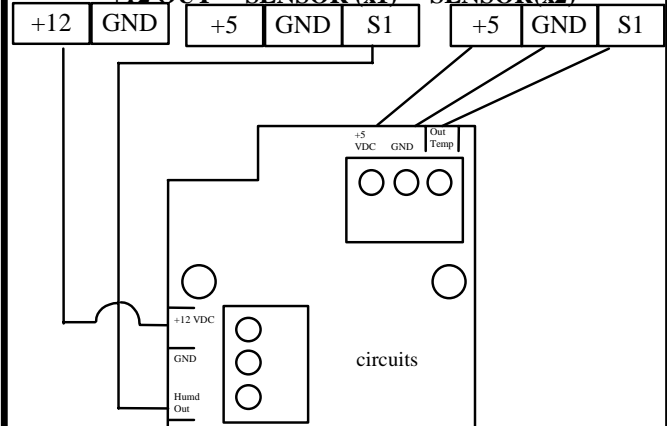

MCS-H100

26. The MCS Sensors Quick Reference Sheet (PSI, CT & Digital)

TI-500-xx (SI #1 thru 12 on MCS-MAGNUM or SI 16)

1. TI-500-xx pressure transducer (3 wire 0-5 vdc)
2. Wiring for 3 wire to SI# 1 through 12 or on SI 16
3. Jumper settings for SI is 'ANALOG'
4. Pressure range 0 - 500 psi

MCS Sensor Input Terminal Strips SENSOR (x)

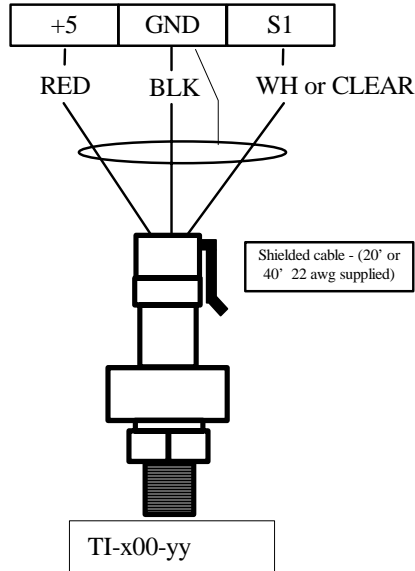

Dry Contact's on MCS-MAGNUM

1. Digital inputs for use on sensor inputs (SI 1-16)
2. Dry Contact MCS-MAGNUM SI (inputs 1-12) jumper setting is 'DIGITAL'
3. Dry Contact MCS-MAGNUM SI (inputs 13-16) Digital only
4. Verify on 'INPUTS Display on keypad
5. Shielded cable GND drain must be connected to SI GND"

MCS Sensor Input Terminal Strips Sensor (x)

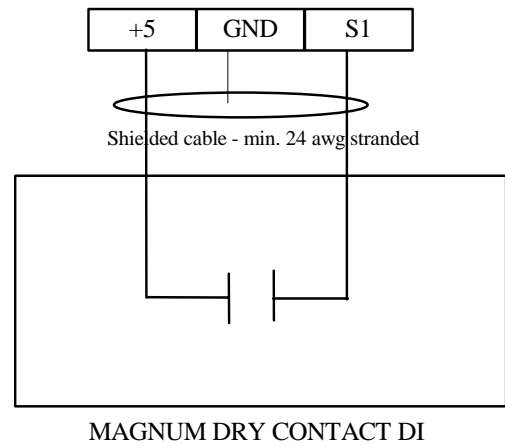

MCS-CT-xxx (SI #1 through 12 on Magnum or SI 16)

1. Connect to MCS-MAGNUM sensor inputs 1 thru 12 or SI 16
2. The current transformer may be 100:0.5, 250:0.5, 500:0.5
3. AMPS jumper setting is 'ANALOG'
4. For wiring only remove terminal block from CT.
5. DO NOT REMOVE PRINTED CIRCUIT BOARD.
6. DO NOT WIRE +5 FROM MAGNUM OR SI 16

MCS Sensor Input Terminal Strip Sensor (x)

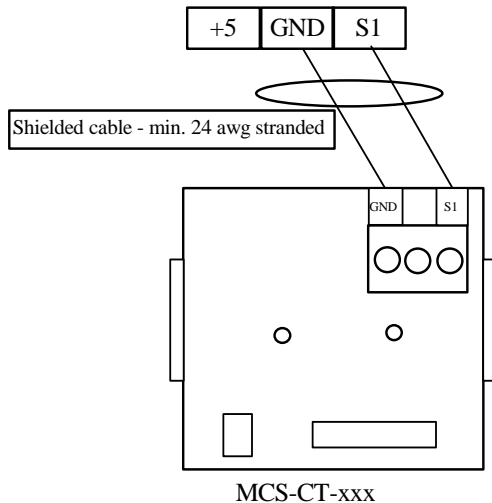

27. The MCS Trouble Shooting Quick Reference Sheet

(Complete trouble shooting write up is available on web site www.MCScontrols.com)

PROBLEM	POTENTIAL SOLUTION
No Sensor + 5 vdc or sensor +5 vdc less than 4.90 vdc.	<ul style="list-style-type: none"> Indicates a possible shorted input sensor Remove all sensor terminal blocks. Wait about 30 to 60 seconds. If + 5 vdc returns, replace one sensor wire at a time until the + 5 vdc is lost again. This will be the shorted sensor.
A sensor input reads -99.9	<p>This indicates an open sensor input signal or 5 VDC problem.</p> <ul style="list-style-type: none"> Check sensor wiring for missing wire or poor connection. Check sensor for bad sensor. Check + 5 vdc on sensor input to ground. If less than 5 VDC is on the sensor 5 VDC terminal block, the problem is with probably a shorted sensor. (A poly fuse protects the board) <p>- Remove all sensor input terminals. - Wait about 1 min. or until 5 VDC restored at sensor input. - Connect terminals 1 at time until short reappears & fix bad sensor.</p>
A sensor input reads +999.9	<p>This indicates a shorted sensor input signal.</p> <ul style="list-style-type: none"> Check sensor wiring for +5VDC shorted to signal etc. Check sensor for bad sensor.
A pressure sensor is reading more than 1 psi off (The temperature & humidity sensors do not require calibration.)	<p>This indicates the transducer sensor input needs to be calibrated via the offset capability in the software. (Transducers by design need to be calibrated based on construction and altitude.)</p> <ul style="list-style-type: none"> You need to have a valid Auth code to change sensor offsets You must use the Windows based software package 'MCS-Connect' See MCS-Connect' Interactive section for instructions. ('Change SI Status, Manual Value and / or offset.)
Invalid reading on one sensor input.	<p>This indicates an input problem with 1 sensor.</p> <ul style="list-style-type: none"> Verify jumper settings correct for that SI.
'MCS CONTROLLER INITIALIZATION' on LCD display.	<p>Indicates Micro in constant reset.</p> <ul style="list-style-type: none"> Check incoming power > 105 VAC or 22 VAC
Top row of LCD display all bars & 2nd row blank.	<p>Indicates software chip problem possible.</p> <ul style="list-style-type: none"> Possible U11 software version incorrect or chip bad. Possible U13 GAL chip incorrect or chip bad. Possible bad connection or cable between LCD and MCS8
LCD blank.	<p>Indicates bad connection.</p> <ul style="list-style-type: none"> Connector J2 on MCS not on or offset on connector. Resistor adjustment VR1 out of adjustment.
Lost I/O	<p>Indicates communications problem.</p> <ul style="list-style-type: none"> Verify RS485 LED blinking. Verify termination jumper J6 only on at MAGNUM & last I/O. Verify MAGNUM & I/O address's set correctly. Verify wiring from MAGNUM to each I/O correct. Check fuses/120 VAC on I/O units
Changes to MCS not being made from the unit's keypad.	<p>This indicates inability to write to chip U10.</p> <ul style="list-style-type: none"> Verify 'EEP WRITE ENABLE' jumper W6 is on. Not authorized
MCS-Connect– cannot make changes	<p>This indicates you are not at a proper authorization level. Follow steps below for proper authorization</p>

PROBLEM	POTENTIAL SOLUTION
	<ul style="list-style-type: none"> • From either the SYSTEM INFO or STATUS screen, under MCS-Connect, click on the 'AUTH' button on the lower right of your LCD display. • Follow prompts and enter a valid 4-digit authorization number. • The authorization level is displayed at the top of the display and is reflected via the color of the AUTH button. <ol style="list-style-type: none"> 1. RED = view only 2. YELLOW = service level 3. BLUE = Supervisor level 4. Green = Factory level
Invalid authorization	<p>This indicates an invalid auth number. Follow steps below for proper authorization</p> <ul style="list-style-type: none"> • Press SERVICE DIAGNOSTICS key until the authorization option appears • Press the ENTER key • From the "Display Status" press keys corresponding to your authorization number. • Press ENTER
SI from AMPS board 10 A low.	<p>This indicates a problem with this SI only.</p> <ul style="list-style-type: none"> • Jumper setting on this SI in wrong position. • Incorrect sensor type used.
INVALID CONFIG VER	<p>Indicates layout of CFG wrong.</p> <ul style="list-style-type: none"> • CFG layout for different version than software
INVALID CONFIG TYPE	<p>Indicates CFG incompatible with software.</p>
INVALID CONFIG CHECKSUM	<p>Indicates Checksum invalid</p> <ul style="list-style-type: none"> • Reload a valid CFG
Sensor input believed invalid (Under Sensor Diagnostic Sub Menu)	<ul style="list-style-type: none"> • Verify Berg jumpers using Quick Reference Sheets • Check board version number • Check wiring of sensor
Communications to MCS-485-GATEWAY from MCS-Connect not working.	<ul style="list-style-type: none"> • Verify red LED on the gate way is blinking. This indicates that the MCS-Connect program is talking to the gateway. • Verify that the two wire shielded cable is properly wired from the RS-485 connector to the gateway. • Verify red LED (Located just to he left of the RS-485 connector on the MAGNUM board is blinking. This indicates that the MAGNUM is responding to the gateway. • If both of these LED are blinking, check the address of the MAGNUM and any other MAGNUMs that are on the network. Each must have a unique address. This address can be changed from the MAGNUM. Proper authorization is required. Enter the UNIT INFORMATION screen by depressing the SERVICE DIAGNOSTIC key and scrolling to this item. Depress the ENTER key and scroll to the NETWORK ADDRESS screen. Change address if needed. • Verify + 12 vdc to MCS-485-GATEWAY
INVALID CONFIG	<p>Indicates Checksum invalid</p> <ul style="list-style-type: none"> • Either set to factory defaults on reset settings.

28. BMS Communication Protocols

SW Version 5.06C and greater

MAGNUM supports BACnet MSTP, BACnet IP, Modbus RTU, Modbus TCP/IP, and Johnson N2. Supported baud rates for BACNET MSTP are 9600bps, 19200bps, 38400bps, and 76800bps. Supported baud rates for Modbus RTU are 4800bps, 9600bps, 19200bps, 38400bps, and 57600bps.

28.1. Sensor Input Points

All other sensor input types are read-only.

Notable BACnet properties available: Units

Magnum	BACnet ID	BACnet Name	Modbus Register	N2
Sensor M - 1	AI: 1	Refer to Config	*30001	*AI: 1
Sensor M - 2	AI: 2	Refer to Config	*30002	*AI: 2
Sensor M - 3	AI: 3	Refer to Config	*30003	*AI: 3
Sensor M - 4	AI: 4	Refer to Config	*30004	*AI: 4
Sensor M - 5	AI: 5	Refer to Config	*30005	*AI: 5
Sensor M - 6	AI: 6	Refer to Config	*30006	*AI: 6
Sensor M - 7	AI: 7	Refer to Config	*30007	*AI: 7
Sensor M - 8	AI: 8	Refer to Config	*30008	*AI: 8
Sensor M - 9	AI: 9	Refer to Config	*30009	*AI: 9
Sensor M-10	AI:10	Refer to Config	*30010	*AI: 10
Sensor M-11	AI:11	Refer to Config	*30011	*AI: 11
Sensor M-12	AI:12	Refer to Config	*30012	*AI: 12
Sensor M-13	AI:13	Refer to Config	*30013	*AI: 13
Sensor M-14	AI:14	Refer to Config	*30014	*AI: 14
Sensor M-15	AI:15	Refer to Config	*30015	*AI: 15
Sensor M-16	AI:16	Refer to Config	*30016	*AI: 16
Sensor 1 - 1	AI:17	Refer to Config	*30017	*AI: 17
Sensor 1 - 2	AI:18	Refer to Config	*30018	*AI: 18
Sensor 1 - 3	AI:19	Refer to Config	*30019	*AI: 19
Sensor 1 - 4	AI:20	Refer to Config	*30020	*AI: 20
Sensor 1 - 5	AI:21	Refer to Config	*30021	*AI: 21
Sensor 1 - 6	AI:22	Refer to Config	*30022	*AI: 22
Sensor 1 - 7	AI:23	Refer to Config	*30023	*AI: 23
Sensor 1 - 8	AI:24	Refer to Config	*30024	*AI: 24
Sensor 2 - 1	AI:25	Refer to Config	*30025	*AI: 25
Sensor 2 - 2	AI:26	Refer to Config	*30026	*AI: 26
Sensor 2 - 3	AI:27	Refer to Config	*30027	*AI: 27
Sensor 2 - 4	AI:28	Refer to Config	*30028	*AI: 28
Sensor 2 - 5	AI:29	Refer to Config	*30029	*AI: 29
Sensor 2 - 6	AI:30	Refer to Config	*30030	*AI: 30
Sensor 2 - 7	AI:31	Refer to Config	*30031	*AI: 31
Sensor 2 - 8	AI:32	Refer to Config	*30032	*AI: 32
Sensor 3 - 1	AI:33	Refer to Config	*30033	*AI: 33

Magnum	BACnet ID	BACnet Name	Modbus Register	N2
Sensor 3 - 2	AI:34	Refer to Config	*30034	*AI: 34
Sensor 3 - 3	AI:35	Refer to Config	*30035	*AI: 35
Sensor 3 - 4	AI:36	Refer to Config	*30036	*AI: 36
Sensor 3 - 5	AI:37	Refer to Config	*30037	*AI: 37
Sensor 3 - 6	AI:38	Refer to Config	*30038	*AI: 38
Sensor 3 - 7	AI:39	Refer to Config	*30039	*AI: 39
Sensor 3 - 8	AI:40	Refer to Config	*30040	*AI: 40
Sensor 4 - 1	AI:41	Refer to Config	*30041	*AI: 41
Sensor 4 - 2	AI:42	Refer to Config	*30042	*AI: 42
Sensor 4 - 3	AI:43	Refer to Config	*30043	*AI: 43
Sensor 4 - 4	AI:44	Refer to Config	*30044	*AI: 44
Sensor 4 - 5	AI:45	Refer to Config	*30045	*AI: 45
Sensor 4 - 6	AI:46	Refer to Config	*30046	*AI: 46
Sensor 4 - 7	AI:47	Refer to Config	*30047	*AI: 47
Sensor 4 - 8	AI:48	Refer to Config	*30048	*AI: 48

*- Indicates value multiplied by 10 to include one decimal place. (ie. BMS value of 500 indicates actual value 50.0)

28.2. Relay Output Points

Relay output points are read-only.

Magnum	BACnet ID	BACnet Name	Modbus	N2
Relay M - 1	BO: 1	Refer to Config	00001	BO: 1
Relay M - 2	BO: 2	Refer to Config	00002	BO: 2
Relay M - 3	BO: 3	Refer to Config	00003	BO: 3
Relay M - 4	BO: 4	Refer to Config	00004	BO: 4
Relay M - 5	BO: 5	Refer to Config	00005	BO: 5
Relay M - 6	BO: 6	Refer to Config	00006	BO: 6
Relay M - 7	BO: 7	Refer to Config	00007	BO: 7
Relay M - 8	BO: 8	Refer to Config	00008	BO: 8
Relay M - 9	BO: 9	Refer to Config	00009	BO: 9
Relay M-10	BO:10	Refer to Config	00010	BO: 10
Relay 1 - 1	BO:11	Refer to Config	00011	BO: 11
Relay 1 - 2	BO:12	Refer to Config	00012	BO: 12
Relay 1 - 3	BO:13	Refer to Config	00013	BO: 13
Relay 1 - 4	BO:14	Refer to Config	00014	BO: 14
Relay 1 - 5	BO:15	Refer to Config	00015	BO: 15
Relay 1 - 6	BO:16	Refer to Config	00016	BO: 16
Relay 1 - 7	BO:17	Refer to Config	00017	BO: 17
Relay 1 - 8	BO:18	Refer to Config	00018	BO: 18
Relay 2 - 1	BO:19	Refer to Config	00019	BO: 19
Relay 2 - 2	BO:20	Refer to Config	00020	BO: 20
Relay 2 - 3	BO:21	Refer to Config	00021	BO: 21
Relay 2 - 4	BO:22	Refer to Config	00022	BO: 22

Magnum	BACnet ID	BACnet Name	Modbus	N2
Relay 2 - 5	BO:23	Refer to Config	00023	BO: 23
Relay 2 - 6	BO:24	Refer to Config	00024	BO: 24
Relay 2 - 7	BO:25	Refer to Config	00025	BO: 25
Relay 2 - 8	BO:26	Refer to Config	00026	BO: 26
Relay 3 - 1	BO:27	Refer to Config	00027	BO: 27
Relay 3 - 2	BO:28	Refer to Config	00028	BO: 28
Relay 3 - 3	BO:29	Refer to Config	00029	BO: 29
Relay 3 - 4	BO:30	Refer to Config	00030	BO: 30
Relay 3 - 5	BO:31	Refer to Config	00031	BO: 31
Relay 3 - 6	BO:32	Refer to Config	00032	BO: 32
Relay 3 - 7	BO:33	Refer to Config	00033	BO: 33
Relay 3 - 8	BO:34	Refer to Config	00034	BO: 34
Relay 4 - 1	BO:35	Refer to Config	00035	BO: 35
Relay 4 - 2	BO:36	Refer to Config	00036	BO: 36
Relay 4 - 3	BO:37	Refer to Config	00037	BO: 37
Relay 4 - 4	BO:38	Refer to Config	00038	BO: 38
Relay 4 - 5	BO:39	Refer to Config	00039	BO: 39
Relay 4 - 6	BO:40	Refer to Config	00040	BO: 40
Relay 4 - 7	BO:41	Refer to Config	00041	BO: 41
Relay 4 - 8	BO:42	Refer to Config	00042	BO: 42
Relay 5 - 1	BO:43	Refer to Config	00043	BO: 43
Relay 5 - 2	BO:44	Refer to Config	00044	BO: 44
Relay 5 - 3	BO:45	Refer to Config	00045	BO: 45
Relay 5 - 4	BO:46	Refer to Config	00046	BO: 46
Relay 5 - 5	BO:47	Refer to Config	00047	BO: 47
Relay 5 - 6	BO:48	Refer to Config	00048	BO: 48

28.3. Analog Output Points

Analog Output points are read-only.

Notable BACnet properties available: Units

Magnum	BACnet ID	BACnet Name	Modbus Register	N2
Analog Out M-1	AO:1	Refer to Config	*30201	*AO: 1
Analog Out M-2	AO:2	Refer to Config	*30202	*AO: 2
Analog Out M-3	AO:3	Refer to Config	*30203	*AO: 3
Analog Out M-4	AO:4	Refer to Config	*30204	*AO: 4
Analog Out 1-1	AO:5	Refer to Config	*30205	*AO: 5
Analog Out 1-2	AO:6	Refer to Config	*30206	*AO: 6
Analog Out 2-1	AO:7	Refer to Config	*30207	*AO: 7
Analog Out 2-2	AO:8	Refer to Config	*30208	*AO: 8
Analog Out 3-1	AO:9	Refer to Config	*30209	*AO: 9
Analog Out 3-2	AO:10	Refer to Config	*30210	*AO: 10
Analog Out 4-1	AO:11	Refer to Config	*30211	*AO: 11

Magnum	BACnet ID	BACnet Name	Modbus Register	N2
Analog Out 4-2	AO:12	Refer to Config	*30212	*AO: 12

*- Indicates value multiplied by 10 to include one decimal place. (ie. BMS value of 500 indicates actual value 50.0)

28.4. Set Points

Set Points are read-only.

Notable BACnet properties available: Units, High-Limit, Low-Limit

Magnum	BACnet ID	BACnet Name	Modbus	N2
Set point #1	AV:0	STP# 1-<Set point name>	40301	ADF:1
Set point #2	AV:1	STP# 2-<Set point name>	40302	ADF:2
Set point #3	AV:2	STP# 3-<Set point name>	40303	ADF:3
Set point #4	AV:71	STP# 4-<Set point name>	40304	ADF:72
Set point #5	AV:72	STP# 5-<Set point name>	40305	ADF:73
Set point #6	AV:73	STP# 6-<Set point name>	40306	ADF:74
Set point #7	AV:74	STP# 7-<Set point name>	40307	ADF:75
Set point #8	AV:75	STP# 8-<Set point name>	40308	ADF:76
Set point #9	AV:76	STP# 9-<Set point name>	40309	ADF:77
Set point #10	AV:77	STP# 10-<Set point name>	40310	ADF:78
Set point #11	AV:78	STP# 11-<Set point name>	40311	ADF:79
Set point #12	AV:79	STP# 12-<Set point name>	40312	ADF:80
Set point #13	AV:80	STP# 13-<Set point name>	40313	ADF:81
Set point #14	AV:81	STP# 14-<Set point name>	40314	ADF:82
Set point #15	AV:82	STP# 15-<Set point name>	40315	ADF:83
Set point #16	AV:83	STP# 16-<Set point name>	40316	ADF:84
Set point #17	AV:84	STP# 17-<Set point name>	40317	ADF:85
Set point #18	AV:85	STP# 18-<Set point name>	40318	ADF:86
Set point #19	AV:86	STP# 19-<Set point name>	40319	ADF:87
Set point #20	AV:87	STP# 20-<Set point name>	40320	ADF:88
Set point #21	AV:88	STP# 21-<Set point name>	40321	ADF:89
Set point #22	AV:89	STP# 22-<Set point name>	40322	ADF:90
Set point #23	AV:90	STP# 23-<Set point name>	40323	ADF:91
Set point #24	AV:91	STP# 24-<Set point name>	40324	ADF:92
Set point #25	AV:92	STP# 25-<Set point name>	40325	ADF:93
Set point #26	AV:93	STP# 26-<Set point name>	40326	ADF:94
Set point #27	AV:94	STP# 27-<Set point name>	40327	ADF:95
Set point #28	AV:95	STP# 28-<Set point name>	40328	ADF:96
Set point #29	AV:96	STP# 29-<Set point name>	40329	ADF:97
Set point #30	AV:97	STP# 30-<Set point name>	40330	ADF:98
Set point #31	AV:98	STP# 31-<Set point name>	40331	ADF:99
Set point #32	AV:99	STP# 32-<Set point name>	40332	ADF:100
Set point #33	AV:100	STP# 33-<Set point name>	40333	ADF:101
Set point #34	AV:101	STP# 34-<Set point name>	40334	ADF:102
Set point #35	AV:102	STP# 35-<Set point name>	40335	ADF:103

Magnum	BACnet ID	BACnet Name	Modbus	N2
Set point #36	AV:103	STP# 36-<Set point name>	40336	ADF:104
Set point #37	AV:104	STP# 37-<Set point name>	40337	ADF:105
Set point #38	AV:105	STP# 38-<Set point name>	40338	ADF:106
Set point #39	AV:106	STP# 39-<Set point name>	40339	ADF:107
Set point #40	AV:107	STP# 40-<Set point name>	40340	ADF:108
Set point #41	AV:108	STP# 41-<Set point name>	40341	ADF:109
Set point #42	AV:109	STP# 42-<Set point name>	40342	ADF:110
Set point #43	AV:110	STP# 43-<Set point name>	40343	ADF:111
Set point #44	AV:111	STP# 44-<Set point name>	40344	ADF:112
Set point #45	AV:112	STP# 45-<Set point name>	40345	ADF:113
Set point #46	AV:113	STP# 46-<Set point name>	40346	ADF:114
Set point #47	AV:114	STP# 47-<Set point name>	40347	ADF:115
Set point #48	AV:115	STP# 48-<Set point name>	40348	ADF:116
Set point #49	AV:116	STP# 49-<Set point name>	40349	ADF:117
Set point #50	AV:117	STP# 50-<Set point name>	40350	ADF:118
Set point #51	AV:118	STP# 51-<Set point name>	40351	ADF:119
Set point #52	AV:119	STP# 52-<Set point name>	40352	ADF:120
Set point #53	AV:120	STP# 53-<Set point name>	40353	ADF:121
Set point #54	AV:121	STP# 54-<Set point name>	40354	ADF:122
Set point #55	AV:122	STP# 55-<Set point name>	40355	ADF:123
Set point #56	AV:123	STP# 56-<Set point name>	40356	ADF:124
Set point #57	AV:124	STP# 57-<Set point name>	40357	ADF:125
Set point #58	AV:125	STP# 58-<Set point name>	40358	ADF:126
Set point #59	AV:126	STP# 59-<Set point name>	40359	ADF:127
Set point #60	AV:127	STP# 60-<Set point name>	40360	ADF:128
Set point #61	AV:128	STP# 61-<Set point name>	40361	ADF:129
Set point #62	AV:129	STP# 62-<Set point name>	40362	ADF:130
Set point #63	AV:130	STP# 63-<Set point name>	40363	ADF:131
Set point #64	AV:131	STP# 64-<Set point name>	40364	ADF:132
Set point #65	AV:132	STP# 65-<Set point name>	40365	ADF:133
Set point #66	AV:133	STP# 66-<Set point name>	40366	ADF:134
Set point #67	AV:134	STP# 67-<Set point name>	40367	ADF:135
Set point #68	AV:135	STP# 68-<Set point name>	40368	ADF:136
Set point #69	AV:136	STP# 69-<Set point name>	40369	ADF:137
Set point #70	AV:137	STP# 70-<Set point name>	40370	ADF:138
Set point #71	AV:138	STP# 71-<Set point name>	40371	ADF:139
Set point #72	AV:139	STP# 72-<Set point name>	40372	ADF:140
Set point #73	AV:140	STP# 73-<Set point name>	40373	ADF:141
Set point #74	AV:141	STP# 74-<Set point name>	40374	ADF:142
Set point #75	AV:142	STP# 75-<Set point name>	40375	ADF:143
Set point #76	AV:143	STP# 76-<Set point name>	40376	ADF:144
Set point #77	AV:144	STP# 77-<Set point name>	40377	ADF:145
Set point #78	AV:145	STP# 78-<Set point name>	40378	ADF:146
Set point #79	AV:146	STP# 79-<Set point name>	40379	ADF:147
Set point #80	AV:147	STP# 80-<Set point name>	40380	ADF:148
Set point #81	AV:148	STP# 81-<Set point name>	40381	ADF:149
Set point #82	AV:149	STP# 82-<Set point name>	40382	ADF:150

Magnum	BACnet ID	BACnet Name	Modbus	N2
Set point #83	AV:150	STP# 83-<Set point name>	40383	ADF:151
Set point #84	AV:151	STP# 84-<Set point name>	40384	ADF:152
Set point #85	AV:152	STP# 85-<Set point name>	40385	ADF:153
Set point #86	AV:153	STP# 86-<Set point name>	40386	ADF:154
Set point #87	AV:154	STP# 87-<Set point name>	40387	ADF:155
Set point #88	AV:155	STP# 88-<Set point name>	40388	ADF:156
Set point #89	AV:156	STP# 89-<Set point name>	40389	ADF:157
Set point #90	AV:157	STP# 90-<Set point name>	40390	ADF:158
Set point #91	AV:158	STP# 91-<Set point name>	40391	ADF:159
Set point #92	AV:159	STP# 92-<Set point name>	40392	ADF:160
Set point #93	AV:160	STP# 93-<Set point name>	40393	ADF:161
Set point #94	AV:161	STP# 94-<Set point name>	40394	ADF:162
Set point #95	AV:162	STP# 95-<Set point name>	40395	ADF:163
Set point #96	AV:163	STP# 96-<Set point name>	40396	ADF:164
Set point #97	AV:164	STP# 97-<Set point name>	40397	ADF:165
Set point #98	AV:165	STP# 98-<Set point name>	40398	ADF:166
Set point #99	AV:166	STP# 99-<Set point name>	40399	ADF:167
Set point #100	AV:167	STP# 100-<Set point name>	40400	ADF:168
Set point #101	AV:168	STP# 101-<Set point name>	40401	ADF:169
Set point #102	AV:169	STP# 102-<Set point name>	40402	ADF:170
Set point #103	AV:170	STP# 103-<Set point name>	40403	ADF:171
Set point #104	AV:171	STP# 104-<Set point name>	40404	ADF:172
Set point #105	AV:172	STP# 105-<Set point name>	40405	ADF:173
Set point #106	AV:173	STP# 106-<Set point name>	40406	ADF:174
Set point #107	AV:174	STP# 107-<Set point name>	40407	ADF:175
Set point #108	AV:175	STP# 108-<Set point name>	40408	ADF:176
Set point #109	AV:176	STP# 109-<Set point name>	40409	ADF:177
Set point #110	AV:177	STP# 110-<Set point name>	40410	ADF:178
Set point #111	AV:178	STP# 111-<Set point name>	40411	ADF:179
Set point #112	AV:179	STP# 112-<Set point name>	40412	ADF:180
Set point #113	AV:180	STP# 113-<Set point name>	40413	ADF:181
Set point #114	AV:181	STP# 114-<Set point name>	40414	ADF:182
Set point #115	AV:182	STP# 115-<Set point name>	40415	ADF:183
Set point #116	AV:183	STP# 116-<Set point name>	40416	ADF:184
Set point #117	AV:184	STP# 117-<Set point name>	40417	ADF:185
Set point #118	AV:185	STP# 118-<Set point name>	40418	ADF:186
Set point #119	AV:186	STP# 119-<Set point name>	40419	ADF:187
Set point #120	AV:187	STP# 120-<Set point name>	40420	ADF:188
Set point #121	AV:188	STP# 121-<Set point name>	40421	ADF:189
Set point #122	AV:189	STP# 122-<Set point name>	40422	ADF:190
Set point #123	AV:190	STP# 123-<Set point name>	40423	ADF:191
Set point #124	AV:191	STP# 124-<Set point name>	40424	ADF:192
Set point #125	AV:192	STP# 125-<Set point name>	40425	ADF:193
Set point #126	AV:193	STP# 126-<Set point name>	40426	ADF:194
Set point #127	AV:194	STP# 127-<Set point name>	40427	ADF:195
Set point #128	AV:195	STP# 128-<Set point name>	40428	ADF:196
Set point #129	AV:196	STP# 129-<Set point name>	40429	ADF:197

Magnum	BACnet ID	BACnet Name	Modbus	N2
Set point #130	AV:197	STP# 130-<Set point name>	40430	ADF:198
Set point #131	AV:198	STP# 131-<Set point name>	40431	ADF:199
Set point #132	AV:199	STP# 132-<Set point name>	40432	ADF:200
Set point #133	AV:200	STP# 133-<Set point name>	40433	ADF:201
Set point #134	AV:201	STP# 134-<Set point name>	40434	ADF:202
Set point #135	AV:202	STP# 135-<Set point name>	40435	ADF:203
Set point #136	AV:203	STP# 136-<Set point name>	40436	ADF:204
Set point #137	AV:204	STP# 137-<Set point name>	40437	ADF:205
Set point #138	AV:205	STP# 138-<Set point name>	40438	ADF:206
Set point #139	AV:206	STP# 139-<Set point name>	40439	ADF:207
Set point #140	AV:207	STP# 140-<Set point name>	40440	ADF:208
Set point #141	AV:208	STP# 141-<Set point name>	40441	ADF:209
Set point #142	AV:209	STP# 142-<Set point name>	40442	ADF:210
Set point #143	AV:210	STP# 143-<Set point name>	40443	ADF:211
Set point #144	AV:211	STP# 144-<Set point name>	40444	ADF:212
Set point #145	AV:212	STP# 145-<Set point name>	40445	ADF:213
Set point #146	AV:213	STP# 146-<Set point name>	40446	ADF:214
Set point #147	AV:214	STP# 147-<Set point name>	40447	ADF:215
Set point #148	AV:215	STP# 148-<Set point name>	40448	ADF:216
Set point #149	AV:216	STP# 149-<Set point name>	40449	ADF:217
Set point #150	AV:217	STP# 150-<Set point name>	40450	ADF:218
Set point #151	AV:218	STP# 151-<Set point name>	40451	ADF:219
Set point #152	AV:219	STP# 152-<Set point name>	40452	ADF:220
Set point #153	AV:220	STP# 153-<Set point name>	40453	ADF:221
Set point #154	AV:221	STP# 154-<Set point name>	40454	ADF:222
Set point #155	AV:222	STP# 155-<Set point name>	40455	ADF:223
Set point #156	AV:223	STP# 156-<Set point name>	40456	ADF:224
Set point #157	AV:224	STP# 157-<Set point name>	40457	ADF:225
Set point #158	AV:225	STP# 158-<Set point name>	40458	ADF:226
Set point #159	AV:226	STP# 159-<Set point name>	40459	ADF:227
Set point #160	AV:227	STP# 160-<Set point name>	40460	ADF:228
Set point #161	AV:228	STP# 161-<Set point name>	40461	ADF:229
Set point #162	AV:229	STP# 162-<Set point name>	40462	ADF:230
Set point #163	AV:230	STP# 163-<Set point name>	40463	ADF:231
Set point #164	AV:231	STP# 164-<Set point name>	40464	ADF:232
Set point #165	AV:232	STP# 165-<Set point name>	40465	ADF:233
Set point #166	AV:233	STP# 166-<Set point name>	40466	ADF:234
Set point #167	AV:234	STP# 167-<Set point name>	40467	ADF:235
Set point #168	AV:235	STP# 168-<Set point name>	40468	ADF:236
Set point #169	AV:236	STP# 169-<Set point name>	40469	ADF:237
Set point #170	AV:237	STP# 170-<Set point name>	40470	ADF:238

*- Indicates value multiplied by 10 to include one decimal place. (ie. BMS value of 500 indicates actual value 50.0)

- Set points 4-170 were added to available points in MAGNUM software version 5.01G. For previous versions of MAGNUM software, only set points 1-3 are available.

28.5. Chiller/Circuit States

State values are read-only.

Notable BACnet properties available: Number of States, State-Text (Contains character text of current state)

Magnum	BACnet ID	BACnet Name	Modbus Register	N2
Chiller Unit State	MV:0	CHILLER STATE	30306	BYT:1
Circuit #1 State	MV:1	CIRCUIT #1 STATE	30307	BYT:2
Circuit #2 State	MV:2	CIRCUIT #2 STATE	30308	BYT:3
Circuit #3 State	MV:3	CIRCUIT #3 STATE	30309	BYT:4
Circuit #4 State	MV:4	CIRCUIT #4 STATE	30310	BYT:5
Circuit #5 State	MV:5	CIRCUIT #5 STATE	30311	BYT:6
Circuit #6 State	MV:6	CIRCUIT #6 STATE	30312	BYT:7
Circuit #7 State	MV:7	CIRCUIT #7 STATE	30313	BYT:8
Circuit #8 State	MV:8	CIRCUIT #8 STATE	30314	BYT:9

28.6. Other Points

These points are read-only.

Magnum	BACnet ID	BACnet Name	Modbus	N2
Wanted FLA%	AV:3	Wanted FLA%	30318	ADF:4
Steps Wanted	AV:4	Steps Wanted On	30315	ADF:5
Steps On	AV:5	Steps On	30316	ADF:6
Step Delay	AV:6	Step Delay	30317	ADF:7
Circuit #1 FLA%	AV:7	C1_FL A%	*30319	*ADF:8
Circuit #1 Suction	AV:8	C1_Suction	*30359	*ADF:9
Circuit #1 Disch	AV:9	C1_Discharge	*30367	*ADF:10
Circuit #1 Sat Suction	AV:10	C1_Sat Suct	*30327	*ADF:11
Circuit #1 Sat Disch	AV:11	C1_Sat Disch	*30329	*ADF:12
Circuit #1 Disch SH	AV:12	C1_Disch SH	*30330	*ADF:13
Circuit #1 Suct SH	AV:13	C1_Suct SH	*30328	*ADF:14
Circuit #1 Oil Pres Diff	AV:63	C1_Oil Pres Diff	*30375	*ADF:64
Circuit #2 FLA%	AV:14	C2_FL A%	*30320	*ADF:15
Circuit #2 Suction	AV:15	C2_Suction	*30360	*ADF:16
Circuit #2 Disch	AV:16	C2_Discharge	*30368	*ADF:17
Circuit #2 Sat Suction	AV:17	C2_Sat Suct	*30331	*ADF:18
Circuit #2 Sat Disch	AV:18	C2_Sat Disch	*30333	*ADF:19
Circuit #2 Disch SH	AV:19	C2_Disch SH	*30334	*ADF:20
Circuit #2 Suct SH	AV:20	C2_Suct SH	*30332	*ADF:21
Circuit #2 Oil Pres Diff	AV:64	C2_Oil Pres Diff	*30376	*ADF:65
Circuit #3 FLA%	AV:21	C3_FL A%	*30321	*ADF:22
Circuit #3 Suction	AV:22	C3_Suction	*30361	*ADF:23
Circuit #3 Disch	AV:23	C3_Discharge	*30369	*ADF:24
Circuit #3 Sat Suction	AV:24	C3_Sat Suct	*30335	*ADF:25

Magnum	BACnet ID	BACnet Name	Modbus	N2
Circuit #3 Sat Disch	AV:25	C3_Sat Disch	*30337	*ADF:26
Circuit #3 Disch SH	AV:26	C3_Disch SH	*30338	*ADF:27
Circuit #3 Suct SH	AV:27	C3_Suct SH	*30336	*ADF:28
Circuit #3 Oil Pres Diff	AV:65	C3_Oil Pres Diff	*30377	*ADF:66
Circuit #4 FLA%	AV:28	C4_FLA%	*30322	*ADF:29
Circuit #4 Suction	AV:29	C4_Suction	*30362	*ADF:30
Circuit #4 Disch	AV:30	C4_Discharge	*30370	*ADF:31
Circuit #4 Sat Suction	AV:31	C4_Sat Suct	*30339	*ADF:32
Circuit #4 Sat Disch	AV:32	C4_Sat Disch	*30341	*ADF:33
Circuit #4 Disch SH	AV:33	C4_Disch SH	*30342	*ADF:34
Circuit #4 Suct SH	AV:34	C4_Suct SH	*30340	*ADF:35
Circuit #4 Oil Pres Diff	AV:66	C4_Oil Pres Diff	*30378	*ADF:67
Circuit #5 FLA%	AV:35	C5_FLA%	*30323	*ADF:36
Circuit #5 Suction	AV:36	C5_Suction	*30363	*ADF:37
Circuit #5 Disch	AV:37	C5_Discharge	*30371	*ADF:38
Circuit #5 Sat Suction	AV:38	C5_Sat Suct	*30343	*ADF:39
Circuit #5 Sat Disch	AV:39	C5_Sat Disch	*30345	*ADF:40
Circuit #5 Disch SH	AV:40	C5_Disch SH	*30346	*ADF:41
Circuit #5 Suct SH	AV:41	C5_Suct SH	*30344	*ADF:42
Circuit #5 Oil Pres Diff	AV:67	C5_Oil Pres Diff	*30379	*ADF:68
Circuit #6 FLA%	AV:42	C6_FLA%	*30324	*ADF:43
Circuit #6 Suction	AV:43	C6_Suction	*30364	*ADF:44
Circuit #6 Disch	AV:44	C6_Discharge	*30372	*ADF:45
Circuit #6 Sat Suction	AV:45	C6_Sat Suct	*30347	*ADF:46
Circuit #6 Sat Disch	AV:46	C6_Sat Disch	*30349	*ADF:47
Circuit #6 Disch SH	AV:47	C6_Disch SH	*30350	*ADF:48
Circuit #6 Suct SH	AV:48	C6_Suct SH	*30348	*ADF:49
Circuit #6 Oil Pres Diff	AV:68	C6_Oil Pres Diff	*30380	*ADF:69
Circuit #7 FLA%	AV:49	C7_FLA%	*30325	*ADF:50
Circuit #7 Suction	AV:50	C7_Suction	*30365	*ADF:51
Circuit #7 Disch	AV:51	C7_Discharge	*30373	*ADF:52
Circuit #7 Sat Suction	AV:52	C7_Sat Suct	*30351	*ADF:53
Circuit #7 Sat Disch	AV:53	C7_Sat Disch	*30353	*ADF:54
Circuit #7 Disch SH	AV:54	C7_Disch SH	*30354	*ADF:55
Circuit #7 Suct SH	AV:55	C7_Suct SH	*30352	*ADF:56
Circuit #7 Oil Pres Diff	AV:69	C7_Oil Pres Diff	*30381	*ADF:70
Circuit #8 FLA%	AV:56	C8_FLA%	*30326	*ADF:57
Circuit #8 Suction	AV:57	C8_Suction	*30366	*ADF:58
Circuit #8 Disch	AV:58	C8_Discharge	*30374	*ADF:59
Circuit #8 Sat Suction	AV:59	C8_Sat Suct	*30355	*ADF:60
Circuit #8 Sat Disch	AV:60	C8_Sat Disch	*30357	*ADF:61
Circuit #8 Disch SH	AV:61	C8_Disch SH	*30358	*ADF:62
Circuit #8 Suct SH	AV:62	C8_Suct SH	*30356	*ADF:63
Circuit #8 Oil Pres Diff	AV:70	C8_Oil Pres Diff	*30382	*ADF:71

*- Indicates value multiplied by 10 to include one decimal place. (ie. BMS value of 500 indicates actual value 50.0)

28.7. Network inputs to MCS-Magnum

The MCS-MAGNUM can receive changes from the network to enable or disable the Network Run/Stop, Network Target Reset (adjustments to the Cooling Target, Set point #1, based on Set point #21), Network Demand FLA, and Network Demand Steps.

The MCS-Magnum must be setup to accept these inputs. The configuration file must contain a Network Run/Stop, Network Target, Network Demand FLA, and Network Demand Steps sensors.

Note: If these sensors are not setup properly, changes will not be accepted by the MCS-Magnum.

Magnum	BACnet ID	BACnet Name	Modbus	N2
Network Run/Stop	AV:246	Net_R/S	40201	BO:247
Network Target/Reset	AV:247	Net_Tar/Res	40202	AO:248
Network Demand/FLA	AV:248	Net_Demad_FLA	40204	AO:249
Network Demand/Steps	AV:249	Net_Demad_Steps	40205	AO:250

The MCS-MAGNUM must be setup to accept these inputs. The configuration file in the MCS-MAGNUM must contain a Network Run/Stop, and /or Network Target Reset, and/or Network Demand FLA, and/or Network Demand Steps sensors. Note the following Information Screen has a Network Run/Stop, and /or Network Target Reset sensors inputs indicated. This is an example of how the MCS-Config program must be setup.

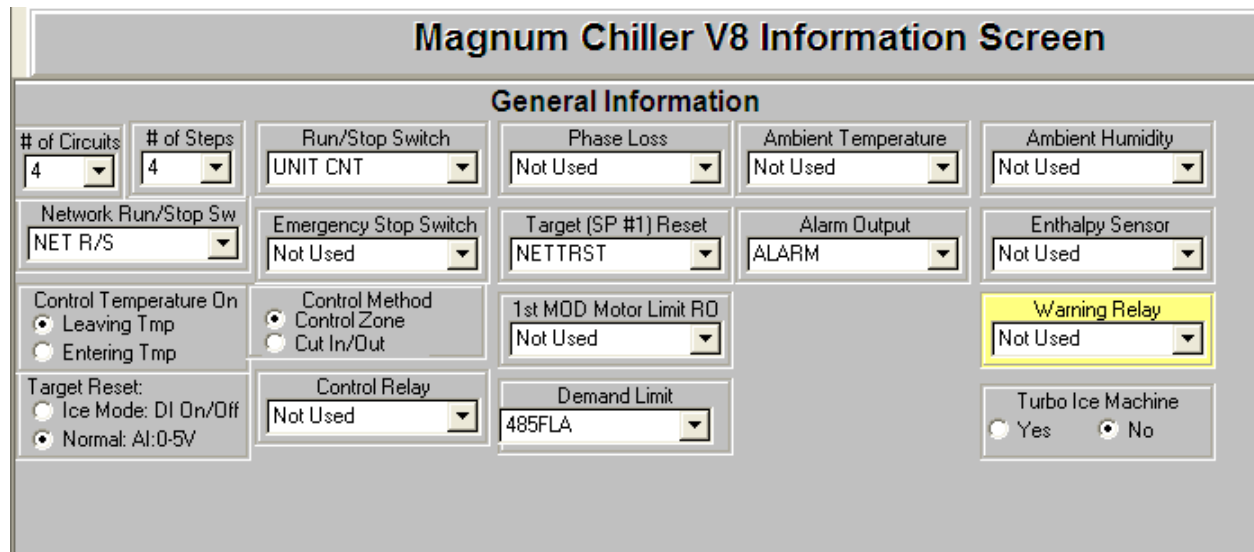

The sensors must be set up as follows (This is only an example)

If these sensors are not setup properly, changes will not be accepted by the MCS-MAGNUM

1-1	NET R/S	485 RUN	0	0	Not Used	Not Used	Not Used	Auto
1-2	NETTRST	485 CW RSET	0	0	Not Used	Not Used	Not Used	Auto
1-3	485FLA	485 Dmd FLA%	0	0	Not Used	Not Used	Not Used	Auto
1-4	485Steps	485 Dmd Step	0	0	Not Used	Not Used	Not Used	Auto

28.8. MCS Capacity Control State Chart

The values exposed in the capacity state relate to the descriptions in this table.

State Number	Description
0	"UNIT IN POWER UP"
1	"RUN NOT ALLOWED "
2	"NO RUN- I/O LOST"
3	"UNIT IN LOCKOUT "
4	"UNIT IS OFF "
5	"UNIT IS HOLDING "
6	"UNIT UNLOADING "
7	"UNIT IS LOADING "
8	"NO RUN - SAFETY "
9	"RUN/STOP SW OFF "
10	"SCHEDULED OFF "
11	"OFF-NO EVAP FLOW"
12	"OFF-NO COND FLOW"
13	"AMBIENT OFF "
14	"PROCESS HEAT OFF"
15	"UNIT IS UNLOADED"
16	"UNIT IS LOADED "
17	"OFF TMP-ICE MADE "
18	"ECONOMIZER ONLY "
19	"SWITCHING MODES "
20	"UNIT SMOKE UNLDG"
21	"UNIT OFF UNLDING"
22	"UNIT DMD UNLDING"
23	"UNIT HEAT UNLDNG"

28.9. MCS Compressor Control State Chart

The values exposed in the compressor state relate to the descriptions in this table.

State Number	Description
0	"LOST IO LOCKED"
1	"CMP LOCKED OUT"
2	"SWITCHED OFF "
3	"CMP PUMP DOWN "
4	"CMP ANTICYCLE "
5	"CMP OFF/READY "
6	"OIL PMP LUBING"
7	"CMP IS RUNNING"
8	"CMP UNLOADED "
9	"UNLD1/HGBP OFF"
10	"PART LOADED "
11	"CMP IS HOLDING"
12	"CMP IS LOADING"
13	"CMP IS UNLDING"
14	"CMP IS AT 100%"
15	"FAST UNLOADING"
16	"LO SUCT UNLOAD"
17	"LO SUCT HOLD "

State Number	Description
18	"HI DISC UNLOAD"
19	"HI DISC HOLD "
20	"SAFETY TRIPPED"
21	"LO TEMP UNLOAD"
22	"LO TEMP HOLD "
23	"HI AMP HOLD "
24	"HI DIS TMP HLD"
25	"CMP IS AT 40% "
26	"CMP IS AT 70% "
27	"HI WATER HOLD "
28	"EXTRA 70% STEP "
29	"OFF-LO OIL TMP "
30	"HI AMP UNLDING "
31	"DEF PREPMP OUT "
32	"DEFROSTING "
33	"DEF PUMP DOWN "
34	"HI TEMP UNLOAD "
35	"HI TEMP HOLD "

29. MCS-MAGNUM BMS CONNECTIONS

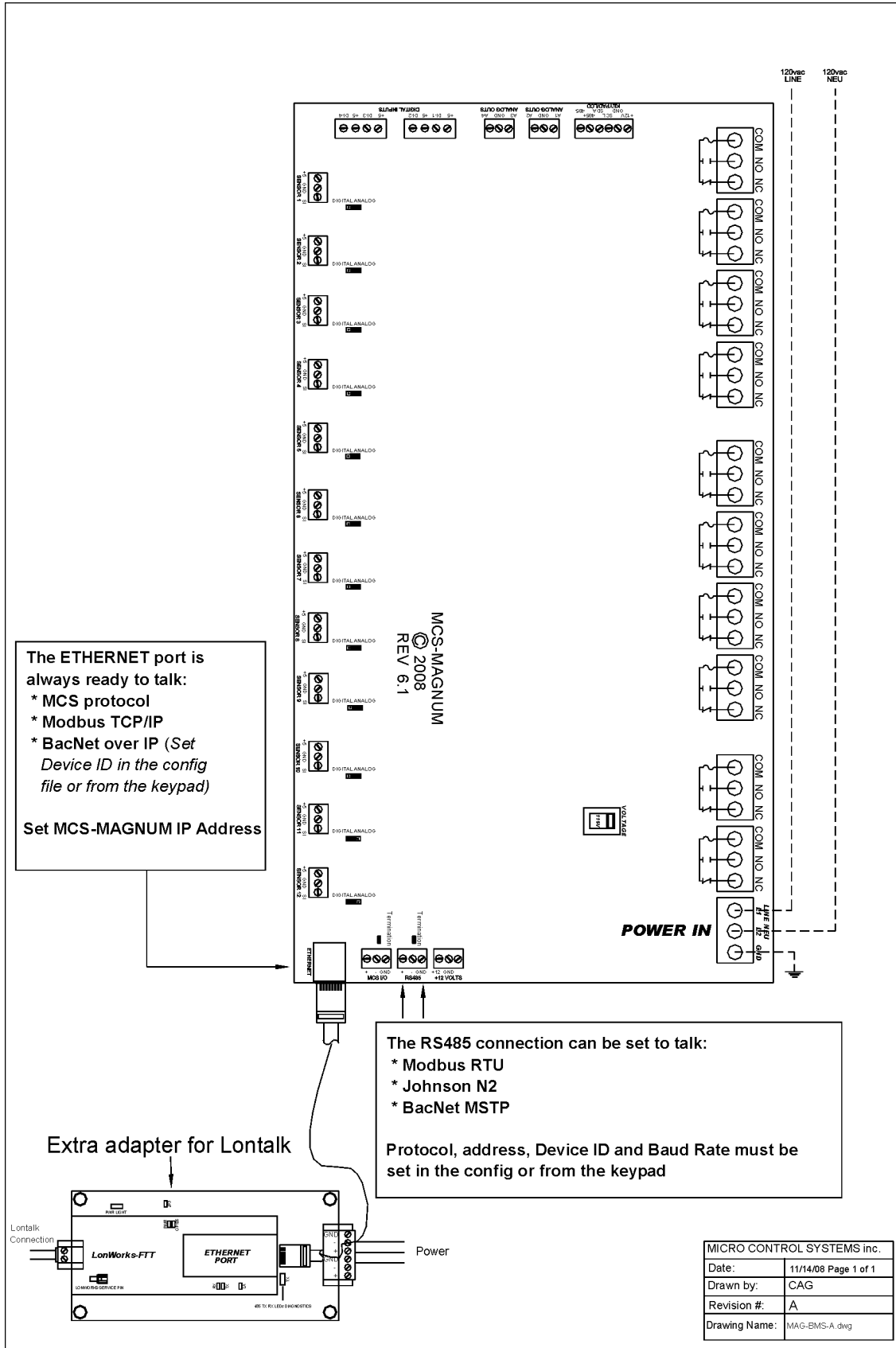

29.1. MCS-Magnum BMS protocols settings.

29.1.1. Bacnet MSTP:

The Bacnet MS/TP DEVICE ID is a five-digit number. The first three digits are based on our Bacnet vendor ID that is 181, and the last two are set by the Bacnet/MSTP address.

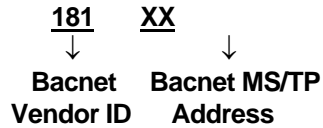

The Bacnet address can be verified and changed (with the proper authorization code) from the keypad/LCD of a live unit.

To get authorized on Magnum do the following:

- Press 'Menu'
- Using ↑, ↓, →, or ← position cursor to 'Passwords'
- Press ↵ key.
- Enter 4 digit password & press ↵.
- Press 'Menu' to make next selection.

The following steps will display the Bacnet MSTP Network address, and the Baud Rate:

(To change the address and the Baud Rate you must be authorized)

- Press the MENU key and then Using ↑, ↓, →, or ← position cursor to Serv Tools then press the ENTER key.
- Select RS485 Network then press Enter.
- Select Protocol then press Enter. Change the protocol to BACnet MSTP
- Select address then press Enter. Change the address so it matches the last two digits of the device ID then press Enter.
- Select Baud then press Enter. Set the baud rate then press Enter.
- Connect the communication wires to the TX RS485 three-position terminal located above the Ethernet connector.

29.1.2. Bacnet Over IP:

The BACNET DEVICE ID is a five-digit number. The first three digits are based on our Bacnet vendor ID that is 181, and the last two are set by the Bacnet/MSTP address.

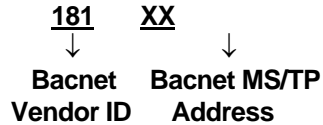

The Bacnet address can be verified and changed (with the proper authorization code) from the keypad/LCD of a live unit.

To get authorized on Magnum do the following:

- Press 'Menu'
- Using ↑, ↓, →, or ← position cursor to 'Passwords'
- Press ↵ key.
- Enter 4 digit password & press ↵.
- Press 'Menu' to make next selection.

The following steps will display the Bacnet MSTP Network address, and the Baud Rate:

(To change the address and the Baud Rate you must be authorized)

- Press the MENU key and then Using ↑, ↓, →, or ← position cursor to Serv Tools then press the ENTER key.
- Select RS485 Network then press Enter.
- Select Protocol then press Enter. Change the protocol to BACnet MSTP
- Select address then press Enter. Change the address so it matches the last two digits of the device ID then press Enter.
- Select Protocol then press Enter. Set the protocol back to MCS.

The following steps will display the Ethernet Network settings:

(To change the settings you first must be authorized)

If you are going to manually assign the IP Address, Subnet Mask, and Default Gateway.

- Press the MENU key and then Using ↑, ↓, →, or ← position cursor to Serv Tools then press the ENTER key.
- Select Ethernet Network then press Enter.
- Set "DHCP Enabled" to **NO**.
- Set the "IP Address".
- Set the "Subnet Mask".
- Set "Default Gateway".

If you are going to let your network assign the IP Address, Subnet Mask, and Default Gateway.

- Press the MENU key and then Using ↑, ↓, →, or ← position cursor to Serv Tools then press the ENTER key.
- Select Ethernet Network then press Enter.
- Set "DHCP Enabled" to **YES**; Connect the MCS-Magnum to the network and cycle power to the board.

29.1.3. Modbus RTU:

The Modbus RTU address can be verified and changed (with the proper authorization code) from the keypad/LCD of a live unit.

To get authorized on Magnum do the following:

- Press 'Menu'
- Using ↑, ↓, →, or ← position cursor to 'Passwords'
- Press ↵ key.
- Enter 4 digit password & press ↵.
- Press 'Menu' to make next selection.

The following steps will display the Modbus RTU Network address, and the Baud Rate:

(To change the address and the Baud Rate you must be authorized)

- Press the MENU key and then Using ↑, ↓, →, or ← position cursor to Serv Tools then press the ENTER key.
- Select RS485 Network then press Enter.
- Select Protocol then press Enter. Change the protocol to Modbus.
- Select address then press Enter. Change the address then press Enter.
- Select Baud then press Enter. Set the baud rate then press Enter.
- Connect the communication wires to the TX RS485 three-position terminal located above the Ethernet connector.

29.1.4. Modbus TCP/IP:

This protocol is always active.

Make sure the MCS-Magnum network settings are set correctly.

The following steps will display the Ethernet Network settings:
(To change the settings you first must be authorized)

To get authorized on Magnum do the following:

- Press 'Menu'
- Using ↑, ↓, →, or ← position cursor to 'Passwords'
- Press ↵ key.
- Enter 4 digit password & press ↵.
- Press 'Menu' to make next selection.

If you are going to manually assign the IP Address, Subnet Mask, and Default Gateway.

- Press the MENU key and then Using ↑, ↓, →, or ← position cursor to Serv Tools then press the ENTER key.
- Select Ethernet Network then press Enter.
- Set "DHCP Enabled" to **NO**.
- Set the "IP Address".
- Set the "Subnet Mask".
- Set "Default Gateway".

If you are going to let your network assign the IP Address, Subnet Mask, and Default Gateway.

- Press the MENU key and then Using ↑, ↓, →, or ← position cursor to Serv Tools then press the ENTER key.
- Select Ethernet Network then press Enter.
- Set "DHCP Enabled" to **YES**; Connect the MCS-Magnum to the network and cycle power to the board.

29.1.5. Johnson N2:

The N2 address can be verified and changed (with the proper authorization code) from the keypad/LCD of a live unit.

To get authorized on Magnum do the following:

- Press 'Menu'
- Using ↑, ↓, →, or ← position cursor to 'Passwords'
- Press ↵ key.
- Enter 4 digit password & press ↵.
- Press 'Menu' to make next selection.

The following steps will display the N2 Network address, and the Baud Rate:

(To change the address and the Baud Rate you must be authorized)

- Press the MENU key and then Using ↑, ↓, →, or ← position cursor to Serv Tools then press the ENTER key.
- Select RS485 Network then press Enter.
- Select Protocol then press Enter. Change the protocol to N2.
- Select address then press Enter. Change the address then press Enter.
- Select Baud then press Enter. Set the baud rate then press Enter.
- Connect the communication wires to the TX RS485 three-position terminal located above the Ethernet connector.

30. User Logic

MAGNUM provides the user the ability to customize control logic and calculated values. This logic is available by configuring a sensor input, relay output, or analog output when it is defined as a user logic type. The sensor input type for user logic is USER VAL. User Logic may be adjusted at run time via MCS-Connect, however adjustments require a factory authorization.

30.1. Operands

Operands are the building blocks of the MAGNUM User Logic. User logic uses Operands to configure which point in the MAGNUM controller is to be used for control and calculation. Operands allow the user to reference an input value, output value, calculated chiller control value, calculated circuit control value, or enter a fixed value with one decimal place (-3276.8 to 3276.7). These operands are then used to calculate USER VAL sensors, control relay outputs, and control analog outputs.

A relay outputs value is 0 if it is off and a 1 if it is on.

A digital inputs value is 0 if it is off and a 1 if it is on.

An analog input and analog output value are the actual values as displayed, includes the decimal place.

The unit, circuit or loop state is a numeric value that will relate to the state names in this manual.

30.2. User Sensor Input (USER VAL)

The user logic sensor value is a calculated value instead of a hardwired external sensor. The USER VAL sensor can add, subtract, multiply, divide, use highest value, or use lowest value of 2 operand values. The window below from MCS-Config is configuring a USER VAL.

30.3. User Relay Output

User Relay Outputs allow customized control of relays based on operand values. The User Relay Output can calculate a value derived from two operands and combine the calculated value with a greater than and less than conditions to turn a relay on/off. The User relay is capable of delaying the relay ON condition before turning the relay ON.

The screenshot shows a configuration window titled "UserDefined_RO" with a sub-title "FrzAlarm".

- Operand #1:** Type is "SI", and the value is "FREEZE".
- Operand #2:** Type is "Fixed Value", and the value is "0".
- Limit #1:** Type is "Fixed Value", value is "0", and the state is "OFF".
- Limit #2:** Type is "Fixed Value", value is "1", and the state is "ON".
- Delay before ON:** Set to "5". Description: "Must satisfy for this number of seconds before turning On or Pulsing (0 - 32,726)".
- Pulse Count:** Set to "0". Description: "This is the time to Pulse the Relay in 100ms increments (0 - 255)".
- Pulse Delay:** Set to "0". Description: "Seconds between Pulses (0 - 255)".
- Store Alarm Msg when Relay turns On?:** Radio buttons for "YES" (selected) and "NO".
- Turn on General Alarm Relay:** Radio buttons for "YES" and "NO" (selected).

Buttons at the bottom include "Apply", "OK", and "Cancel".

In the above example the "Store Alarm Msg " option has been selected. When this relay goes from an off to an on state an alarm message will be generated with the name of this relay. This example will not turn on the general alarm relay. If yes to this option the general alarm relay would have been turned on when the message was generated.

30.4. User Analog Output

Linear control for analog output allows the user to control an analog value based on feedback from a sensor input or other operand control input value. The output can be set to control only when a relay is ON and fixed at a given output when the relay is OFF. Also, control requiring a relay ON can be disabled and linear control allowed at all times. Linear Control will monitor the Control Input and adjust the analog output based the minimum/maximum output values. The Linear Control window below is an example of Linear Control settings using MCS-Connect. Linear Control settings are adjustable via MCS-Connect at run time with FACTORY level authorization.

MY ANLOG

Control Input

SI ▼
SUCT PSI ▼

Control Requires Relay-ON COMP 1 ▼

Output when Relay-OFF (0% to 100%)

Min Output (0% to 100%)	25.0%	50.0%	75.0%	Max Output (0% to 100%)
<input style="width: 60px;" type="text" value="0"/>	←----- ----- ----- ----->			<input style="width: 60px;" type="text" value="100"/>
Input for Min Output (-3276.8 to 3276.7)	28.5	28.0	27.5	Input for Max Output (-3276.8 to 3276.7)
<input style="width: 60px;" type="text" value="29.0"/>	←----- ----- ----- ----->			<input style="width: 60px;" type="text" value="27.0"/>

OK
Cancel

--- NOTE ---

- 1) **SENSOR INPUTS SHOULD BE SHIELDED CABLE WITH SHIELD TIED TO GROUND ON MAGNUM SENSOR INPUT GROUND TERMINAL.**

- 2) **THE FOUR DIGITAL INPUTS, ON THE MAGNUM PRINTED CIRCUIT BOARD, DO NOT REQUIRE SHIELDED CABLE.**

- 3) **ALL MCS BOARDS WITH 24/120/240 VAC MUST HAVE GROUNDS WIRED FROM TERMINAL DIRECTLY TO GROUND. (DO NOT JUMPER GROUNDS).**